



IRT[®]
SYSTEM
Hyperion

Superior Curing Technology





- *Practical design*
- *Short curing times*
- *Large curing area*
- *Even heat distribution*
- *Gold-coated FreeForm reflectors*
- *Reduced energy consumption*
- *Environmentally friendly*



IR & UVA Curing

Advanced technology

IRT Hyperion offers a wide selection of Short-wave Infrared (IR) and ultraviolet (UVA) mobile dryers and each model has its own particular area of use. IRT Hyperion products are user-friendly and are really easy to move around in the workshop.

Every part in a Hyperion dryer is based on a well thought-out and tested design based on user-friendliness and capacity.

The smart foot design even allows it to get under low cars and it is possible to place the mobile dryer around a wheel.

Another example of the well thought-out design is the stand arm on the large models. It has acquired the characteristic Hyperion angle in order for the cassettes to reach above the roof of high vehicles or an SUV and still stand steady and stable on the floor.

Moving an IRT Hyperion mobile around the workshop is really easy thanks to its low centre of gravity. It is easy to aim the cassettes at the surface to be cured as the arm is well-levelled and balanced.

The market's most effective reflectors

We are the only company having gold-coated reflectors behind the short-wave lamps. For this reason, our IR dryers have unsurpassed drying capacity.

The Hyperion FreeForm reflectors provide a more even heat distribution and a larger curing area than conventional reflectors, while they feature reduced power

consumption. In turn, this increases productivity and raises the quality of the result of drying.

Environmentally friendly

Our mobile dryers irradiate the object and do not heat the surrounding air thereby minimizing energy losses. This provides an efficient use of energy and shortens drying times, which is good for the environment.

Time to cure paint

With 12 pre-set and 3 custom programs, you can handle all paint materials on the market. Thanks to the easily understandable and self-instructional menus, program selection is quick and easy. If you want, you can go one step further and create your own program settings. You will continuously be able to follow the curing process on the control unit display.

Start the control unit, select a program – then dry.

This is as difficult as it gets with advanced and user friendly technology.

IRT PcAuto & PcD

Easy curing with process control

FreeForm reflectors

With the introduction of the new, gold-coated, asymmetric FreeForm reflectors, we have developed the reflectors of the future. Increased heat distribution provides a more even heat distribution implying that a larger area can be cured during the same period.

A lot of energy is saved by only irradiating the object and not heating up the surrounding air. All cables from the stand to the cassettes are enclosed. You avoid loose cables that can be burned or cause scratches in the paint, leaving your hands free to move the dryer.

Cassette/lamps

There are two things that shorten the service life of an IR lamp: overheating and dust. An IRT lamp should last for 20,000 operating hours. For this reason, the Hyperion cassettes are equipped with powerful ventilation cooling both lamps and cassettes. This extends the life of the lamps significantly. The problems with dust have been resolved with a new, effective particle filter on the rear of the cassette. The software informs the operator of how much cleaning capacity is left in the particle filter and when it is time for the next filter replacement.

Stand

Thanks to the special angle of the arm and the advanced design of the foot, curing is possible in places that were previously inaccessible.

IRT Hyperion reaches higher than any other mobile dryer, 2,250 mm with the cassette in the horizontal position and approx. 2,550 mm in the vertical position.

The foot design even allows it to get under low cars and it is possible to place the mobile dryer around a wheel.

The mobile unit's large and well-balanced wheels roll unhindered of floor gratings and easily cope with air hoses and other obstacles on the workshop floor.

Control unit

The most advanced Hyperion models are equipped with advanced technology such as a temperature measurement, laser circle and digital distance sensor. 18 different languages can easily be set.

The laser circle shows where the measurement of the temperature on the curing area takes place, and the ultrasound sensor measures the distance and signals when the distance is correct.

The temperature is continuously measured, while the microprocessor regulates the effective output upwards or downwards in a split second for optimal curing results.

As an operator, you can continuously monitor the curing process and receive information about such things as object temperature and elapsed/remaining program time.

Start the control unit, select a program – then dry.



Easy to understand – easy to use



IRT PrepCure

Even the smallest models are very efficient

The smaller Hyperion models have the same high quality as the advanced IRT dryers, but are somewhat simpler as regards function and design.

Common characteristics for all Hyperion dryers:

- Short-wave lamps
- Gold-coated FreeForm reflectors
- Powerful ventilation
- Increased heat propagation
- Even heat distribution
- Large drying areas

IRT 3 PrepCure and IRT 4 PrepCure

are ideal for use in the prep station. Both are equipped with a compact cassette that is controlled by two digital timers – Flash off up to 30 minutes, Full bake up to 30 minutes. The cassette is balanced with a gasfilled damper and can easily be operated with one hand. With IRT 4 PrepCure, you can reach a height of 2,150 mm, enabling curing of car roofs on high cars.

IRT 1 PrepCure and IRT 2 PrepCure

are excellent aids for body shops. They can be used to heat small areas or for quick drying of putty, filler and clear coat as well as for applying and removing stickers.

IRT 1 and IRT 2 can either be used as hand-held dryers or be mounted on stands. By holding the dryer in your hand you can cure areas that are difficult to reach. The On/Off button is integrated in the stable handle.

The stand has a timer that can be set to a maximum of 120 minutes. A holder on the stand allows for both vertical and horizontal drying.



IRT PcAuto & PcD



IRT 4-1 PcAuto & IRT 4-2 PcAuto

These are our most complete mobile dryers with the highest output and capacity. The products are easy to use and the curing times are reduced to a minimum.

- One (6 kW) or two (12 kW) cassettes depending on desired drying surface
- Unique possibilities to position the cassettes
- Gold-coated FreeForm reflectors for optimal heat distribution
- Computerised monitoring of curing
- Pyrometer for exact temperature control
- Laser circle indicates where temperature measuring takes place
- Electronic distance sensor
- 12 pre-set and 3 custom programs
- Can cure all paint materials
- Smart stand design
- Efficient particle filter on the cassettes
- Powerful ventilation that cools the cassette and increases lamp life
- Also available as a Rail Dryer for IRT Rail Systems
- Maximum cassette height 2,250 mm (horizontal), 2,550 mm (vertical)



IRT 3-1 PcD & IRT 3-2 PcD

These are the standard dryers for all types of workshops. They are mostly used for small to medium-sized repairs and for primers, but have sufficient output to cure all kinds of paint materials.

- One (3 kW) or two (6 kW) cassettes depending on desired drying surface
- Unique possibilities to position the cassettes
- Gold-coated FreeForm reflectors for optimal heat distribution
- Computerised curing process
- Electronic distance sensor
- 12 pre-set and 3 custom programs
- Can cure all paint materials
- Smart stand design
- Efficient particle filter on the cassettes
- Powerful ventilation that cools the cassette and increases lamp life
- Also available as a Rail Dryer for IRT Rail Systems
- Maximum cassette height 2,250 mm (horizontal), 2,550 mm (vertical)

TECHNICAL DATA

	4-1 PcAuto		4-2 PcAuto		3-1 PcD		3-2 PcD	
Voltage	220-240V 3Ph/PE	380-420V 3Ph/PE	220-240V 3Ph/PE	380-420V 3Ph/PE	220-240V 3Ph/PE	380-420V 3Ph/PE	220-240V 3Ph/PE	380-420V 3Ph/PE
Frequency	50-60 Hz	50-60 Hz	50-60 Hz	50-60 Hz	50-60 Hz	50-60 Hz	50-60 Hz	50-60 Hz
Current	15 A	9 A	30 A	16 A	8 A	5 A	15 A	9 A
Output power	6 kW	6 kW	12 kW	12 kW	3 kW	3 kW	6 kW	6 kW
Fuse	16 A	16 A	32 A	16 A	16 A	16 A	16 A	16 A

IRT PrepCure



IRT 3 PrepCure & IRT 4 PrepCure

These dryers are ideal for curing small to medium-sized surfaces. The products are used to speed up drying of putty, filler, base and clear coat. Using two digital timers, the products are very easy to use.

- 3 kW cassette
- Unique possibilities for positioning the cassettes
- Gold-coated FreeForm reflectors for optimal heat distribution
- Two digital timers:
 - Flash-off 50% output power
 - Full bake 100% output power
- The timer's settings will remain after power off
- Easy to set and read the drying times
- Can cure all paint materials
- Efficient particle filter on the cassettes
- Powerful ventilation that cools the cassette and increases lamp life
- Maximum cassette height (IRT 3) 1,300 mm horizontal
- Maximum cassette height (IRT 4) 2,150 mm horizontal



IRT 1 PrepCure & IRT 2 PrepCure

These dryers are suitable for minor paint and panel work, and can be used as hand-held units. They are recommended for surfaces that otherwise are difficult to access. Both dryers can also be mounted on a stand equipped with a timer.

- One lamp of 1 kW (IRT 1)
- Two lamps with a total of 2 kW (IRT 2)
- Gold-coated reflectors for optimal heat distribution
- FreeForm reflectors (IRT 2 only)
- Manual timer on the stand (120 minutes)
- Flexible and easy use
- Can cure all base materials and paint materials
- Powerful ventilation that cools the cassette and increases lamp life (IRT 2)
- On/Off button integrated in handle
- Stand height 1,450 mm

TECHNICAL DATA

	IRT 3 PrepCure	IRT 4 PrepCure	IRT 1 PrepCure	IRT 2 PrepCure
Voltage	220-240V 1Ph/PE	220-240V 1Ph/PE	220-240V 1Ph/PE	220-240V 1Ph/PE
Frequency	50-60 Hz	50-60 Hz	50-60 Hz	50-60 Hz
Current	13 A	13 A	4 A	8 A
Output power	3 kW	3 kW	1 kW	2 kW
Fuse	16 A (UK 13 A, NA 20 A)	16 A (UK 13 A, NA 20 A)	10 A	10 A



IRT UVA

Curing of UV paint material

Our easily maneuverable UVA (ultraviolet) products are equipped with one or two compact high efficiency 1000 W UVA-lamps which make the curing extremely fast.

We also offer a product with a combination of infrared and UV lamps. The IR and the UV part can both be run individually or can be run in combination with each other. There are all possibilities to program this model in different configurations.

The design, combined with a gas spring, makes cassette adjustment simpler. The control unit enables individual control of each cassette. The time can be set for each cassette 0-30 minutes.

UV curing

The ultraviolet light spectrum generated by a UV-lamp interacts with special coating chemistries to produce a high-quality, durable curing.

Most importantly to achieve a good and fast curing result there must be enough UV-A intensity. Our UVA products have an outstanding intensity to achieve the best curing result.

The user must cover all naked skin and use UV-protection goggles.

CURING SURFACES

IRT COMBI 4-1 IR-UVA 1

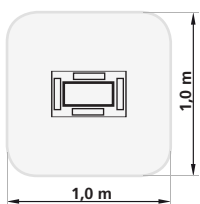

One cassette at a distance of 55 cm with an UV-A intensity of 25mW/cm².

IRT UVA 1 PrepCure 4

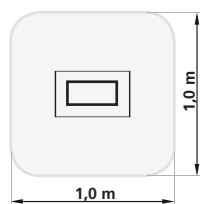

One cassette at a distance of 55 cm with an UV-A intensity of 25mW/cm².

IRT UVA 2 PrepCure 4

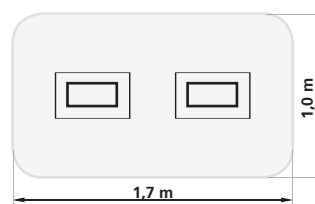

Two cassettes at a distance of 55 cm with an UV-A intensity of 25mW/cm².

IRT UVA 1 PrepCure 3

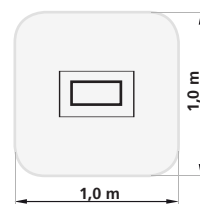

One cassette at a distance of 55 cm with an UV-A intensity of 25mW/cm².



IRT COMBI 4-1 IR-UVA 1

The combination of infrared and UV makes this mobile dryer unique. The mobile dryer can be used for curing/drying of standard 2k products, putty, filler, top and clear coat. Flash off of waterborne basecoats, curing of waterborne clear coats. Curing of UV putty, filler and clear coats, both 1k and 2k UV material.

- One cassette with 4 IR lamps and 1 UV lamp
- The IR and the UV part can be run;
 - individually
 - in combination with each other
- The control unit includes programme selection
- Also available as a Rail Dryer for IRT Rail Systems
- Maximum cassette height 2,240 mm



IRT UVA 1 & UVA 2 PrepCure 4

A mobile UV dryer is an essential aid when curing UV paint material on small and medium sized areas. The IRT UVA dryer works with UVA, starting with a wavelength of 320 nm.

- One (UVA 1) or two (UVA 2) cassettes
- Each cassette is equipped with one-UV lamp and a special designed reflector for optimal reflection and superior distribution on the curing area
- The curing time is regulated with an electronic timer
- Also available as a Rail Dryer for IRT Rail Systems
- Maximum cassette height 2,240 mm



IRT UVA 1 PrepCure 3

A mobile UV dryer is an essential aid when curing UV paint material on small and medium sized areas. The IRT UVA dryer works with UVA, starting with a wavelength of 320 nm.

- One cassette
- Curing of UV paint on vertical surfaces
- The cassette is equipped with one UV-lamp and a special designed reflector for optimal reflection and superior distribution on the curing area
- The curing time is regulated with an electronic timer
- Maximum cassette height 1,310 mm

TECHNICAL DATA

	IRT COMBI 4-1 IR-UVA 1	IRT UVA 1 PrepCure 4	IRT UVA 2 PrepCure 4	IRT UVA 1 PrepCure 3
Voltage	400V 3Ph ~/PE	230V 1Ph ~/PE	230V 1Ph ~/PE	230V 1Ph ~/PE
Frequency	50 Hz	50 Hz	50 Hz	50 Hz
Power	6 kW IR 1 kW UV-A	1 kW UV-A	2 kW UV-A	1 kW UV-A
Fuse	10 A	10 A	10 A	10 A
Weight	~ 70 kg	~ 55 kg	~ 60 kg	~ 23 kg

IRT Systems

Fixed installations – IRT Arches & Rails

We offer fixed installations in the preparation bays and in the curing booth.



IRT Customized solutions

We also offer customized heating solutions that are tailored to different applications or special requests.

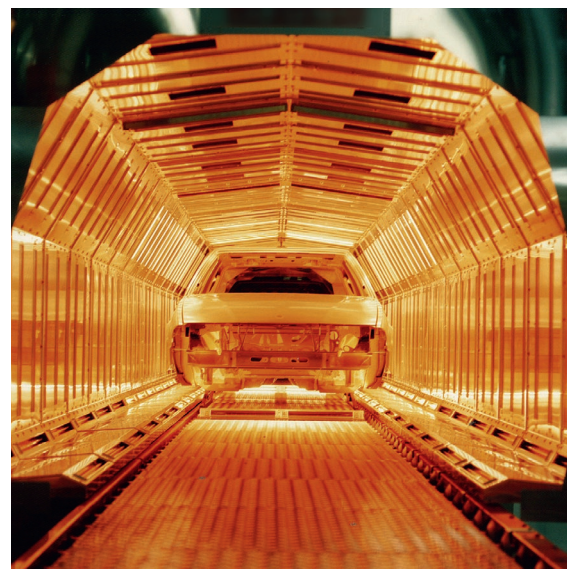

Technical data

Short-wave for most efficient curing

All IRT dryers use short-wave technology. This, together with the unique IRT FreeForm reflectors, provides the best heat transfer possible. Short-wave IR has several other advantages. It is easy to control, provides full heat immediately and penetrates deep into the paint. The paint cures from the inside and out without retaining solvents and moisture that gives rise to problems with quality. Heat losses to the air are minimal and all energy is transferred to the surface to be dried.

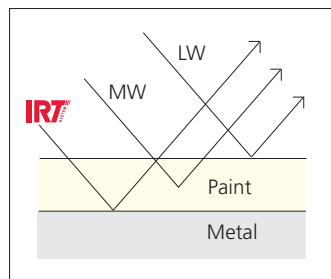

Simplified diagram

Short-wave heat cures from the inside and out, while medium-wave, long-wave and hot air primarily cure the surface.

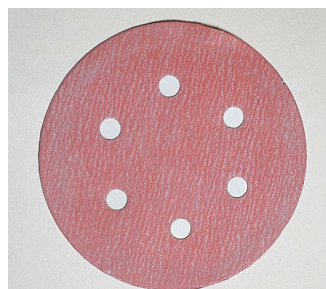

After only 3 minutes' curing you can polish with perfect results.



Despite a longer curing time with other products, only the surface is cured and the sanding paper becomes clogged.

CURING TIMES

Putty	2-3 min
Filler	3-7 min
Primer	5-8 min
Water-based paint	2-4 min
Base coat	4-8 min
Top coat	6-10 min
Clear coat	5-10 min
Filler on plastic	7-10 min
Top coat on plastic	15-18 min
Clear coat on plastic	15-18 min

The curing times are extremely short. The times above apply to the IRT PcAuto series. Add a minute or two for other models.

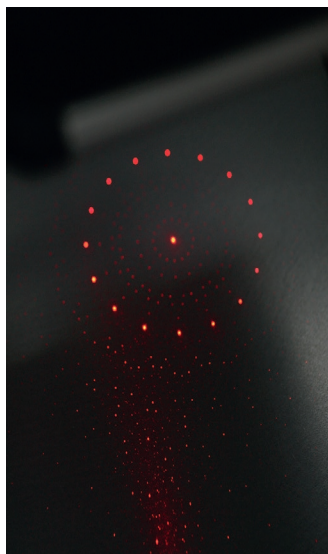

Built-in laser circle and distance sensor facilitates the settings.

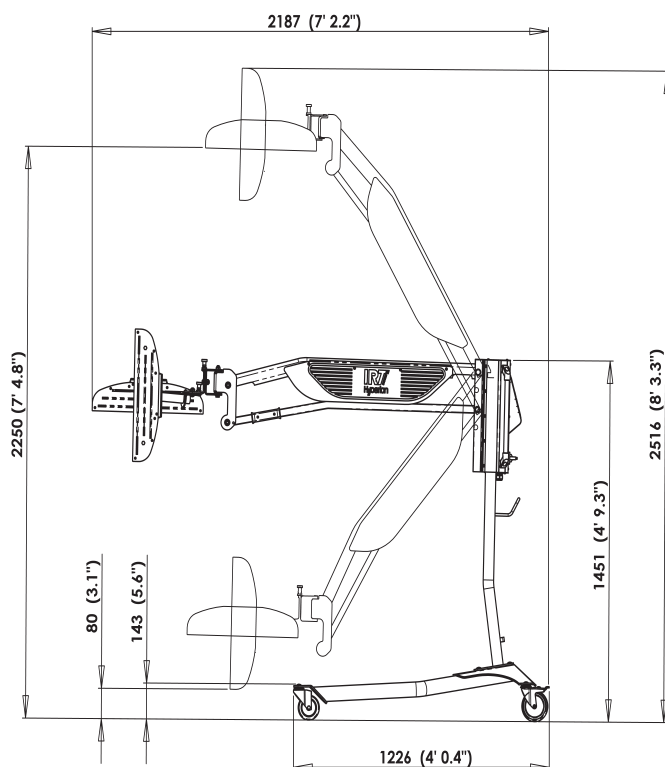

IRT 4-1, 4-2 PcAuto & IRT 3-1, 3-2 PcD

CURING SURFACES

IRT 4-1 PcAuto

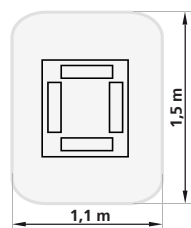

One cassette at a distance of 600 mm, on black sheet metal.

IRT 4-2 PcAuto

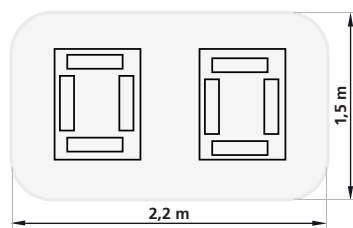

Two cassettes at a distance of 600 mm, on black sheet metal.

IRT 3-1 PcD/IRT 3 & 4 PrepCure

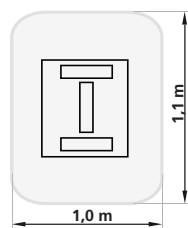

One cassette at a distance of 600 mm, on black sheet metal.

IRT 3-2 PcD

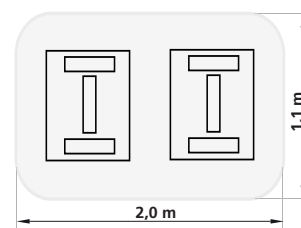

Two cassettes at a distance of 600 mm, on black sheet metal.

Hyperion features

	IRT 4-2 PcAuto	IRT 4-1 PcAuto	IRT 3-2 PcD	IRT 3-1 PcD	IRT 4 PrepCure	IRT 3 PrepCure	IRT 2 PrepCure	IRT 1 PrepCure
Even heat distribution	X	X	X	X	X	X	X	X
Short curing times	X	X	X	X	X	X	X	X
Environmentally friendly, efficient use of energy	X	X	X	X	X	X	X	X
24 carat gold coated reflectors with 97% reflection	X	X	X	X	X	X	X	X
Powerful ventilation provides the lamps with a service life of up to 20,000 operating hours	X	X	X	X	X	X	X	X
FreeForm reflectors for an unsurpassed drying surface	X	X	X	X	X	X	X	X
Efficient particle filter that creates a dust-free environment in the cassettes	X	X	X	X	X	X	X	X
Enclosed cassette cables	X	X	X	X	X	X	X	X
The angle of the arm provides increased reach	X	X	X	X	X	X	X	X
The stand is adapted also to dry high cars, e.g. SUVs	X	X	X	X	X	X	X	X
The arm is self-locking in all positions	X	X	X	X	X	X	X	X
Electronic distance sensor	X	X	X	X	X	X	X	X
Self-instructive programs	X	X	X	X	X	X	X	X
Computerised curing process	X	X	X	X	X	X	X	X
12 program pre-sets – 3 custom programs	X	X	X	X	X	X	X	X
Programs for plastic/metal/water/solvent	X	X	X	X	X	X	X	X
18 languages	X	X	X	X	X	X	X	X
Pyrometer for exact temperature control	X	X	X	X	X	X	X	X
Clear display with graphics showing the exact progress of the curing process	X	X	X	X	X	X	X	X
Computerised temperature monitoring of curing process	X	X	X	X	X	X	X	X
Laser circle indicates where temperature measurement takes place	X	X	X	X	X	X	X	X

IRT Systems is a registered trademark
© Hedson Technologies AB 2014

We reserve the right to make changes in design
and make reservations for any mistakes in writing.



Hedson Technologies AB
Hammarvägen 4
SE-232 37 ARLÖV, Sweden
Phone: +46 40 53 42 00
Fax: +46 40 43 29 01
www.hedson.se

