



**IRT**  
SYSTEM

# Superior Curing Technology

Fixed installations  
IRT Arches & Rails





# IRT Hyperion Rail Systems

## Simple and space saving curing

Reaching and maintaining the highest quality curing results have never been easier. With an IRT Hyperion Rail System, you can quickly manoeuvre the heater into the perfect curing position, reaching all parts of the car. The rails can be equipped with any number of heaters, all hanging on easy-glide, self-balanced cassette arms. Precious space between the cars can be saved, and no loose or trailing cables on the floor disturb the work process.

### Rails

The rails can be customized to suit all workshops. The cassettes are suspended in arms that glide easily and are self-balancing. As the electric power supply is integrated in the rails, there are no loose cables dragging along the floor disrupting work and raking up dust.

### Cost-effective

Investing in a rail system is a way for a paint shop to eliminate bottlenecks in production and substantially increase productivity. Energy costs will be lower and valuable workshop space will be freed up. A rail system constitutes a flexible solution. It is just as practical in a spray booth as in the prep station.

### FreeForm reflectors

With the introduction of the new, gold-coated, asymmetric FreeForm reflectors, we have developed the reflectors of the future.

Increased heat distribution provides a more even heat distribution implying that a larger area can be cured during the same period. A lot of energy is saved by only irradiating the object and not heating up the surrounding air.

All cables from the stand to the cassettes are enclosed. You avoid loose cables that can be burned or cause scratches in the paint, leaving your hands free to move the dryer.



## Cassette/lamps

There are two things that shorten the service life of an IR lamp: overheating and dust. An IRT lamp should last for 20,000 operating hours. For this reason, the Hyperion cassettes are equipped with powerful ventilation cooling both lamps and cassettes. This extends the life of the lamps significantly. The problems with dust have been resolved with a new, effective particle filter on the rear of the cassette. The software informs the operator of how much cleaning capacity is left in the particle filter and when it is time for the next filter replacement.

## Control unit

The most advanced Hyperion rail system, IRT 4-20, is equipped with advanced technology, such as temperature measurement, laser circle and digital distance sensor. 18 different languages can easily be set.

The laser circle shows where the measurement of the temperature on the curing area takes place, and the ultrasonic sensor measures the distance and signals when the distance is correct. The temperature is continuously measured, while the microprocessor regulates the effective output power upwards or downwards in a split second for optimal curing results.

As an operator, you can continuously monitor the curing process and receive information about such things as object temperature and elapsed and remaining program time.

Start the control unit, select a program – then dry.

### ADVANTAGES

- Simple installation
- Easy to move and set up in an exact position
- More flexible workshop
- No cables on the floor/ free areas
- Excellent fit in tight areas between cars



Easy to understand – easy to use

# IRT MotoCross Rail Systems

With the motorized IRT 4-200 you can dry all desired surfaces of the car.

Choose **Static** or **Dynamic mode** depending on area to be cured. In dynamic mode you can dry one section or the whole side of the car from front to back in one cycle.

Select the desired program for quick, easy and safe drying of your paint job (15 programs available). Large curing areas, gold coated FreeForm reflectors increase efficiency and save energy. Some call it smart. We call it Superior Curing Technology from IRT.

The IRT 4-200 MotoCross control panel is an extended version of the IRT Hyperion 4-20 PcAuto.

## Static mode

= Cross Rail Motor OFF

- Cassettes in any position
- Laser, pyrometer and distance sensor active
- Dry the selected area
- 18kW power – very short curing times
- 15 curing programs with individual settings available
- Health and safety in focus
  - ventilated cassettes
  - no hot parts
- Lamp service life 20.000 operating hours

## Dynamic mode

= Cross Rail Motor on

- Cassettes normally in vertical position
- Distance sensor active
- Dry a section or the whole side of the car from front to back in one cycle
- Choose direction, distance and program for the job
- 18 kW power – very short curing times
- Adjustment of speed and power level possible for each of the 15 programs
- Health and safety in focus
  - ventilated cassettes
  - no hot parts
- Lamp service life 20.000 operating hours





# IRT PowerCure

## SETS the standard for in-booth curing

### IRT PowerCure Saves

- Energy
- Time
- Space

High profitability in a car refinishing paint shop is obtained by processing repair jobs in the most efficient way. Bottlenecks and waiting times must be minimized so the car can be returned to its owner in the shortest possible time. The IRT PowerCure is designed to be installed inside the spray booth. The SETS features take in-booth drying to the next level.

They drastically shorten the curing times for all paint materials with a minimum of energy used.

### Energy

Why heat the whole spray booth and the whole car when most drying jobs comprises of 1-2 panels of the car? The IRT PowerCure will only heat and cure the selected panels of the car. The computer keeps track of position and status of the IRT PowerCure and will turn on- and off the individual lamps in a fraction of a second, in order to only use the energy needed for the curing job. This radically reduces the energy consumption and pays off the investment in a very short time.

### Time

When the painter has completed the finishing job and exits the spray booth he makes a short stop in front of the touch screen. This is where selections of panels to be dried and paint type are done quickly and easily. It is as easy as using your personal smartphone. A typical damage is cured in 10



The shape and positioning of the reflectors give an even heat distribution.



The IRT PowerCure automatically moves to the right position corresponding to the chosen panels.



The front and the back of the vehicle are easily cured as the wings can be angled towards the painted surface.



The vehicle and loose parts can be cured in the same drying cycle thanks to the intelligent software technology.



Loose parts are easy to cure. The IRT PowerCure detects the starting position and saves energy by only activating the necessary IR lamps.

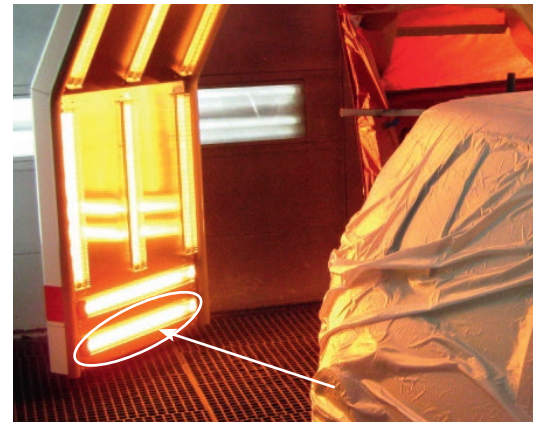

Optional – additional lamp for increased height.

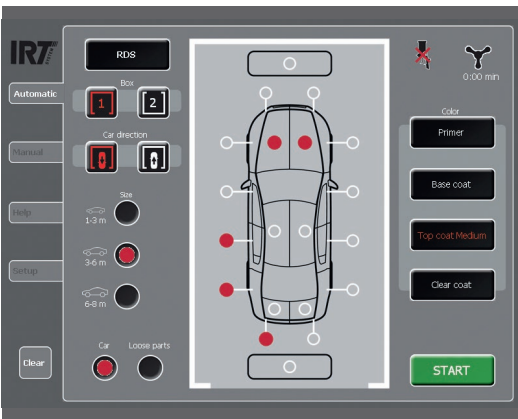

Simply choose the desired panels to be dried and start the curing process.



Optional – parking garage to protect the IR lamps



minutes or less. Leave the car for another 10 minutes to cool down.

It can then be removed from the spray booth, polished and processed further. Hence the IRT PowerCure offers you increased drying capacity as it turns your traditional booth into a rapid curing booth.

### Space

Space is often precious in a car refinishing paint shop. Traditionally two or more spray booths have been installed when more drying capacity was needed. This blocks and reduces the available space for other important parts of the shop such as the preparation bays. The IRT PowerCure gives you increased drying capacity by turning your traditional booth into a rapid curing booth and typically this gives you enough drying and spraying capacity without investing in a second or third booth. IRT PowerCure cures the paint from

the inside and out without retaining solvents and moisture. This is why the car can be polished and processed further immediately after cool down.

The result: you save space and improve the throughput of cars in your bodyshop.

# SETS

Saves Energy, Time & Space

# IRT Hyperion Rail Systems

## Technical description – IRT 3-20 PcD & IRT 4-20 PcAuto

Rail systems adapted for the prep station or the spray booth. The heater is suspended in permanently installed rails and can be moved laterally and vertically in all directions.

- No cables on the floor - free areas
- Electric power supply integrated into the rails
- Excellent fit in tight areas between cars
- Less risk for unintentional damage to the car
- Unique possibilities to position the cassettes
- Computerised curing process
- Gold-coated FreeForm reflectors for optimal heat distribution
- Pyrometer for exact temperature control (IRT 4-20 only)
- Laser circle indicates where temperature measuring takes place (IRT 4-20 only)
- Electronic distance sensor
- 12 pre-set and 3 custom programs
- Can cure all paint materials
- Efficient particle filter on the cassettes
- Powerful ventilation that cools the cassette and increases lamp life

The IRT Rail Systems can be equipped with many heaters, all hanging on easy-glide, self-balanced cassette arms. IRT rails are tailor-made to suit different working areas. Apart from carrying the heaters, the rails also house the electrical power source for the heaters without any loose or trailing cables disturbing the work process. The heaters are delivered with two cassettes. The cassettes are easy to adjust into

the correct position. The heater lamps are rigidly set in precision gold coated reflector bodies, ensuring the most even and efficient heat distribution. All lamps are cooled by ventilator fans.

Drying time and power is controlled by a microprocessor which, pre-programmed for different types of paint, automatically handles the entire curing process.

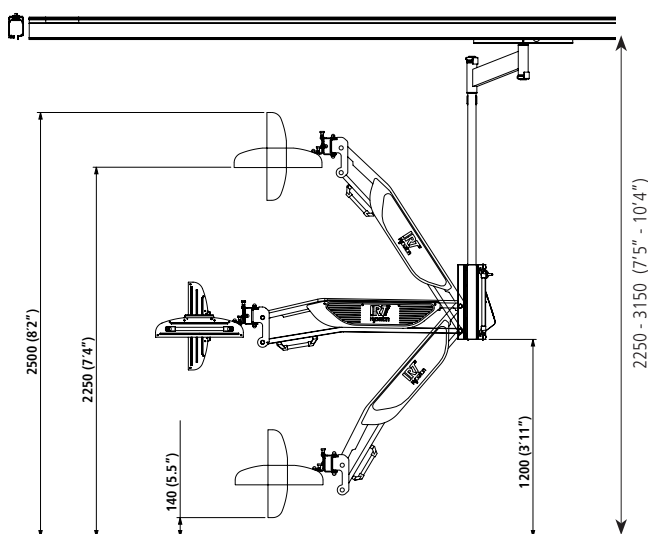

WEIGHT	
Traverse 7 m	
– 4-2 PcAuto & 3-2 PcD	165 kg
– MotoCross	210 kg
Rail without power supply	5 kg/m
Rail with power supply	7 kg/m
Heater 2 cassettes	60 kg

CURING TIMES	
Putty	2-3 min
Filler	3-7 min
Primer	5-8 min
Water-base paint	2-4 min
Base coat	4-8 min
Top coat	6-10 min
Clear coat	5-10 min
Filler on plastic	7-10 min
Top coat on plastic	15-18 min
Clear coat on plastic	15-18 min

The curing times are extremely short. The times above apply to the IRT PcAuto series. Add a minute or two for other models.

CURING SURFACES	
<p><b>IRT 4-20 PcAuto</b></p> <p>Two cassettes at a distance of 600 mm, on black sheet metal</p>	<p><b>IRT 3-20 PcD</b></p> <p>Two cassettes at a distance of 600 mm, on black sheet metal</p>

TECHNICAL DATA					
	4-2 PcAuto		3-2 PcD		MotoCross
Voltage	220-240V 3Ph ~/PE	380-420V 3Ph ~/PE	220-240V 3Ph ~/PE	380-420V 3Ph ~/PE	380-420V 3Ph/PE
Frequency	50-60 Hz	50-60 Hz	50-60 Hz	50-60 Hz	50 Hz
Current	30 A	17 A	15 A	9 A	26 A
Output power	12 kW	12 kW	6 kW	6 kW	18 kW
Fuse	32 A	32 A	16 A	16 A	-
Drying temp.	-	-	-	-	Max 170°C
Noise level	-	-	-	-	<70 dB (A)

## Technical description – IRT PowerCure Single & IRT PowerCure Double

The IRT PowerCure paint curing arch is intended for installation in a spray booth (IRT PowerCure Single) or for installation between two in line placed spray booths (IRT PowerCure Double).

The IRT PowerCure is mainly designed for drying 1-3 panels of the vehicle. It is also possible to utilise the arch for curing loose parts. IRT PowerCure is suspended by rails attached to the spray booth walls, easily adapted to all types of booths.

The rails house the electrical power source for the arch heaters without any loose or trailing cables disturbing the work process. This also reduces the wear and tear. During spraying, the arch is normally separated from the spray booth by an automatic roller door (not included in delivery).

The IRT- PowerCure arch comprises a number of IRT-heaters arranged in the form of an arch that passes over the parts of the vehicle that shall be cured, at a speed programmed in advance.

The IRT-heaters in the arch are arranged, and their output controlled for each colour group, in such a way as to ensure a uniform heat distribution over the zones to be cured.

An overspray protection and a safety surveillance system, connected to the spray booth ventilation and the spray gun air supply, ensure a safe operation.

Recommended minimum air flow in the booth is 0,15 m/sec.

The control equipment includes sensors and microprocessors which register and regulate, for example, power output, speed, distance and times. It adapts the function to suit different paint materials as well as the size and shape of the car.

IRT- PowerCure has turning side wings. Turning is made automatically if front or rear of the vehicle is selected.

The output for heating the bonnet, roof and boot respectively is adjusted by means of a laser distance sensor. This accomplishes an optimum heating of the selected zones.

The IRT-system does not heat up the air in the spray booth. The operator can re-enter the spray booth immediately after the curing process has been completed. The vehicle can directly be taken out of the booth. As soon as the heated surfaces have cooled to room temperature, polishing and other work can be made.

Thanks to the efficient cooling the IRT lamps last for about 20,000 working hours.

### DIMENSIONS

IRT PowerCure Single & Double

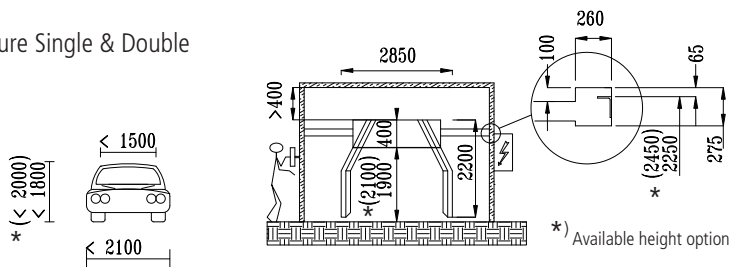

IRT PowerCure Single

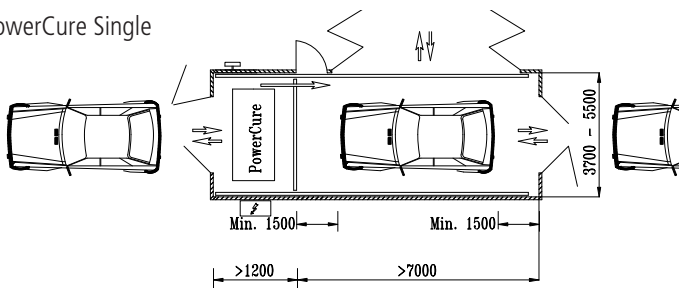

IRT PowerCure Double

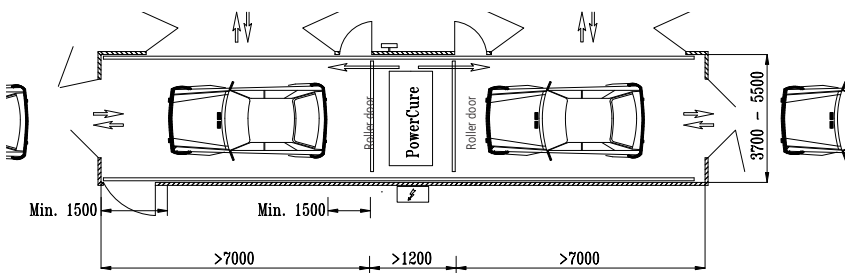

### CURING TIMES

Medium-sized Vehicles

	Base coat (approx)	Clear coat (approx)
Bonnet	4 min	7 min
Door	3 min	5 min

### ELECTRICAL DATA

Voltage	400 V, 3Ph ~/PE
Frequency	50-60 Hz
Installed power	54 kW
Used power preset from factory	43 kW max*

\* At 43 kW the PowerCure has to be fused with 63 A slow fuses

### ENERGY CONSUMPTION

Typical examples of energy consumption for IRT PowerCure. Clear coat on base coat, medium sized car, medium colour shade

Front wing	6 min	0,95 kWh
Door	5 min	0,95 kWh
Front wing + door	10 min	1,6 kWh
Hood	7 min	1,5 kWh
Hood + 2 wings	9 min	2,8 kWh
Complete car	26 min	15,8 kWh

# Basic features

## IRT Hyperion Rail systems

Even heat distribution

Short curing times

Environmentally friendly, efficient use of energy

24 carat gold coated reflectors with 97 % reflection

Powerful ventilation – lifetime of the lamps up to 20 000 hours

FreeForm reflectors for an unsurpassed drying surface

Efficient particle filter that creates a dust-free environment in the cassettes

Enclosed cassette cables

The angle of the arm provides increased reach

Possible also to dry high cars, e.g SUVs

The arm is self-locking in all positions

Electronic distance sensor

Self-instructive programs

Computerised curing process

12 pre-set programs – 3 custom programs

Programs for plastic/metal – water/solvent

18 languages

Pyrometer for exact temperature control (IRT 4-20 only)

Clear display with graphics showing the exact progress of the curing process

Computerised temperature monitoring of curing process

Laser circle indicates where temperature measurement takes place

All components of latest technical standard

## IRT PowerCure Paint Curing Arch

Mainly designed for drying 1-3 panels of the vehicle

Easy to cure loose parts

Curing of a complete car

No pre-heating of emitters necessary

Operates in one or two booths

Modern design and electronics

Light construction

Easy to service

Integrated ventilation system – protects electronics and lamps

Energy saving – the lamps are controlled individually

Extra lamp can be fitted to enable curing of high vehicles (option)

Integrated laser sensors for exact positioning

Integrated power transmission in rails

Arch garage parking in 1.2 m extended booth

Online control system – Drive, service, update and programming via Internet

Online supervision control (Option)

Touch screen

User-friendly graphics – self-instructive menus

Programs for all types of paint material – water, solvent, clear, base etc.

Very low running costs

Lifetime of lamps: 20 000 working hours

All components of latest technical standard

IRT Systems is a registered trademark  
© Hedson Technologies AB 2014

We reserve the right to make changes in design  
and make reservations for any mistakes in writing.



**Hedson Technologies AB**  
Hammarvägen 4  
SE-232 37 ARLÖV, Sweden  
Phone: +46 40 53 42 00  
Fax: +46 40 43 29 01  
www.hedson.se

