



AC Hydraulic^{A/S}
NO COMPROMISE



HEAVY DUTY JACKS

FOR MINING AND CONSTRUCTION INDUSTRIES





Since 1958 AC Hydraulic has been setting the standards for hydraulic lifting equipment for the automotive industry and with our new line of heavy duty jacks we are bringing our renowned know how and innovation to another level





The heavy duty jacks are strong and versatile but yet extremely easy to maneuver and position. Securing extremely stable heavy duty lifting on any challenging terrain combined with a high level of safety and minimal strain on the operators back

Due to our innovative chassis construction jack repair maintenance and even wheel changing can be made onsite keeping the jack in a top working condition

We do not compromise and trust that our heavy duty jacks will facilitate reductions in down time and set new standards for removing, disassembling and repairing machinery in all off-highway heavy duty industries





SAFETY ABOVE ALL

Our heavy duty jacks are designed to meet or exceed all safety demands in the mining and constructions industries

Optimum operator safety is ensured via a wide range of safety measures, a.o. safety valve to prevent overload, load lock or any failure due to hydraulic fluid loss, locking rings and a deadman's control on the handle

A wide range of accessories combined with an outstanding durability in all operating conditions our heavy duty jacks are designed to meet all needs



FACTS

Heavy duty jacks for the mining and construction industries

- Designed for off-road maintenance on heavy duty industrial machinery
- All steel, heavy duty chassis build to fit harsh environment
- Large rubber tires allow easy positioning on challenging surfaces
- Innovative chassis construction facilitates jack repair and even wheel changing on site
- High ground clearance for clearing rail and rough terrain
- Multiple position handle for easy tilt back and ergonomic moving
- Safety valve prevents overload, load lock or any failure due to hydraulic fluid loss
- Handle with dead-man's control for optimum safety during lifting and lowering
- 2 lifting eyes and tilt-back handle position for easy jack handling and transport
- Can be supplied with extensions and locking rings (not standard)

ACCESSORIES

Locking rings & extensions

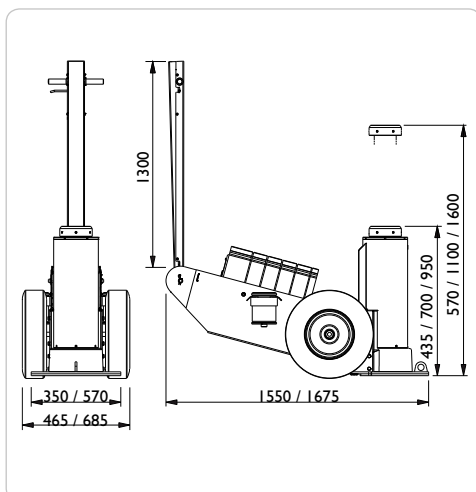

	100-IL / 150-IL	100-I / 150-I	100-IH / 150-IH
Capacity	100 / 150 t	100 / 150 t	100 / 150 t
Min. height	435 mm	700 mm	950 mm
Max. height	570 mm	1100 mm	1600 mm
Frame length	1550 mm	1675 mm	1675 mm
Handle length	1300 mm	1300 mm	1300 mm
Width	350 mm	570 mm	570 mm
Width (with wheels)	465 mm	685 mm	685 mm
Air supply	10 bar	10 bar	10 bar
Air consumption	1200 l/min	1200 l/min	1200 l/min
Weight	332 kg	476 kg	546 kg
Ground clearance	40 mm	65 mm	65 mm

100-IL



150-IL



100-I



150-I



100-IH



150-IH



Our products are not only 100% Danish designed and engineered – all parts are MADE IN DENMARK at our modern 15.000 m² high-tech production plant. Robots, laser cutting machines and state-of-the-art CNC machinery ensure full control at all stages of production. Our state of the art production facilities combined with our 130 highly skilled employees allows us to live our business philosophy of

NO COMPROMISE







AC Hydraulic A/S

Fanøvej 6 • DK-8800 Viborg • Tel. +45 8662 2166 • Fax +45 8662 2988
E-mail: ac@ac-hydraulic.dk • www.ac-hydraulic.com