

# Catalogo Generale General Catalogue

MARCO  
**TOOLS**  
BY SPIN

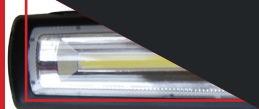

# 2018

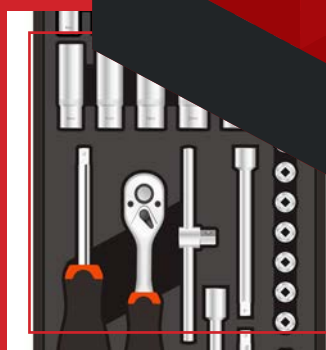

MARCO  
TOOLS  
BY SPIN

Professional  
Garage Equipment  
AUTOATTREZZATURE PROFESSIONALI

Cod.	LP	Pag.	Cod.	LP	Pag.	Cod.	LP	Pag.	Cod.	LP	Pag.
01.000.08	78,00 €	55	02.009.19	12.000,00 €	53	03.031.31	159,00 €	64	04.053.07	43,00 €	84
01.000.08IMP	41,00 €	55	02.009.20	16.800,00 €	53	03.031.32	690,00 €	23	04.053.08	312,00 €	82
01.000.37	12,00 €	57	02.009.21	24.500,00 €	53	03.031.33	220,00 €	23	05.008.01	8,60 €	95
01.000.39	27,00 €	57	02.009.22	3.670,00 €	53	03.036.04	13,00 €	80	05.013.03	9,00 €	95
01.000.41	27,96 €	57	02.009.23	6.240,00 €	53	03.036.17	198,00 €	53	05.019.03	248,00 €	78
01.000.42	28,00 €	57	02.009.24	969,00 €	52	03.036.18NEW	380,00 €	22	05.036.00	59,00 €	113
01.000.79	85,00 €	54	02.009.25	1.380,00 €	52	03.036.22	792,00 €	71	05.049.00	196,00 €	87
01.000.100	138,00 €	55	02.016.04	148,00 €	81	03.036.23	128,00 €	71	05.056.00	46,00 €	73
01.000.103	39,50 €	55	02.017.00	1.440,00 €	108	03.036.24	198,00 €	71	05.056.01	56,00 €	73
01.000.122	27,00 €	57	02.020.05	332,00 €	81	03.036.25	27,50 €	79	05.056.03	27,00 €	73
01.000.124	38,00 €	57	02.022.113	286,00 €	76	03.036.26	138,00 €	22	05.056.07	88,00 €	73
01.000.125	39,50 €	57	02.022.91	22,00 €	80	03.036.27	107,00 €	22	05.056.08	14,00 €	73
01.000.127	33,00 €	57	03.000.35	12,60 €	62	03.036.28	202,00 €	71	05.056.09	118,00 €	74
01.000.168	94,00 €	55	03.000.36	13,60 €	62	04.003.04	320,00 €	29	05.056.10	45,00 €	77
01.000.168IMP	49,00 €	55	03.000.38	398,00 €	63	04.003.08	168,00 €	29	05.056.11	46,00 €	77
01.000.177	13,60 €	57	03.000.40	496,00 €	63	04.003.09	62,00 €	29	05.056.12	54,00 €	77
01.000.178	30,00 €	57	03.000.42	95,00 €	49	04.003.11	440,00 €	29	05.056.13	44,00 €	74
01.000.179	14,50 €	57	03.000.45	74,00 €	63	04.005.02	169,00 €	40	05.056.14	43,00 €	78
01.000.180	33,50 €	57	03.000.47	13,00 €	64	04.006.02	267,00 €	40	05.056.15	53,00 €	77
01.000.181	33,00 €	57	03.000.49	36,00 €	50	04.009.01	120,00 €	40	05.056.16	44,00 €	74
01.000.187	a richiesta on request	57	03.001.06	1.400,00 €	62	04.009.02	98,00 €	40	05.058.01	118,00 €	72
01.000.202	343,00 €	54	03.015.00	380,00 €	30	04.009.03	78,00 €	40	05.058.07	38,50 €	72
01.000.203	375,00 €	55	03.015.01	780,00 €	30	04.012.04	1.150,00 €	111	05.058.08	12,80 €	72
01.000.208	18,50 €	57	03.015.03	240,00 €	28	04.012.05	350,00 €	111	05.058.09	40,00 €	72
01.000.210	31,50 €	57	03.015.04	480,00 €	27	04.012.06	350,00 €	111	05.060.00	48,00 €	49
01.000.214	260,00 €	55	03.016.00	550,00 €	30	04.012.07	55,00 €	111	05.060.02	24,00 €	49
01.000.215	272,00 €	59	03.016.01	460,00 €	28	04.013.05	39,80 €	112	05.060.03	34,00 €	49
01.000.224	346,00 €	59	03.018.01	1.142,00 €	30	04.014.01	105,00 €	112	05.060.04	165,00 €	49
01.000.225	728,00 €	54	03.018.04	25,00 €	30	04.014.02	a richiesta on request	113	05.062.00	98,00 €	80
01.000.231	102,00 €	114	03.019.01	1.590,00 €	30	04.018.00	375,00 €	110	05.062.01	45,00 €	79
01.000.234	1.392,00 €	61	03.020.01	146,00 €	34	04.018.05	432,00 €	110	05.062.02	19,00 €	80
01.000.239	307,00 €	59	03.020.02	330,00 €	34	04.018.06	87,00 €	110	05.062.03	19,80 €	95
01.000.241	39,00 €	61	03.020.06	196,00 €	34	04.019.02	579,00 €	110	05.062.04	20,00 €	95
01.000.242	44,00 €	61	03.020.07	236,00 €	32	04.020.00	102,00 €	114	05.062.05	17,00 €	74
01.000.245	520,00 €	60	03.020.08	396,00 €	33	04.024.01	118,00 €	83	05.062.06	22,00 €	75
01.001.91	119,00 €	54	03.024.17	1.280,00 €	37	04.024.02	202,00 €	83	05.064.00	108,00 €	95
01.017.04	1.300,00 €	56	03.024.20	630,00 €	36	04.029.01	102,00 €	82	05.066.01	296,00 €	93
01.017.05	1.275,00 €	56	03.024.21	a richiesta on request	37	04.031.00	470,00 €	109	05.066.02	55,00 €	94
01.017.06	1.142,00 €	56	03.024.30	56,00 €	39	04.033.00	890,00 €	109	05.066.03	21,60 €	93
01.090.00	90,00 €	55	03.024.31	79,00 €	39	04.034.00	365,00 €	109	05.066.04	6,86 €	93
01.090.01	550,00 €	55	03.024.32	118,00 €	39	04.042.00	29,00 €	95	05.066.05	16,00 €	93
01.090.04	90,00 €	55	03.024.33	78,00 €	39	04.042.01	29,00 €	95	05.066.06	780,00 €	99
01.090.07	44,00 €	54	03.029.14	750,00 €	104	04.043.00	98,00 €	82	05.066.06R1	128,00 €	99
01.090.08	385,00 €	54	03.029.22	1.450,00 €	107	04.043.01	32,00 €	82	05.066.06R2	29,00 €	99
01.090.10	78,00 €	55	03.029.30	a richiesta on request	106	04.051.00	63,00 €	115	05.066.07	1.040,00 €	99
01.090.11	21,60 €	55	03.029.33	990,00 €	104	04.051.01	63,00 €	115	05.066.07R1	154,00 €	99
01.090.12	98,00 €	55	03.029.37	a richiesta on request	106	04.051.02	370,00 €	115	05.066.07R2	35,00 €	99
02.000.43	59,00 €	52	03.029.39	990,00 €	106	04.052.00	15,00 €	112	05.067.01	109,00 €	79
02.000.96	150,00 €	53	03.029.40	a richiesta on request	106	04.052.02	25,00 €	114	05.073.08	74,00 €	46
02.009.13	330,00 €	52	03.029.41	a richiesta on request	106	04.052.03	30,00 €	114	05.073.10	135,00 €	44
02.009.15	209,00 €	52	03.031.01	198,00 €	64	04.052.04	33,00 €	114	05.073.13DIN	42,00 €	46
02.009.16	570,00 €	52	03.031.13	328,00 €	88	04.052.05	75,00 €	114	05.073.13T	38,00 €	45
02.009.17	692,00 €	52	03.031.16	128,00 €	64	04.053.00	69,00 €	84	05.073.20T	49,00 €	46
02.009.18	8.700,00 €	53	03.031.29	190,00 €	62	04.053.05	428,00 €	84	05.073.21	7,20 €	47

Cod.	LP	Pag.	Cod.	LP	Pag.	Cod.	LP	Pag.	Cod.	LP	Pag.
05.073.22	8,20 €	47	05.084.15	108,00 €	16	05.088.70	20,50 €	14	05.090.52	122,00 €	103
05.073.23	96,00 €	47	05.084.16	56,00 €	16	05.088.71	90,00 €	20	05.090.54	44,00 €	68
05.073.24T	32,00 €	44	05.084.17	232,00 €	16	05.088.72	271,00 €	15	05.090.55	44,00 €	68
05.073.24TK	92,00 €	44	05.084.18	515,00 €	70	05.088.73	360,00 €	15	05.090.56	44,00 €	68
05.073.25T	60,00 €	44	05.084.19	352,00 €	18	05.088.74	490,00 €	15	05.090.57	44,00 €	68
05.073.25TK	120,00 €	44	05.084.21	68,00 €	50	05.088.75	407,00 €	16	05.090.58	48,00 €	68
05.073.26	190,00 €	42	05.084.22	472,00 €	18	05.088.76	190,00 €	19	05.090.61	54,00 €	68
05.073.27DIN	75,00 €	45	05.084.23	373,00 €	18	05.088.77	600,00 €	5	05.090.62	40,00 €	88
05.073.28	28,00 €	48	05.085.00	64,00 €	19	05.088.78	1.140,00 €	6	05.090.63	38,50 €	88
05.073.29	34,80 €	48	05.085.01	46,00 €	19	05.088.79	49,70 €	20	05.090.64	65,00 €	88
05.074.05	190,00 €	92	05.085.04C	534,00 €	85	05.088.80	178,00 €	11	05.090.65	78,00 €	88
05.075.05	139,00 €	51	05.085.04L	620,00 €	85	05.088.81	84,00 €	14	05.090.66	9,00 €	68
05.075.06	44,00 €	51	05.085.05	184,00 €	86	05.088.82	421,00 €	10	05.090.67	154,00 €	69
05.075.07	46,00 €	51	05.085.07	70,00 €	88	05.088.84	737,00 €	10	05.090.68	96,00 €	69
05.075.08	39,50 €	50	05.085.08	310,00 €	26	05.088.85	942,00 €	10	05.090.70	79,00 €	81
05.075.09	76,00 €	50	05.085.09	1.498,00 €	85	05.088.86	34,00 €	14	05.090.72	320,00 €	78
05.075.10	510,00 €	24	05.085.10	186,00 €	86	05.089.00	90,00 €	101	05.090.73	23,00 €	56
05.075.11	5,00 €	25	05.085.11	125,00 €	21	05.090.00	83,00 €	101	05.090.75	13,00 €	79
05.075.12	16,80 €	25	05.086.00	179,00 €	89	05.090.01	93,90 €	101	05.090.76	42,00 €	79
05.075.13	22,00 €	25	05.086.04	92,00 €	89	05.090.02	93,90 €	101	05.090.77	92,00 €	69
05.075.14	72,00 €	25	05.086.05	129,00 €	89	05.090.05	110,00 €	101	05.090.78	99,00 €	69
05.075.15	72,00 €	25	05.086.11	28,90 €	91	05.090.07	62,00 €	83	05.090.79	173,00 €	69
05.075.16	1.642,00 €	24	05.086.12	49,50 €	91	05.090.08	68,00 €	84	05.090.80	176,00 €	69
05.075.17	702,00 €	25	05.086.14	128,00 €	90	05.090.10	114,90 €	26	05.090.81	226,00 €	69
05.075.18	307,00 €	25	05.086.15	155,00 €	90	05.090.13	70,00 €	26	05.090.83	70,00 €	75
05.075.20	12,00 €	25	05.086.16	194,00 €	90	05.090.14	28,00 €	102	05.090.84	96,00 €	75
05.075.21	22,90 €	25	05.087.02	190,00 €	96	05.090.15	59,80 €	102	05.090.85	22,00 €	92
05.075.22	12,80 €	25	05.087.03	129,00 €	87	05.090.16	110,00 €	100	05.090.86	50,00 €	92
05.075.23	41,50 €	25	05.087.04	149,00 €	87	05.090.17	35,00 €	100	05.090.88	10,30 €	68
05.075.24	5,50 €	25	05.087.06	157,00 €	17	05.090.22	18,00 €	95	05.091.00	150,00 €	94
05.075.25	20,00 €	25	05.087.10	54,00 €	96	05.090.23	31,00 €	103	05.091.01	298,00 €	94
05.075.26	5,50 €	25	05.087.13	102,00 €	90	05.090.24	26,00 €	64	05.091.02	103,00 €	94
05.075.27	80,00 €	25	05.087.14	120,00 €	87	05.090.25	45,00 €	94	05.091.03DP	160,00 €	67
05.075.28	12,00 €	25	05.087.16	230,00 €	87	05.090.26	49,50 €	13	05.091.03DPR1	23,50 €	67
05.078.04	66,00 €	103	05.088.02	80,00 €	20	05.090.29	113,00 €	13	05.091.04DP	174,00 €	66
05.078.07	80,00 €	75	05.088.03	39,90 €	20	05.090.29B	115,00 €	13	05.091.04DPR1	23,50 €	66
05.081.04	17,00 €	29	05.088.06	973,00 €	10	05.090.30	50,00 €	12	05.091.05DP	213,00 €	65
05.083.00	48,00 €	86	05.088.17	166,00 €	20	05.090.31	54,20 €	12	05.091.05DPR1	37,00 €	65
05.083.01	44,00 €	86	05.088.25	54,00 €	20	05.090.32	43,80 €	12	05.092.00	22,00 €	96
05.083.02	32,50 €	14	05.088.40	190,00 €	11	05.090.33	53,80 €	12	05.092.01	32,00 €	96
05.083.03	49,00 €	14	05.088.44	379,00 €	10	05.090.34	38,40 €	12	05.096.03	15,50 €	49
05.084.01	183,00 €	17	05.088.47	521,00 €	12	05.090.35	28,60 €	12	05.096.04	6,40 €	49
05.084.02	258,00 €	17	05.088.48	316,00 €	12	05.090.36	26,50 €	12	05.098.01	46,00 €	80
05.084.03	389,00 €	17	05.088.50 B-EVA	855,00 €	8	05.090.37	16,40 €	12	05.098.02	71,00 €	82
05.084.04	118,00 €	26	05.088.50 G-EVA	855,00 €	8	05.090.38	16,40 €	13	05.100.00	12,80 €	28
05.084.05P	242,00 €	21	05.088.50 R-EVA	855,00 €	8	05.090.39	47,80 €	13	05.100.01	12,80 €	28
05.084.06	360,00 €	19	05.088.53	695,00 €	10	05.090.40	22,80 €	13	05.102.03	170,00 €	97
05.084.06	360,00 €	96	05.088.55	452,00 €	10	05.090.41	33,00 €	13	WZRIC0287	28,00 €	80
05.084.07	157,00 €	16	05.088.56	768,00 €	10	05.090.42	27,30 €	13			
05.084.10	420,00 €	70	05.088.60	92,00 €	72	05.090.43	24,60 €	13			
05.084.11	870,00 €	70	05.088.61	65,00 €	20	05.090.44	37,40 €	13			
05.084.12	24,00 €	16	05.088.62	900,00 €	10	05.090.47	119,00 €	83			
05.084.13	33,00 €	16	05.088.67	39,90 €	64	05.090.48	38,00 €	102			
05.084.14	46,00 €	16	05.088.69	15,00 €	14	05.090.49	169,00 €	100			





# 8102 Catalogo Generale

General Catalogue

> Le foto presenti sul catalogo sono puramente indicative e possono essere cambiate senza preavviso.  
> The pictures in the catalogue have merely explanatory purposes and can be changed with no warning.  
> Las imagenes tienen una función simplemente explicativa y pueden ser cambiadas en cualquier momento.





Cod. 05.088.77

€ 600,00

**CARRELLO 7 CASSETTI  
7-DRAWER ROLL CAB  
CARRITO DE 7 CAJONES**

(VUOTO) (EMPTY) (VACIO)

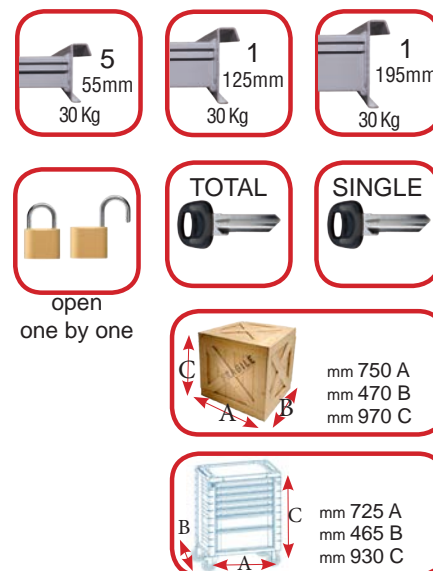

**CON ANTIRIBALTAMENTO E PIANO IN ACCIAIO INOX  
WITH ANTI-ROLL SYSTEM AND STAINLESS STEEL COUNTERTOP  
CON SISTEMA ANTI-VUELCO Y ENCIMERA DE ACERO INOXIDABLE**

1. Piano di lavoro in acciaio inox
2. Maniglie cassette in alluminio
3. Guide con cuscinetti (apertura cassetto 100%)
4. Sistema di bloccaggio interno
5. 5 cassette H = 55mm, 1 cassetto H = 125mm, 1 cassetto H = 195mm
6. Ruote alta portata da 125mm
7. Sistema di apertura cassette (1x1) antiribaltamento
8. Angoli in plastica anti-urto
9. Maniglione di manovra in gomma
10. Comparti porta minuterie fori per cacciaviti
11. Ganci porta utensili

1. Stainless steel worktop
2. Drawers' handle made of aluminum
3. Ball-bearing slides (drawer's opening 100%)
4. Self-locking internal system
5. 5 drawers H = 55mm, 1 drawer H = 125mm, 1 drawer H = 195mm
6. High-performance 125mm wheels
7. Drawers opening anti-tilt system (1x1)
8. Impact-resistant plastic corners
9. Rubber operating handle
10. Compartments for small parts holes for screwdrivers
11. Tool-holding hooks

1. Superficie de trabajo de acero inoxidable
2. Mango cajones de aluminio
3. Guías telescópicas con cojinetes de bolas (apertura del cajón 100%)
4. Sistema interno autoblocante
5. 5 cajones A = 55mm, 1 cajon A = 125mm, 1 cajon A = 195mm
6. Ruedas de 125mm de alto rendimiento
7. Sistema de apertura cajones anti-inclinación (1x1)
8. Esquinas de plástico resistente a los impactos
9. Mango de manejo de goma
10. Compartimientos para piezas pequeñas agujeros para destornilladores
11. Ganchos portaherramientas



CON ANTIRIBALTAMENTO E PIANO IN ACCIAIO INOX  
WITH ANTI-ROLL SYSTEM AND STAINLESS STEEL COUNTERTOP  
CON SISTEMA ANTI-VUELCO Y ENCIMERA DE ACERO INOXIDABLE

Cod. 05.088.78

€1.140,00

**CARRELLO 7 CASSETTI**  
**7-DRAWER ROLL CAB**  
**CARRITO DE 7 CAJONES**



con 231 utensili (5 cassetti pieni)  
su supporto di morbida spugna  
with 231 tools (5 full drawers)  
on soft sponge support  
con 231 herramientas (5 cajones llenos)  
en soporte de esponja blanda

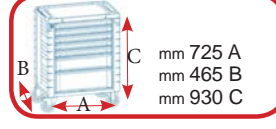
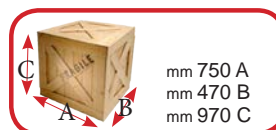

open  
one by one

Set bussole da 3/8-1/2" - Kit of sockets 3/8-1/2" - Juego de llaves 3/8-1/2" (74pcs).

Il set include - The kit includes - El kit incluye

19pcs bussole CR-V 1/2"	19pcs sockets CR-V 1/2"	19pcs llaves CR-V 1/2"	8-32MM
15pcs bussole CR-V 3/8"	15pcs sockets CR-V 3/8"	15pcs llaves CR-V 3/8"	9-24MM
10pcs bussole CR-V 1/2"	10pcs bussole CR-V 1/2"	10pcs llaves CR-V 1/2"	8-18MM LUNGHE
9pcs bussole CR-V 3/8"	9pcs sockets CR-V 3/8"	9pcs llaves CR-V 3/8"	8-17MM
8pcs bussole CR-V 3/8"	8pcs sockets CR-V 3/8"	8pcs llaves CR-V 3/8"	E8-E20
2pcs giunti	2pcs joints	2pcs llaves articoladas	3/8", 1/2"
2pcs cricchetti	2pcs pawls	2pcs carracas	3/8", 1/2"
4pcs bussole a impatto (CR-Mo)	4pcs impact sockets (CR-Mo)	4pcs llaves de impacto (CR-Mo)	17, 19, 21, 23MM
2pcs barre di estensione	2pcs extension bars	2pcs barras de extension	3/8, 1/2"
1pc impugnatura per inserti	1pc handle for inserts	1pc mango para insertos	1/2"
2pcs bussole per candele	2pcs sockets for spark plugs	2pcs llaves para bujias	16-21MM

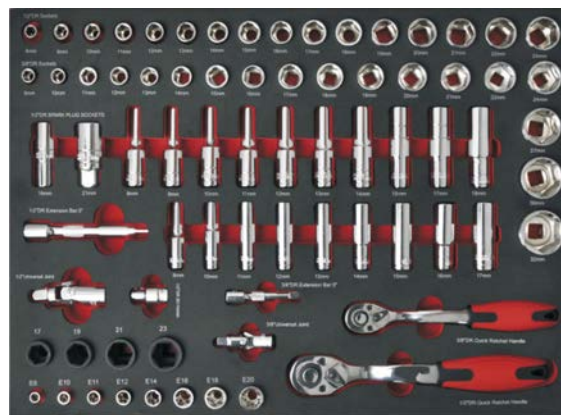

Set 99pcs utensili assortiti - Kit of 99pcs assorted tools - Juego de 99pcs herramientas variadas



3pcs chiavi esagonali CR-V	3pcs hexagonal wrenches CR-V	3pcs llaves hexagonales CR-V	1,5-2-2,5mm
9pcs chiavi esagonali con punta tonda CR-V	9pcs hexagonal wrenches with ball tips CR-V	9pcs llaves hexagonales con punta redonda CR-V	1,5-10mm
9pcs chiavi torx CR-V da	9pcs torx wrenches CR-V from	9pcs llaves torx CR-V da	T10 a T50
22pcs inserti 3/8" a cacciavite CR-V	22pcs screwdriver inserts 3/8" CR-V	22pcs puntas 3/8" de destornillador CR-V	vari profili
21pcs inserti 1/4" a cacciavite CR-V	21pcs screwdriver inserts 1/4" CR-V	21pcs puntas 1/4" de sdestornillador CR-V	vari profili
13pcs bussole 1/4" CR-V	13pcs socket wrenches 1/4" CR-V	13pcs llaves de tubo 1/4" CR-V	4-14mm
10pcs bussole lunghe 1/4" CR-V	10pcs long socket wrenches 1/4" CR-V	10pcs llaves de tubo larghe 1/4" CR-V	4-13mm
2pcs barre scorrevoli	2pcs sliding bars	2pcs barras correderas	1/2" - 1/4"
4pcs barre di estensione	4pcs extension bars	4pcs barras de extension	1/4" x50, 1/4" x100, 3/8" x150, 1/2" x250mm
1pc barra di estensione flessibile	1pc flexible extension bar	1pc barra de extension flexible	1/4"
1pc impugnatura da	1pc handle	1pc mango	1/4"
1pc giunto universale da	1pc universal joint	1pc junto universal	1/4"
1pc cricchetto CR-V da	1pc ratchet CR-V	1pc carraca CR-V	1/4"





Set di 22 chiavi combinate misura  
Set of 22 combined wrenches measurement  
Juego de 22 llaves combinadas medidas

6,	7,	8,	9,	10,	11,
12,	13,	14,	15,	16,	17,
18,	19,	20,	21,	22,	23,
24,	27,	30,	32mm		

Set 23 cacciaviti - Kit 23pcs screwdrivers - Juego de 23pcs destornilladores

Punta piana Flat Tip Puntas planas	6x38, 3x75, 5x75, 6x100, 8x150mm
Punta a croce Cross-tip Puntas en cruz	PH2 x38, PH0 x75, PH1 x75, PH2 x100, PH3 x150mm
Torx	T5x75, T6x75, T7x75, T8x75, T9x75, T10x75, T15x100, T20x100, T25x100, T27x125, T30x125, T40x150mm
Barra di estrazione Pry bar Barra de extraccion	2pzx200mm

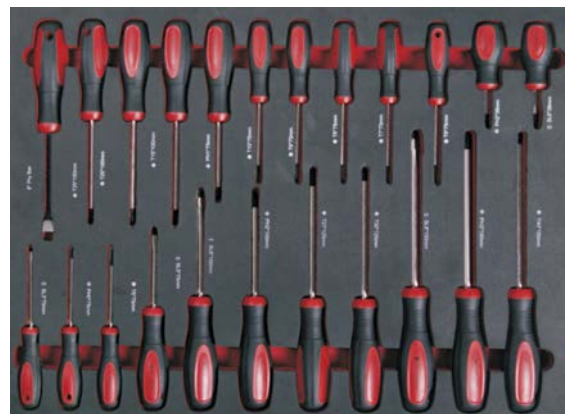

Set pinze - chiavi poligonali - martelli  
3pcs tronchesi, pinza becchi dritti, pinza combinata  
2pcs martello 300gr - mazzuolo plastica  
8pcs chiavi poligonali 6x7, 8x9, 10x11, 12x13, 14x15, 16x17,

Kit of pliers - ring spanners - hammers  
3pcs clippers, straight nose pliers, combined pliers  
2pcs hammer 300gr - plastic mallet  
8pcs ring spanners 6x7, 8x9, 10x11, 12x13, 14x15, 16x17, 18x19

Kit de pinzas - llaves de boca - martillos  
3pcs tijeras, alicates de punta fina, alicates combinados  
2pcs martillo 300gr - mazo de plástico  
8pcs llaves de boca 6x7, 8x9, 10x11, 12x13, 14x15, 16x17, 18x19

Acciaio inossidabile  
Stainless steel  
Acero inoxidable

Spigoli antiurto  
Shockproof edges  
Bordes a prueba de golpes

Guide a scorrimento  
Ball bearing guides  
Guías de rodamiento de bolas

Manico in gomma  
Rubber handle  
Mango de goma



Ruota Ø125mm con freno  
Wheel Ø125mm with brake  
Rueda Ø125mm con freno

Comparti porta minuterie  
Small items compartment  
Compartimento para artículos pequeños

Ganci laterali porta utensili  
Tool-holding lateral hooks  
Ganchos laterales porta-herramientas

Maniglie cassetti in alluminio  
Drawers' handle made of aluminum  
Mango cajones en aluminio





€ 855,00

HOT!

CON ARPIONI DI BLOCCO, CHIUSURA CENTRALIZZATA E SUPERFICI POGGIA UTENSILI IN SPUGNA

WITH BLOCKING SYSTEM ON THE DRAWERS, CENTRAL LOCKING AND TOOL-HOLDING SPONGE SURFACES

CON SISTEMA DE BLOQUEO EN LOS CAJONES, SISTEMA DE CIERRE CENTRALIZADO Y SOPORTE EN ESPONJA PARA LAS HERRAMIENTAS

Set bussole da 1/4" - 3/8" - 1/2" (72pcs)

Kit of socket wrenches 1/4" - 3/8" - 1/2" (72pcs)

Juego de llaves de tubo 1/4" - 3/8" - 1/2" (72pcs)

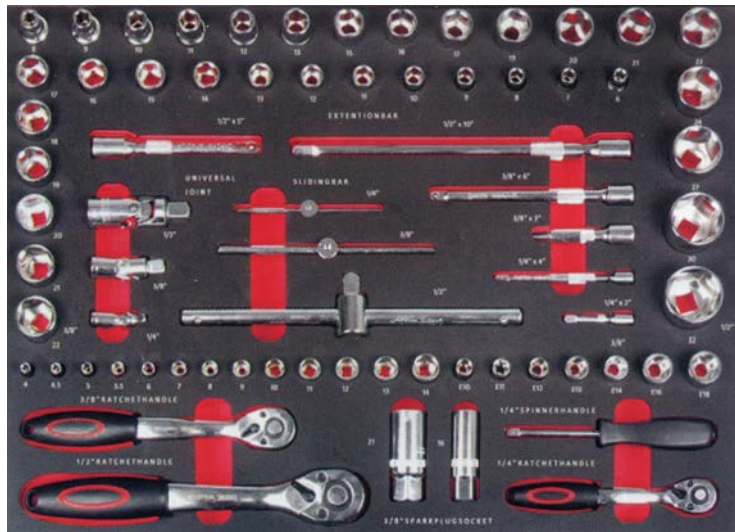

- **Cod. 05.088.50 R-EVA** ROSSO RED ROJO
- **Cod. 05.088.50 G-EVA** GRIGIO GREY GRIS
- **Cod. 05.088.50 B-EVA** BLU BLU AZUL

**CARRELLO 7 CASSETTI  
7-DRAWER ROLL CAB  
CARRITO DE 7 CAJONES**

con 196 utensili  
con alloggiamento in morbida spugna  
with 196 tools  
in soft sponge holding base  
con 196 herramientas  
en base de apoyo de esponja blanda

5  
75mm  
25 Kg

1  
130mm  
30 Kg

1  
150mm  
30 Kg

C  
A B  
mm 770 A  
mm 465 B  
mm 980 C

C  
A B  
mm 790 A  
mm 477 B  
mm 850 C

TOTAL

SINGLE

ANTI SHOC  
PROTECTION

Kg  
76,2

IL SET INCLUDE: THE KIT INCLUDES: EL KIT INCLUYE:

17pcs bussole 1/2"	17pcs socket wrenches	17pcs llaves de tubo	1/2" 8-9-10-11-12-13-14-15-16-17-19-20-21-22-24-27-32mm
1pc giunto girevole	1pc swivel joint	1pc junta giratoria	1/2"
1pc barra scorrevole	1pc sliding bar	1pc barra corredera	1/2"
1pc barra di estensione	1pc extension bar	1pc barra de extension	1/2" x250mm
1pc cricchetto	1pc ratchet	1pc carraca	1/2"
13pcs bussole da	13pcs socket wrenches	13pcs llaves de tubo	1/4" 4-4,5-5-5,5-6-7-8-9-10-11-12-13-14mm
1pc giunto girevole	1pc swivel joint	1pc junta giratoria	1/4"
1pc barra scorrevole	1pc sliding bar	1pc barra corredera	1/4"
1pc barra di estensione	1pc extension bar	1pc barra de extension	1/4" x50mm
1pc barra di estensione	1pc extension bar	1pc barra de extension	1/4" x100mm
1pc cricchetto	1pc ratchet	1pc carraca	1/4"
1pc impugnatura	1pc handle	1pc mango	1/4"
17pcs bussole da	17pcs socket wrenches	17pcs llaves de tubo	3/8" 6-7-8-9-10-11-12-13-14-15-16-17-18-19-20-21-22mm
1pc giunto universale	1pc universal joint	1pc junta universal	3/8"
1pc barra scorrevole	1pc sliding bar	1pc barra corredera	3/8"
1pc barra di estensione	1pc extension bar	1pc barra de extension	3/8" x76mm
1pc barra di estensione	1pc extension bar	1pc barra de extension	3/8" x152mm
2pcs chiavi per candele	2pcs wrenches for spark plugs	2pcs llaves para bujias	3/8" 16-21mm
7pcs bussole torx	7pcs torx wrenches	7pcs llaves torx	E10-E11-E12-E14-E16-E18-E20
1pc cricchetto	1pc ratchet	1pc carraca	3/8"

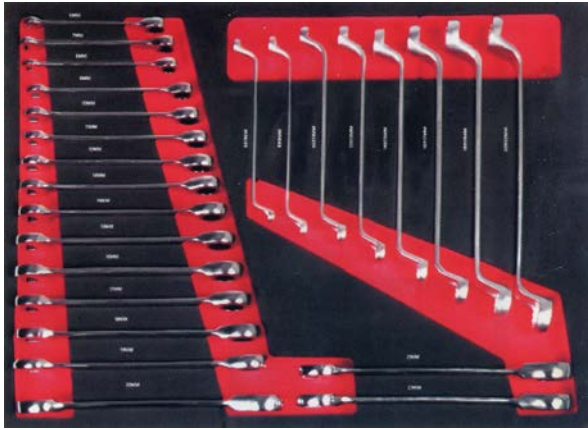

**SET 25PCS**  
**CHIAVI COMBinate A**  
**CRICCHETTO E**  
**CHIAVI POLIGONALI,**

**KIT OF 25PCS**  
**COMBINED RATCHET**  
**WRENCHES AND**  
**POLIGONAL WRENCHES,**

**JUEGO DE 25PCS**  
**LLAVES CRIQUE**  
**COMBINADAS Y LLAVES POLI-**  
**GONALES,**

IL SET INCLUDE:	THE KIT INCLUDES:	EL KIT INCLUYE:
17pcs chiavi combinate a cricchetto 6-7-8-9-10-11-12-13-14-15-16-17- 18-19-20-21-22mm	17pcs combined ratchet wrenches 6-7-8-9-10-11-12-13-14-15-16-17- 18-19-20-21-22mm	17pcs llaves crique combinadas 6-7-8-9-10-11-12-13-14-15-16-17- 18-19-20-21-22mm
8pcs chiavi poligonali 8x9-10x11-12x13-14x15-16x17- 18x19-20x22mm	8pcs poligon wrenches 8x9-10x11-12x13-14x15-16x17- 18x19-20x22mm	8pcs llaves poligonales 8x9-10x11-12x13-14x15-16x17- 18x19-20x22mm



**26PCS**  
**SET CACCIAVITI,**

**26PCS**  
**SCREWDRIVERS KIT,**

**JUEGO DE DESTORNILLADORES**  
**26PCS,**

IL KIT INCLUDE	THE KIT INCLUDES	EL KIT INCLUYE
7pcs cacciaviti a punta piatta, SL6X38, SL8X175, SL3X75, SL6,5X150, SL3,5X75, SL5, 5X100, SL4X100	7pcs flat tips screwdrivers, SL6X38, SL8X175, SL3X75, SL6,5X150, SL3,5X75, SL5,5X100, SL4X100	7pcs destornilladores de punta plana, SL6X38, SL8X175, SL3X75, SL6,5X150, SL3,5X75, SL5,5X100, SL4X100
7pcs cacciaviti a croce PH2X38, PH4X200, PH0X75, PH3X150, PH1X100, PH2X125, PH2X100	7pcs cross-tip screwdrivers PH2X38, PH4X200, PH0X75, PH3X150, PH1X100, PH2X125, PH2X100	7pcs destornilladores en cruz PH2X38, PH4X200, PH0X75, PH3X150, PH1X100, PH2X125, PH2X100
6pcs cacciaviti alto isolamento 6,5X150, 5,5X125, 4X100, 3X75, PH1X100, PH2X100	6pcs high insulation screwdrivers 6,5X150, 5,5X125, 4X100, 3X75, PH1X100, PH2X100	6pcs destornilladores de alto aislamiento 6,5X150, 5,5X125, 4X100, 3X75, PH1X100, PH2X100



**62PCS**  
**CHIAVI ESAGONALI,**  
**LIME E INSERTI,**

**62PCS**  
**HEXAGONAL WRENCHES,**  
**FILES AND INSERTS,**

**62PCS**  
**LLAVES HEXAGONALES,**  
**LIMAS E INSERTOS,**

IL KIT INCLUDE	THE KIT INCLUDES	EL KIT INCLUYE
6pcs chiavi a T hex 2,5X100 - 3X100 - 4X150 - 2X100 6,5X150 - 5X150mm	6pcs hexagonal T-wrenches 2,5X100 - 3X100 - 4X150 - 2X100 6,5X150 - 5X150mm	6pcs llaves hexagonales en T 2,5X100 - 3X100 - 4X150 - 2X100 - 6,5X150 - 5X150mm
2pcs chiavi torx T9, T10, T15, T20, T25, T27, T30, T40	2pcs Torx wrenches T9, T10, T15, T20, T25, T27, T30, T40	2pcs llaves torx T 9, T10, T15, T20, T25, T27, T30, T40
5pcs lime (piatta, mezza tonda, triangolo, quadra, tonda)	5pcs files (flat, half rounded, triangular, square, rounded)	5pcs limas (punta fina, medio redondeado, triangolare, quadrato, redondeado)
9pcs bussola 1/4" 5-6-7-8-9-10-11-12-13mm	9pcs socket wrenches 1/4" 5-6-7-8-9-10-11-12-13mm	9pcs llaves di tubo 1/4" 5-6-7-8-9-10-11-12-13mm
23pcs inserti assortiti (punta a taglio, croce, esagonale)	23pcs assorted inserts (flat tip, cross tip, hexagonal)	23pcs insertos variados (punta fina, punta en cruz, hexagonal)
9pcs chiavi a L esagonali 1,5-2-2,5-3-4-5-6-8-10mm	9pcs hexagonal L-wrenches 1,5-2-2,5-3-4-5-6-8-10mm	9pcs llaves hexagonales en L 1,5-2-2,5-3-4-5-6-8-10mm



**11pcs**  
**PINZE E MARTELLI,**

**11pcs**  
**PLIERS AND HAMMERS,**

**11pcs**  
**ALICATES Y MARTILLOS,**

IL KIT INCLUDE	THE KIT INCLUDES	EL KIT INCLUYE
1pc pinza combinata 200mm	1pc combined pliers 200mm	1pc alicates combinados 200mm
1pc pinza a becchi dritti 200mm	1pc straight nose pliers 200mm	1pc alicates de punta fina 200mm
1pc tronchesi	1pc clippers	1pc tijeras
1pc martello 300gr	1pc hammer 300gr	1pc martillo 300gr
1pc martello in plastica	1pc plastic hammer	1pc martillo de plastico
1pc pinza per lamiera 250mm	1pc plate grip 250mm	1pc pinzas de chapa 250mm
1pc pinza a coccodrillo 250mm	1pc crocodile clip 250mm	1pc pinzas de cocodrilo 250mm
1pc pinza per seeger interni dritta	1pc pliers for internal seegers, straight	1pc alicates para seeger internos, punta fina
1pc pinza per seeger interni a 90°	1pc pliers for internal seegers, 90°	1pc alicates para seeger internos, 90°
1pc pinza per seeger esterni dritta	1pc pliers for external seegers, straight	1pc alicates para seeger externos, punta fina
1pc pinza per seeger esterni a 90°	1pc pliers for external seegers, 90°	1pc alicates para seeger externos, 90°



**Carrello 7 cassetti - 7-drawer trolley - Carro 7 cajones**



<b>ABS TOP</b>	<b>ANTI SHOC PROTECTION</b>		mm 770 A mm 465 B mm 980 C
			mm 790 A mm 470 B mm 850 C

**VUOTO - EMPTY - VACIO**  
Cod. 05.088.55  
**€ 452,00**

**+ KIT BASIC**  
Cod. 05.088.56  
**€ 768,00**

**+ KIT PROFI**  
Cod. 05.088.06  
**€ 973,00**

**NEW!  
2018**

**Carrello 6 cassetti - 6-drawer trolley - Carro 6 cajones**



<b>ABS TOP</b>	<b>ANTI SHOC PROTECTION</b>		mm 780 A mm 460 B mm 970 C
			mm 780 A mm 460 B mm 820 C

**VUOTO - EMPTY - VACIO**  
Cod. 05.088.82  
**€ 421,00**

**+ KIT BASIC**  
Cod. 05.088.84  
**€ 737,00**

**+ KIT PROFI**  
Cod. 05.088.85  
**€ 942,00**

**HOT!**

**Carrello 7 cassetti - 7-drawer trolley - Carro 7 cajones**



			<b>ABS TOP</b>
			mm 678 A mm 460 B mm 1030 C
			mm 740 A mm 520 B mm 900 C

**VUOTO - EMPTY - VACIO**  
Cod. 05.088.44  
**€ 379,00**

**+ KIT BASIC**  
Cod. 05.088.53  
**€ 695,00**

**+ KIT PROFI**  
Cod. 05.088.62  
**€ 900,00**





**HOT!**

Cod. 05.088.40

€ 190,00

**5-drawers roll cab (empty)**  
**Carro 5 cajones (vacío)**  
**Carrello 5 cassetti (vuoto)**



GUIDA SU CUSCINETTI  
 BALL BEARING SLIDES  
 GUIA CON COJINETES DE BOLAS

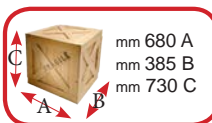

**NEW!  
2018**

**CARRELLO DI SERVIZIO CON CASSETTIERA SUPERIORE**  
**TOOL CABINET WITH UPPER CHEST OF DRAWERS**  
**CARRO DE HERRAMIENTAS CON COFRE SUPERIOR DE CAJONES**

**PRIMO PREZZO  
FIRST PRICE  
PRIMER PRECIO**

Cod. 05.088.80

€ 178,00



**DATI TECNICI:**

- **SALVA SPAZIO!  
LA CASSETTIERA È  
CONTENUTA NEL CARRELLO  
INFERIORE**
- Casettiera superiore:  
600 x 255 x 345 mm
- Dimensioni cassetti:  
3 x 151 x 226 x 37 mm  
2 x 511 x 226 x 37 mm  
1 x 511 x 304 x 86 mm
- Carrello inferiore:  
616 x 330 x 750 mm
- Dimensioni cassetti carrello:  
2 x 511 x 304 x 85 mm
- 4 ruote piroettanti, 2 freni
- 8 ganci laterali per utensili
- Dimensioni imballo:  
Casettiera superiore:  
615 x 270 x 360 mm  
Carrello:  
700 x 270 x 360 mm
- Peso lordo/netto: 23/22kg

**TECHNICAL FEATURES:**

- **SPACE SAVING!  
THE CHEST OF DRAWERS  
IS INCLUDED IN THE ROLL  
CAB BENEATH**
- Top chest:  
600 x 255 x 345 mm
- Top chest drawers:  
3 x 151 x 226 x 37 mm  
2 x 511 x 226 x 37 mm  
1 x 511 x 304 x 86 mm
- Roller cabinet:  
616 x 330 x 750 mm
- Roller cabinet drawers:  
2 x 511 x 304 x 85 mm
- 4 wheels with 2 brakes
- 8 small side metal hooks
- Packaging dimensions:  
Top chest:  
615 x 270 x 360 mm  
Roller cabinet:  
700 x 270 x 360 mm
- Gross/net weight: 23/22kg

**DATOS TÉCNICOS:**

- **AHORRO DE ESPACIO!  
LA CAJONERA ESTÁ  
INCLUIDA EN EL CARRITO  
POR DEBAJO**
- Cómoda superior:  
600 x 255 x 345 mm
- Dimensiones cajones:  
3 x 151 x 226 x 37 mm  
2 x 511 x 226 x 37 mm  
1 x 511 x 304 x 86 mm
- Carro inferior:  
616 x 330 x 750 mm
- Dimensiones cajones carro:  
2 x 511 x 304 x 85 mm
- 4 ruedas giratorias, 2 frenos
- 8 ganchos laterales para  
herramientas
- Dimensiones del embalaje:  
Cómoda superior:  
615 x 270 x 360 mm  
Carro inferior:  
700 x 270 x 360 mm
- Peso neto/bruto: 23/22kg

Nuovi kit utensili da esposizione in morbida spugna bicolore  
 New tools exhibition kits in soft two-coloured sponge  
 Nuevos kit de exposición de herramientas en esponja blanda de dos colores

**KIT PROFÍ**  
193 pcs

**Cod. 05.088.47**

**€ 521,00**

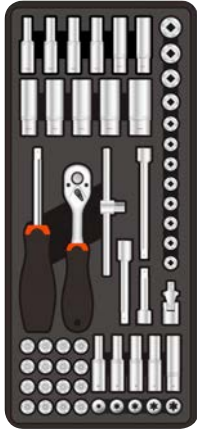

**Cod. 05.090.30**

**€ 50,00**

Profí Basic

● ●

Set 54pcs bussole/accessori 1/4"  
 Kit of 54pcs socket wrenches/accessories 1/4"  
 Juego de 54pcs llaves de tubo/accessorios 1/4"

Materiale CR-V  
 Material CR-V  
 Material CR-V

**IL SET CONTIENE - THE KIT INCLUDES - EL KIT INCLUDE**

Bussole 1/4"	Bussole 1/4" lunghe	Bussole 1/4" torx E	Barre estensione 1/4"	Inseriti 1/4"
Socket wrenches 1/4"	Long socket wrenches 1/4"	Torx socket wrenches 1/4"E	Extension bars 1/4"	Inserts 1/4"
Llaves de tubo 1/4"	Llaves de tubos largos 1/4"	Llaves de tubo torx 1/4"E	Barros de extension 1/4"	PH1,2 - PZ1,2 SL 4,5 - 5
4 - 4,5 - 5 - 6	4 - 5 - 6 - 7 - 8	4 - 5 - 6 - 7 - 8	50-75-100mm	H 3, 4, 5, 6 T8, T10, T15, T20, T25, T30
7 - 8 - 9 - 10 - 11 12 - 13mm	9 - 10 - 11 - 12 13 - 14mm			

**KIT BASIC**  
154 pcs

**Cod. 05.088.48**

**€ 316,00**



**Cod. 05.090.34**

**€ 38,40**

Profí Basic

● ●

Kit 8pcs chiavi poligonali  
 Kit 8pcs polygonal wrenches  
 Juego de 8pcs llaves poligonales

6x7, 8x9, 10x11, 12x13, 14x15, 16x17, 18x19, 20x22mm

Materiale CR-V  
 Material CR-V  
 Material CR-V



**Cod. 05.090.31**

**€ 54,20**

Profí Basic

● ●

Kit 19pcs bussole/accessori 1/2"  
 Kit 19pcs socket wrenches/accessories 1/2"  
 Juego de 19pcs llaves de tubo/accessorios 1/2"

Materiale CR-V  
 Material CR-V  
 Material CR-V

**IL SET CONTIENE - THE KIT INCLUDES - EL KIT INCLUDE**

Bussole 1/2"	Barre estensione 1/2"	Giunto girevole 1/2"	Barra scroevole 1/2"	Cricchetto 1/2"
Socket wrenches 1/2"	Extension bars 1/2"	Swivel joint 1/2"	Sliding bar 1/2"	Ratchet 1/2"
Llaves de tubo 1/2"	Barros de extension 1/2"	Junta rotatoria 1/2"	Barra corredera 1/2"	Carroca 1/2"
10 - 11 - 12 - 13	125-150mm		25mm	
14 - 15 - 16 - 17				
18 - 19 - 21 - 22				
23 - 24mm				



**Cod. 05.090.35**

**€ 28,60**

Profí Basic

● —

Set 6pcs chiavi per tubi freni  
 Kit 6pcs wrenches for brake hoses  
 Juego de 6pcs de llaves para mangueras de frenos

6\*8 - 10\*12 - 13\*14 - 15\*17 - 19\*21 - 22\*24mm

Materiale CR-V  
 Material CR-V  
 Material CR-V



**Cod. 05.090.32**

**€ 43,80**

Profí Basic

● —

Kit 16pcs bussole lunghe 1/2"  
 Kit 16pcs long socket wrenches 1/2"  
 Juego de 16pcs llaves de tubo largas 1/2"

Materiale CR-V  
 Material CR-V  
 Material CR-V

**IL SET CONTIENE - THE KIT INCLUDES - EL KIT INCLUDE**

Chiavi esagonali 1/2"	Chiavi torx 1/2"
Hexagonal wrenches 1/2"	Torx wrenches 1/2"
Llaves hexagonales 1/2"	Llaves torx 1/2"
1/2" 8-9-10-11-12-13mm	E10, E11, E12, E14, E16, E18, E20, E22, E24



**Cod. 05.090.36**

**€ 26,50**

Profí Basic

● ●

Kit 34pcs chiavi esagonali a L  
 Kit 34pcs hexagonal L-wrenches  
 Juego de 34pcs llaves hexagonales en L

**IL SET CONTIENE - THE KIT INCLUDES - EL KIT INCLUDE**

9pcs chiavi esagonali	9pcs chiavi esagonali SAE	8pcs chiavi torx	8pcs chiavi esagonali SAE
1,5 - 2 - 2,5 3 - 4 - 5 6 - 8 - 10mm	1/16, 5/64, 3/32, 1/8, 5/32, 3/16, 1/4, 5/16, 3/8	T9, T10, T15, T20, T25, T27, T30, T40	1/16, 5/64, 3/32, 1/8, 5/32, 3/16, 7/32, 1/4"



**Cod. 05.090.33**

**€ 53,80**

Profí Basic

● ●

Kit 17pcs chiavi combinate  
 Kit 17pcs combined wrenches  
 Juego de 17pcs llaves combinadas

Materiale CR-V  
 Material CR-V  
 Material CR-V

6-7-8-9-10-11-12-13-14-15-16-17-18-19-20-21-22mm



**Cod. 05.090.37**

**€ 16,40**

Profí Basic

● ●

Kit 7pcs cacciaviti torx  
 Kit 7pcs torx screwdrivers  
 Juego de 7pcs destornilladores torx

**IL SET CONTIENE - THE KIT INCLUDES - EL KIT INCLUDE**

T10/75, T15/100, T20/100, T25/100, T30/100, T40/100



Cod. 05.090.38

€16,<sup>40</sup>

Profi

Basic

Kit 8pcs cacciaviti a taglio e croce  
Kit 8pcs screwdrivers with flat and cross tip  
Juego de 8pcs destornilladores con punta plana y en cruz

Materiale CR-V  
Material CR-V  
Material CR-V

IL SET CONTIENE - THE KIT INCLUDES - EL KIT INCLUDE

6,5x1,2x38	5,5x1x100	2x38	2x100
4x08x100	6,5x1,2x150	1x100	3x150



Cod. 05.090.42

€27,<sup>30</sup>

Profi

Basic

2 pinze L = 250mm  
2 pliers L = 250mm  
2 alicates L = 250mm

Materiale CR-V  
Material CR-V  
Material CR-V

IL SET CONTIENE - THE KIT INCLUDES - EL KIT INCLUDE

Pinza a coccodrillo L = 250mm	Crocodile clips L = 250mm	Pinza de crocodilo L = 250mm
Pinza per lamiera L = 250mm	Plate grip L = 250mm	Pinzas de chapa L = 250mm2



Cod. 05.090.39

€47,<sup>80</sup>

Profi

Basic

Kit 9pcs scalpelli  
Kit 9pcs chisels  
Juego de 9pcs cinceles

IL SET CONTIENE - THE KIT INCLUDES - EL KIT INCLUDE

3pcs punta piatta	2pcs punta fina	2pcs punta conica	1pc punta triangolare
3pcs flat head	2pcs pin head	2pcs taper punch	1pc triangular head
3pcs punta plana	2pcs punta fina	2pcs punta conica	1pc punta triangolar
19x12x180	8x12x180	6x10x180	6x10x180
12x10x160	10x12x180	8x12x180	
16x12x175			



Cod. 05.090.43

€24,<sup>60</sup>

Profi

Basic

Kit 4pcs pinze seeger  
Kit 4pcs pliers for seeger  
Juego de 4pcs alicates para seeger

Materiale CR-V  
Material CR-V  
Material CR-V

IL SET CONTIENE - THE KIT INCLUDES - EL KIT INCLUDE

1pc dritta per seeger interni	1pc straight for internal seegers	1pc recta para seeger internos
1pc angolare per seeger interni	1pc bent for internal seegers	1pc curvada para seeger internos
1pc dritta per seeger esterni	1pc straight for external seegers	1pc recta para seeger externos
1pc angolare per seeger esterni	1pc bent for external seegers	1pc curvada para seeger externos



Cod. 05.090.40

€22,<sup>80</sup>

Profi

Basic

Kit 5pcs lime 8"  
Kit 5pcs files 8"  
Juego de 5pcs limas 8"

IL SET CONTIENE - THE KIT INCLUDES - EL KIT INCLUDE

1 lima piana,	1 flat file,	1 lima fina,
1 lima mezza tonda,	1 half rounded file,	1 lima media redondata,
1 lima triangolare,	1 triangular file,	1 lima triangolar,
1 lima quadra,	1 square file,	1 lima cuadrada,
1 lima tonda	1 rounded file	1 lima redondata



Cod. 05.090.44

€37,<sup>40</sup>

Profi

Basic

2pcs martelli  
2pcs hammers  
2pcs martillos

IL SET CONTIENE - THE KIT INCLUDES - EL KIT INCLUDE

1pc martello da 300gr	1pc 300gr hammer	1pc martillo de 300gr
1pc mazzuolo in plastica	1pc plastic maller	1pc mazo de plastico

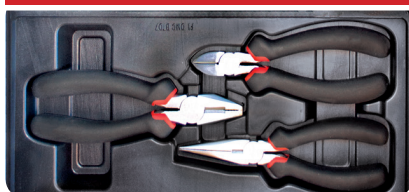

Cod. 05.090.41

€33,<sup>00</sup>

Profi

Basic

Kit 3pcs pinze  
Kit 3pcs pliers  
Juego de 3pcs alicates

Materiale CR-V  
Material CR-V  
Material CR-V

IL SET CONTIENE - THE KIT INCLUDES - EL KIT INCLUDE

Pinza combinata 200mm	Combined pliers 200mm	Alicates combinados 200mm
Pinza a becchi dritti 200mm	Straight nose pliers 200mm	Alicates de punta fina 200mm
Tronchisi	Clippers	Tijeras

Disponibili ricambi per tutti i kit

Spare parts available for both kits

Repuestos disponibles para los dos kit

Cod. 05.090.29B

€115,<sup>00</sup>

CON TERMOFORMATO / WITH THERMOFORMED BASE / CON BASE TERMOFORMADA

Cod. 05.090.29

€113,<sup>00</sup>

SENZA TERMOFORMATO / WITHOUT THERMOFORMED BASE / SIN BASE TERMOFORMADA

Cod. 05.090.26

€49,<sup>50</sup>

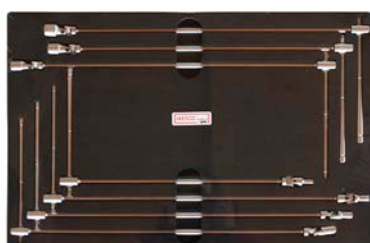

Kit 7 chiavi a T snodate

7 T-bended wrenches kit

Juego de llaves de cubo a "T"

(7, 8, 10, 11, 13, 15, 17 mm)

Kit 14 chiavi a pipa

14 double ended offset hexagon wrenches kit

Juego de 14 llaves extensibles hexagonales



NEW!  
2018



Cod. 05.088.81

€ 84,00

TAVOLO DA LAVORO  
CON PANNELLO PORTA ATTREZZI E CASSETTO  
WORK BENCH WITH THE BOARD  
FOR TOOL STORAGE AND DRAWER  
BANCO DE TRABAJO  
CON TABLERO PORTA HERRAMIENTAS Y CAJÓN

Dati tecnici:

- Dimensioni: 120 x 55 x 150 cm
- Dimensioni imballo: 124 x 58 x 7 cm
- Peso lordo/netto: 27/25kg

Technical features:

- Overall size: 120 x 55 x 150 cm
- Packaging dimensions: 124 x 58 x 7 cm
- Gross/net weight: 27/25kg

Datos técnicos:

- Tamaño global: 120 x 55 x 150 cm
- Dimensiones de embalaje: 124 x 58 x 7 cm
- Peso neto/bruto: 27/25kg

Cod. 05.088.86

€ 34,00

KIT 30 VASCHETTE PORTAMINUTERIE  
30 STORAGE BINS FOR SMALL PARTS  
JUEGO DE 30 BANDEJAS PARA PIEZAS PEQUEÑAS



NEW!  
2018

Dati tecnici:

- Pannello di 64x38cm in plastica, da appendere a muro
- 12 vaschette blu da 16,5 x 10 x 7,3 cm
- 18 vaschette gialle da 9,5 x 10 x 5 cm

Technical features:

- Wall mounted panel board: 64x38cm
- 12 blue bins: 16,5x10x7,3cm
- 18 yellow bins: 9,5x10x9cm

Datos técnicos:

- Panel montado en la pared: 64x38cm
- 12 contenedores azules: 16,5x10x7,3cm
- 18 cont. amarillos: 9,5x10x9cm

CASSETTIERE ORGANIZER

Cod. 05.088.70

€ 20,50



CASSETTA 24+2 SCOMPARTIMENTI  
CASE WITH 24+2 COMPARTMENTS  
CAJA CON 24 + 2 COMPARTIMIENTOS

misure/ dimensions/ dimensiones:	45x8x32cm
24 scompartimenti da / 24 compartments / 24 compartimentos	8 x 6,5cm
2 scompartimenti da / 2 compartments / 2 compartimentos	15 x 7,5cm

MULTI-COMPARTMENT ORGANIZERS

ORGANIZADORES CON COMPARTIMIENTOS MÚLTIPLES

Cod. 05.088.69

€ 15,00



CASSETTA 18+1 SCOMPARTIMENTI  
CASE WITH 18+1 COMPARTMENTS  
CAJA CON 18 + 1 COMPARTIMIENTOS

misure/ dimensions/ dimensiones:	36x6,5x28cm
18 scompartimenti da / 18 compartments / 18 compartimentos	6 x 7cm
1 scompartimento da / 1 compartment / 2 compartimento	35 x 7cm

Cod. 05.083.03

€ 49,00



SGABELLO REGOLABILE  
CON PORTAUTENSILI

ADJUSTABLE STOOL WITH  
TOOL-HOLDER

TABURETE AJUSTABLE CON  
PORTAHERRAMIENTAS

Dati tecnici:  
Peso: 4,5Kg  
Altezza max.: 540mm  
Altezza min.: 420mm  
Dimensioni imballo:  
40x40x15cm  
Portata: 130Kg

Technical data:  
Weight: 4.5 kg  
Max. height.: 540mm  
Min. height: 420mm  
Package dimensions:  
40x40x15cm  
Capacity: 130Kg

Datos técnicos:  
Peso: 4,5Kg  
Longitud max.: 540mm  
Longitud min.: 420mm  
Dimensiones del emba-  
laje: 40x40x15cm  
Capacidad: 130Kg

Cod. 05.083.02

€ 32,50

SGABELLO FISSO CON QUATTRO RUOTE E PORTA UTENSILI  
STOOL WITH FOUR WHEELS AND TOOLS-HOLDER  
TABURETE CON CUATRO RUEDAS Y PORTA-HERRAMIENTAS



Weight / Peso:  
3,8kgs

Dimensions:  
Dimensiones:  
Dimensioni:  
360x365x365mm

TAVOLI DA LAVORO - WORK BENCHES - BANCOS DE TRABAJO

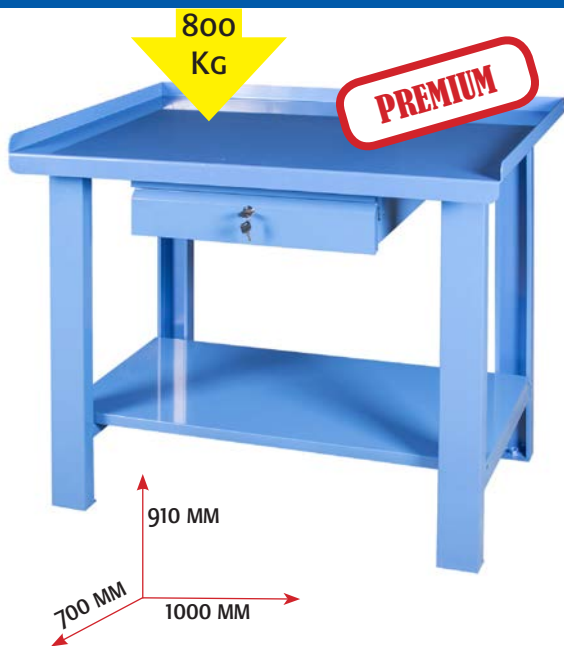

Cod. 05.088.72

€ 271,00

1mt, 1 cassetto, 1 ripiano inferiore.  
Lamiere piano appoggio da 30/10 altezza bordi 40mm, cassetto con guida su cuscinetti e chiave. In kit di montaggio.

1mt, 1 drawer, 1 lower rack.  
Sheet metal worktop thickness 30/10, height of edges 40mm, drawer with guide bearings and key. Assembly kit.

1mt, 1 cajón, 1 estante inferior.  
Espesor de la plancha de metal de trabajo de 30/10, altura de los bordes 40mm, cajon con cojinetes de guía y clave.

Dimensioni imballo  
Package dimension  
Dimensiones embalaje



Kg  
42,5/45



Cod. 05.088.73

€ 360,00

1.6mt, 1 cassetto, 1 ripiano inferiore.  
Lamiere piano appoggio da 30/10 altezza bordi 40mm, cassetto con guida su cuscinetti e chiave. In kit di montaggio

1.6mt, 1 drawer, 1 lower rack.  
Sheet metal worktop thickness 30/10, height of edges 40mm, drawer with guide bearings and key. Package dimensions

1.6mt, 1 cajón, 1 estante inferior.  
Espesor de la plancha de metal de trabajo de 30/10, altura de los bordes 40mm, cajon con cojinetes de guía y clave  
Kit de montaje

Dimensioni imballo  
Package dimension  
Dimensiones embalaje

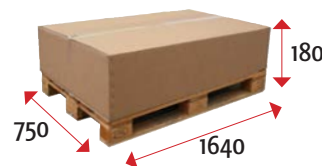

Kg  
56/59



Cod. 05.088.74

€ 490,00

Kit de montaje.  
2mt, 2 cassetti, 1 ripiano inferiore, 6 gambe.  
Lamiere piano appoggio da 30/10 altezza bordi 40mm,  
2 cassetti con guida su cuscinetti e chiave  
In kit di montaggio

2mt, 2 drawers, 1 lower rack, 6 legs.  
Sheet metal worktop thickness 30/10, height of edges 40mm,  
2 drawers with guide bearings and key  
Assembly kit

2mt, 2 cajones, 1 estante inferior, 6 patas.  
Espesor de la plancha de metal de trabajo de 30/10,  
altura de los bordes 40mm, 2 cajones con cojinetes de guía y clave  
Kit de montaje

Dimensioni imballo  
Package dimension  
Dimensiones embalaje



Kg  
81/85



Cod. 05.088.75

€ 407,<sup>00</sup>

Tavolo per lo smontaggio di cambi dotato di piano inclinato e fori di scolo su serbatoio di raccolta olio. Dotato di 4 ruote (2 con freno) e cassetto porta attrezzi

Table for dismantling gearboxes with inclined worktop and drain holes on the oil collecting tank. Equipped with 4 wheels (2 with brake) and drawer for tools.

Mesa inclinada para el desmantelamiento de las cajas de cambios con agujeros de drenaje y en depósito de recogida del aceite. Equipado con 4 ruedas (2 con freno) y cajón para las herramientas.

Dimensioni imballo  
Package dimension  
Dimensiones embalaje

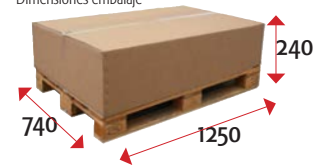
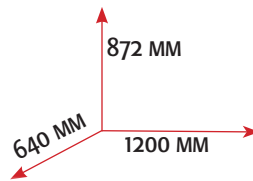

Kg  
56,5/62

**Serie cricchi a bottiglia**

**Hydraulic bottle jacks**

**Gatos de botella hidraulicos**



Codice Code Codigo	Capacità Capacity Capacidad	Altezza min. Min. height Altura min.	Alzata Riser Alzamiento	Regolazione altezza Height adjustment Ajuste altura	Peso netto Net weight Peso neto	
05.084.12	6 TONS	200	125	60	4.60	€ 24, <sup>00</sup>
05.084.13	10 TONS	200	140	60	6.20	€ 33, <sup>00</sup>
05.084.14	16 TONS	225	140	60	9.20	€ 46, <sup>00</sup>
05.084.16	20 TONS	235	145	60	11.70	€ 56, <sup>00</sup>
05.084.15	32 TONS	255	150	--	18.00	€ 108, <sup>00</sup>



Cod. 05.084.07

€ 157,<sup>00</sup>

**CRICCO A BOTTIGLIA A COMANDO PNEUMATICO (20TON)**

IDEALE COME KIT SOCCORSO PER AUTOCARRI, PUO' ESSERE USATO ANCHE MANUALMENTE CON LEVA

**BOTTLE JACK WITH PNEUMATIC FUNCTIONING (20TON)**

IDEAL AS AID KIT FOR TRUCKS, IT MAY BE USED ALSO BY HAND WITH A LEVER

**GATO DE BOTELLA CON FUNCIONAMIENTO NEUMÁTICO (20 TON)**

IDEAL COMO KIT DE AYUDA PARA CAMIONES, PUEDE SER UTILIZADO TAMBIÉN POR MANO CON UNA PALANCA

Altezza min.: 267mm  
Altezza max.: 515mm  
Dim. Imballo: 290x185x280mm  
Peso netto/lordo: 17,7/19kgs

Min. height: 267 mm  
Max. height: 515mm  
Packaging dim.: 290x185x280mm  
Net/gross weight: 17,7/19kgs

Altura min.: 267 mm  
Altura max.: 515mm  
Dim. embalaje: 290x185x280mm  
Peso neto/bruto: 17,7/19 kgs

Cod. 05.084.17 mod. 35 ton

€ 232,<sup>00</sup>



Cod. 05.087.06

€ 157,00

HOT!



**CARRELLO SPOSTAMENTO VETTURE INCIDENTATE  
HYDRAULIC VEHICLE POSITIONING JACK  
SOPORTE MOVIL PARA COCHES AVERIADOS**

Capacità: 600 kg	Capacity: 600 kg	Capacidad: 600Kgs
Max/Min apertura: 650÷300mm	Max/min width: 650÷300mm	Ancho Max/Min: 650÷300Mm
Peso: 19 kg	Weight: 19 kg	Peso: 19Kgs

Cod. 05.084.03

€ 389,00

**CRICCO A CARRELLO, 2 T, A 6 RUOTE  
LOW PROFILE 2 TONS JACK, 6 WHEELS  
GATO CON 6 RUEDAS, 2 T**

Portata/capacity/ Capacidad:	2 TONS
Min. altezza/height/ Altura min.:	76 MM
Max. altezza/height/ Altura max.:	510 MM
Dimensioni/dimensions/ Dimensiones:	1006x365x136MM
Peso/ weight/ Peso:	42 KG



Ruote in Nylon  
Nylon wheels  
Ruedas de nylon

Pratico vassoio porta attrezzi  
Practical tray for carrying tools  
Bandeja práctica para portar herramientas

Ruote gemellate di serie in Nylon  
Standard double front wheel in nylon  
Rueda delantera doble estándar en nylon

Tampone in gomma  
Rubber pad for the saddle  
Pastilla de goma

Cod. 05.084.01

€ 183,00

**CRICCO A CARRELLO 2,5 T  
2,5 TONS TROLLEY JACK  
GATO CON RUEDAS 2,5 T**

Portata/capacity/ Capacidad:	2,5 tons
Min. altezza/height/ Altura min.:	85 mm
Max. altezza/height/ Altura max.:	455 mm
Ruote in nylon/piattello in gomma nylon wheels/ rubber pad Ruedas de nylon/Pastilla de goma	
Dimensioni/dimensions/ Dimensiones:	640x342x174mm
Peso/ weight/ Peso:	34,8 kg



HOT!



Ruote in Nylon  
Nylon wheels  
Ruedas de nylon

Cod. 05.084.02

€ 258,00

**CRICCO A CARRELLO 3 T, DOPPIO PISTONE  
3 TONS TROLLEY JACK, DOUBLE PISTON  
GATO CON RUEDAS 3 T, PISTON DOBLE**

Portata - Capacity - Capacidad:	3 TONS
Min. altezza - Min. height - Altura min.:	95 MM
Max. altezza - Max height - Altura max.:	455 MM
Doppio pistone - Double piston - Piston doble	✓
Ruote in nylon - nylon wheels - Ruedas de nylon	✓
Piattello in gomma - rubber pad - Pastilla de goma	✓
Dimensioni: Dimensions: Dimensiones:	780x366x160MM
Peso: Weight: Peso:	46 KG

Ruote in Nylon  
Nylon wheels  
Ruedas de nylon



**NEW!  
2018**



Cod. 05.084.22

€ 472,00

CRICCO A CARRELLO 3 IN ALLUMINIO  
3 TONS TROLLEY JACK, FULL ALUMINIUM  
GATO CON RUEDAS 3 T DE ALUMINIO

**Dati tecnici:**

- Maniglia di trasporto
- Doppio pistone per sollevamento veloce
- Profilo basso
- Capacità: 3 ton
- Altezza min: 98mm
- Altezza max: 480mm
- Dimensioni prodotto: 730x320x180mm
- Dimensioni imballo: 785x380x215mm
- Peso netto/Peso lordo: 24,4/26,5kg

**Technical features:**

- Easy carrying
- Fast lifting dual pump
- Low profile
- Capacity: 3 tons
- Min. Height: 98mm
- Max. Height: 480mm
- Product size: 730x320x180mm
- Package size: 785x380x215mm
- Net Weight/Gross Weight: 24,4/26,5kg

**Datos técnicos:**

- Transporte comodo
- Bomba doble para elevacion rapida
- Perfil bajo
- Capacidad: 3 ton
- Altura min.: 98mm
- Altura max.: 480mm
- Tamaño producto: 730x320x180mm
- Tamaño embalaje: 785x380x215mm
- Peso neto/Peso bruto: 24,4/26,5kg

Cod. 05.084.19

€ 352,00

SOLLEVATORE DA 2 TON CON 2 AIR BAG  
2 TONS DOUBLE BAG AIR JACK  
LEVANTADOR DE 2 TON CON 2 AIR BAG

**NEW!  
2018**



**Dati tecnici:**

- Capacità: 2 ton
- Max. pressione di lavoro: 10 bar
- Altezza min: 115 mm
- Altezza max: 280 mm
- Tempo di sollevamento 5sec
- Dimensioni imballo: 510x480x160mm
- Peso netto/Peso lordo: 19/20kg

**Technical features:**

- Capacity: 2 ton
- Max. working pressure: 10 bar
- Min. height: 115 mm
- Max. height: 280 mm
- Lifting time: 5sec
- Package size: 510x480x160mm
- Peso netto/Peso lordo: 19/20kg

**Datos técnicos:**

- Capacidad: 2 ton
- Max. presión de trabajo: 10 bar
- **Altura min.: 115 mm**
- **Altura max.: 280 mm**
- Tiempo de elevación: 5sec
- Tamaño embalaje: 510x480x160mm
- Peso neto/Peso bruto: 19/20kg

Cod. 05.084.23

€ 373,00

SOLLEVATORE DA 2 TON CON 3 AIR BAG  
2 TONS TRIPLE BAG AIR JACK  
LEVANTADOR DE 2 TON CON 3 AIR BAG

**NEW!  
2018**



**Dati tecnici:**

- Capacità: 2 ton
- Max. pressione di lavoro: 10 bar
- **Altezza min: 145mm**
- **Altezza max: 400mm**
- Tempo di sollevamento 5sec
- Dimensioni imballo: 510x480x160mm
- Peso netto/Peso lordo: 19/20kg

**Technical features:**

- Capacity: 2 ton
- Max. working pressure: 10 bar
- **Min. height: 145mm**
- **Max. height: 400mm**
- Lifting time: 5sec
- Package size: 510x480x160mm
- Peso netto/Peso lordo: 19/20kg

**Datos técnicos:**

- Capacidad: 2 ton
- Max. presión de trabajo: 10 bar
- **Altura min.: 145mm**
- **Altura max.: 400mm**
- Tiempo de elevación: 5sec
- Tamaño embalaje: 510x480x160mm
- Peso neto/Peso bruto: 19/20kg

Cod. 05.084.06

€ 360,00



**CRICCO IDRAULICO A CARRELLO DA 2TON A GRANDE ALZATA**  
IDONEO PER LAVORI DI CARROZZERIA IN SPAZI PRIVI DI ALTRO TIPO DI SOLLEVATORI IDRAULICI

**HAND HYDRAULIC JACK 2TONS GREAT ELEVATION**  
SUITABLE FOR BODY SHOP'S WORKS WHERE THERE IS NOT ANY OTHER KIND OF HYDRAULIC LIFTERS

**GATO HIDRÁULICO DE MANO DE 2 TONELADAS**  
**CON ELEVACIÓN SUPERIOR**  
CONVENIENTE PARA LOS TRABAJOS EN TALLERES DE CHAPA Y PINTURA DONDE NO HAY CUALQUIER OTRO TIPO DE ELEVADOR HIDRAULICO



Altezza max: 800mm  
Altezza min: 140mm  
Ruote in nylon  
Piatto in gomma  
Portata max: 2 ton  
Dimensioni: 1184x435x140mm  
Dimensioni imballo: 1260x470x210  
Peso netto/lordo: 58/64kgs

Max height: 800 mm  
Minimum height: 140mm  
Nylon wheels  
Rubber plate  
Max Capacity: 2 tons  
Dimensions: 1184x435x140mm  
Package dimensions: 1260x470x210  
Net/gross weight: 58/64kgs

Altura máxima: 800 mm  
Altura mínima: 140 mm  
Ruedas de nylon  
Placa de goma  
Capacidad max: 2 ton  
Dimensiones: 1184x435x140mm  
Dimensiones embalaje: 1260x470x210  
Peso bruto/neto: 58/64kgs

Cod. 05.085.01

€ 46,00



**COPPIA DI CAVALLETTI DA 3T**  
**COUPLE OF 3T**  
**JACK STANDS**  
**COUPLE DE PYLONES DE 3T**  
**PAAR VON 3 T STÜTZBÖCKEN GATOS DE 3T**

Altezza max/min: Max/min height: Hauteur max/min: Max./min. Höhe: Altura max/min: **428/298mm**  
Peso: Weight: Poids: Gewicht: Peso: **7,5 kg**  
Scatola imballo: Packaging box: Boite emballage: Packungskarton: Caja embalaje: **1**

Cod. 05.085.00

€ 64,00



**COPPIA DI CAVALLETTI DA 6T**  
**COUPLE OF 6T JACK STANDS**  
**COUPLE DE PYLONES DE 6T**  
**PAAR VON 6T STÜTZBÖCKEN**  
**GATOS DE 6T**

Altezza max/min: Max/min height: Hauteur max/min: Max./min. Höhe: Altura max/min: **610/400mm**  
Peso: Weight: Poids: Gewicht: Peso: **14,6 kg**  
Scatola imballo: Packaging box: Boite emballage: Packungskarton: Caja embalaje: **1**

LOGISTICA DI MAGAZZINO / WAREHOUSE LOGISTICS / LOGÍSTICA DE ALMACÉN

200  
Kg

Cod. 05.088.76

€ 190,00



Carrello in acciaio verniciato (uso industriale)  
2 ruote fisse  
2 piroettanti Ø125mm con freno  
tappeti in gomma antiolio  
portata 200kgs  
in kit di montaggio

Trolley in painted steel (industrial use)  
2 Fixed wheels  
2 pivoting 125mm diameter with brake  
Anti-oil rubber mats  
Capacity 200kgs  
In mounting kit

Carro en acero pintado (uso industrial)  
2 ruedas fijas  
2 ruedas giratorias de 125 mm de diámetro con freno  
alfombras de goma anti-aceite  
Capacidad 200kgs  
En Kit de montaje

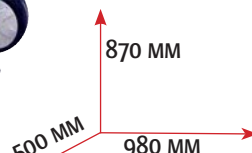

Dimensioni imballo  
Package dimension  
Dimensiones embalaje



Kg  
35/37.5



Cod. 05.088.61

€ 65,00



**Carrello sposta fusti/gomme con maniglia**

**Cart for moving barrels tires equipped with handle**

**Carrito para mover barriles /neumáticos equipado con manija**

Suitable for barrels up to 200lt  
Apropiado para barriles hasta 200lt  
Idoneo per fusti fino a 200lt

4 wheels / 4 ruedas / 4 ruote: 76mm Ø

Packaging dimensions: 73x73x15cm  
Dimensiones del embalaje: 73x73x15cm  
Dimensioni imballo: 73x73x15cm

Weight: Peso: 11kgs

Cod. 05.088.25

€ 54,00



Cod. 05.088.03

€ 39,90



Cod. 05.088.17

€ 166,00



Cod. 05.088.02

€ 80,00

Cod. 05.088.71

€ 90,00



Cod. 05.088.79

€ 49,70

**Ruote in poliuretano piene**  
**Solid polyurethane wheels**  
**Ruedas de poliuretano sólido**



Descrizione Description	Codice Code	Materiale Material	Portata Capacity	Dimensioni Dimensions	Peso Weight	Ruote Wheels
Carrello multiuso 70 kg Multi-purpose trolley 70 kg	05.088.03	Acciaio Steel	70 kg	725x430x60mm	11kg	Ø150mm
Carrello multiuso 180 kg Multi-purpose trolley 180 kg	05.088.17	Alluminio Aluminum	180 kg	605x615x1270mm	11,5kg	Ø200mm
Carrello a 2 ruote 2-wheel hand truck	05.088.79	Acciaio Steel	200 kg	480x480x1190	9 kg	Ø260mm gomma piena / full rubber
Piattaforma mobile Movable platform	05.088.25	Acciaio Steel	100 kg	730x475x835mm	8,1kg	Ø100mm
Carrello 6 ruotei 6 wheels trolley	05.088.71	Acciaio Steel	200 kg	620x550x1200mm	16 kg	Ø 150mm
Carrello 3 piani pesante Heavy trolley with 3 shelves	05.088.02	Acciaio Steel	100 kg	765x365x815mm	20kg	Ø100mm + 2 freni/ brakes



Cod. 05.085.11

€ 125,00

**DISPOSITIVO DI TRASPORTO FUSTI OLIO FINO A 350KGS  
DEVICE FOR TRANSPORTING OIL DRUMS UP TO 350KGS**

**DISPOSITIVO PARA EL TRANSPORTE DE BARRILES DE ACEITE HASTA 350KGS**

Per il trasporto facile e sicuro di fusti da 210lt; è utilizzabile con gru e/o carrelli elevatori da officina

- Per il sollevamento di fusti da 210 litri costruiti interamente in acciaio;
- Sollevamento agevole con gru da officina o carrello elevatore
- Movimento e gestisce facilmente fusti d'acciaio aperti o chiusi;
- Consente un rapido, delicato carico in più livelli e mantiene il fusto in posizione verticale durante il sollevamento, riducendo rovesciamenti di contenuto e rischio di lesioni

Capacità di carico: 350kgs  
Peso netto/lordo: 9,5/11,5kgs  
Dimensioni imballo: 490x260x210mm

For an easy and safe transportation of 210lt drums; it can be used with cranes or forklift trucks for mechanic garages

- For lifting 210 liter steel drum, all-steel construction;
- It works easily with workshop cranes or forklifts
- It moves and handles both open and closed steel drums
- It allows a quick, gentle loading into overpacks and keeps drums upright during lift, reducing spills and the risk of injuries

Load capacity: 350kgs  
Net/gross weight: 9,5/11,5kgs  
Packing dimensions: 490x260x210mm

Para un transporte sencillo y seguro de los barriles de 210lt; puede ser utilizado con grúas o montacargas para talleres mecánicos

- Para el levantamiento de barriles totalmente en acero de 210 litros;
- Funciona de manera sencilla con gruas o carretillas elevadoras;
- Mueve y gestiona barriles de acero abiertos o cerrados;
- Permite una carga rápida y precisa en sobreembalajes y mantiene el barril en posición vertical durante la elevación, reduciendo los derrames y la posibilidad de lesiones

Capacidad de carga: 350kgs  
Peso bruto/neto: 9,5/11,5kgs  
Dimensiones embalaje: 490x260x210mm



Cod. 05.084.05P

€ 242,00

**SOLLEVATORE IDRAULICO DA FOSSA  
CON COMANDO A PEDALE**

Fornito con supporto a croce a quattro braccia (A) e supporto inclinabile per allineamento cambi e differenziali (B)

**DOPPIA CULLA  
INTERCAMBIABILE  
(A+B)**

**INTERCHANGEABLE  
DOUBLE CRADLE  
(A + B)**

**CUNA DOBLE  
INTERCAMBIABILE  
(A + B)**

**HYDRAULIC TRANSMISSION JACK WITH FOOT CONTROL**

Supplied with a 4-arms crosswise support (A) and adjustable support for the alignment of gearboxes and differentials (B)

**GATO HIDRAULICO PARA TRANSMISIONES  
CON CONTROL DE PEDAL**

Se suministra con un soporte de 4 brazos en cruz (A) y soporte ajustable para la alineación de cajas de cambio y diferenciales (B)

**HOT!**



CARATTERISTICHE TECNICHE	TECHNICAL FEATURES	CARACTERISTICAS TECNICAS
-----------------------------	-----------------------	-----------------------------

Capacità: 500 Kg	Capacity: 500 Kg	Capacidad: 500kgs
Pompa a pedale	Foot pump	Bomba de pie
Valvola limitatrice di carico	Overload safety valve	Válvula de seguridad de sobrecarga
Ruote in nylon	Nylon wheels	Ruedas de nylon
Altezza max : 1990 mm	Max height: 1990mm	Altura máx.: 1990mm
Altezza min 1140	Min. height: 1140mm	Altura min.: 1140mm



**UNITÀ DI ASPIRAZIONE OLIO MOTORE**

pneumatica, carrellata, con sonde di aspirazione, connettore di raccolta sottoponte, completo di pre-camera

**MOTOR OIL SUCTION UNIT**

Pneumatic, on trolley, with suction probes, under bridge connector for collection, complete with pre-chamber

**UNIDAD DE ASPIRACIÓN DE ACEITE MOTOR**

Neumática, novil, con sondas de aspiración, conector bajo-puente para la recolección, con pre-cámara

Cod. 03.036.18NEW

€ 380,00

**DATI TECNICI:**

- Serbatoio: 90lt
- Pre-camera graduata: 8lt
- Dimensioni: 400x400x1300mm
- Peso: 35kg
- Pressione aria: 1 ÷ 2 bar

**TECHNICAL FEATURES:**

- Tank: 90lt
- Graduated pre-chamber: 8lt
- Dimensions: 400x400x1300mm
- Weight: 35kg
- Air pressure: 1 ÷ 2 bar

**DATOS TÉCNICOS:**

- Tanque: 90lt
- Precámara graduada: 8lt
- Dimensiones: 400x400x1300mm
- Peso: 35 kg
- Presión del aire: 1 ÷ 2 bar

NEW!  
2018

**SCARICATORE PER OLIO ESAUSTO**

WASTE OIL DRAINER

ESCURRIDOR DE ACEITE USADO



Cod. 03.036.26

€ 138,00

**DATI TECNICI:**

- Capacità serbatoio: 70 lt
- Capacità imbuto: 10 lt
- Altezza: 1,65 mt
- Alimentazione: aria compressa
- Pressione max per scarico olio: 1 bar
- Dimensioni imballo: 50 x 44 x 96 cm

**TECHNICAL FEATURES:**

- Tank capacity: 70 lt
- Funnel capacity: 10 lt
- Height: 1.65 mt
- Powered by compressed air
- Max. oil drain pressure: 1 bar
- Packaging dimensions: 50 x 44 x 96 cm

**DATOS TÉCNICOS:**

- Presión de entrada: 2,8 ÷ 5,6bar (40-80 PSI)
- Consumo de aire: 450 ÷ 550 lt /min
- Dimensiones de la cámara: 596x838x625mm
- Dimensiones del embalaje: 96x62x62,5cm
- Peso neto/bruto: 48/51kg

**SCARICATORE DIRETTO PER OLIO ESAUSTO**

DIRECT WASTE OIL DRAINER

ESCURRIDOR DE ACEITE USADO DIRECTO

Cod. 03.036.27

€ 107,00

NEW!  
2018

**DATI TECNICI:**

- Altezza dell'imbuto: min. 103cm / max. 170cm
- Peso: 18 kg
- Dimensioni imballo: 93 x 42,5 x 21,5 cm

**TECHNICAL FEATURES:**

- Height of the funnel: min. 103cm / max. 170cm
- Weight: 18 kg
- Packaging dimensions: 93 x 42.5 x 21.5 cm

**DATOS TÉCNICOS:**

- Altura del embudo: min. 103 cm / máx. 170cm
- Peso: 18 kg
- Dimensiones de embalaje: 93 x 42.5 x 21.5 cm







**Pistone mobile  
Dispositivo di ritorno del pistone**

**Mobile piston  
Piston return device**

**Pistón móvil  
Dispositivo de retorno del pistón**

**Nuova pompa con avanzamento rapido e lento  
New pump with fast and slow motion speed  
Nueva bomba con avance rapido y lento**

Cod. 03.031.32

€ 690,00

**PRESSA IDRAULICA DA 30 TON**  
PER OFFICINE MECCANICHE AUTO, MOTO, MACCHINE AGRICOLE,  
MANUTENZIONE INDUSTRIALE

**30 TONS HYDRAULIC PRESS**  
FOR MECHANICAL WORKSHOPS FOR AUTO, MOTO, AGRICULTURAL MACHINES,  
INDUSTRIAL MAINTENANCE

**PRENSA HIDRÁULICA DE 30 TONELADAS**  
PARA TALLERES MECANICOS PARA AUTO, MOTO,  
MÁQUINAS AGRÍCOLAS, MANTENIMIENTO INDUSTRIAL

Capacità: 30 tonnellate  
Corsa pistone: 160mm  
Min. distanza operativa: 240mm  
Max. distanza operativa: 940mm  
Pompa manuale a doppio effetto  
Pistone mobile  
Dimensioni imballo:  
1570x280x350mm (pressa smontata)  
Peso netto/lordo:  
130/141kg  
Dimensioni pressa montata:  
700x830x h 1770 mm

Capacity: 30 tons  
Piston stroke: 160mm  
Min. working distance: 240mm  
Max. working distance: 940mm  
Manual double-acting pump  
Moving piston  
Package dimensions:  
1570x280x350mm (dismantled press)  
Net/gross weight:  
130/141kg  
Dim. assembled press:  
700x830x h1770 mm

Capacidad: 30 toneladas  
Carrera del pistón: 160 mm  
Min. distancia de trabajo: 240 mm  
Max. distancia de trabajo: 940 mm  
Bomba manual de doble accion  
Pistón móvil  
Dimensiones embalaje:  
1570x280x350mm (pressa desmontada)  
Peso neto/bruto:  
130/141 kg  
Dimensiones pressa montada:  
700x830x h1770 mm

**CORREDO STANDARD  
STANDARD EQUIPMENT  
EQUIPAMIENTO ESTANDAR**

**COPPIA PIASTRE IN ACCIAIO CON INTAGLIO A "V"  
PAIR OF STEEL PLATES WITH V-CARVING  
PAR DE PLACAS DE ACERO CON TALLA EN V**

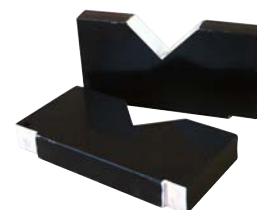

Cod. 03.031.33

€ 220,00

**CORREDO A RICHIESTA - EQUIPMENT UPON REQUEST - EQUIPAMIENTO BAJO PEDIDO**



**SERIE DI 6 PUNZONI IN ACCIAIO C40**  
per estrazione cuscinetti/boccole

**SET OF 6 PUNCHES IN C40 STEEL**  
for removing bearings/bushings

**JUEGO DE 6 PUNZONES EN ACERO C40**  
para sacar cojinetes/bushings

Ø 5-10-14-18-24-29 mm



**PIASTRONE PER SMONTAGGIO  
CUSCINETTI/BOCCOLE**

**LARGE PLATE FOR REMOVING  
BEARINGS/BUSHINGS**

**PLACA GRANDE PARA SACAR  
COJINETES/BUSHINGS**



**2 COPPIE FLANGE ESTRATTRICI**

**2 PAIRS OF EXTRACTING FLANGES**

**2 PARES DE PESTAÑAS DE EXTRACCIÓN**

Ø35-50mm - Ø50-75mm

Cod. 05.075.16

€ 1.642,00

CYCLONE  
420Lt  
INDUSTRIAL

SABBIATRICE INDUSTRIALE CON  
ASPIRATORE A CICLONE 420 LT  
CON APERTURA SUPERIORE

PNEUMATIC SANDBLASTER WITH  
420 LTS CYCLONE VACUUM, WITH  
TOP OPENING DOOR

ARENADORA INDUSTRIAL DE 420  
LT CON ASPIRADOR A CICLÓN CON  
APERTURA SUPERIORE



- Comando a pedali
- L'aspiratore a ciclone assicura una estrazione di polvere e sabbia in continuo
- L'illuminazione interna (alogeno)
- Apertura ampia per l'introduzione dei pezzi
- Regolatore di pressione

**DATI TECNICI:**

- Dimensioni esterne: 1210x610x1700 mm
- Dimensioni camera interna: 1200x600x370/600 mm
- Dimensioni porta accesso: 1000x570cm
- Dimetro ugello: 6,7 mm
- Consumo d'aria: 160-170 lt/min
- Pressione di lavoro: 3,5 ÷ 5,5 bar
- Max. pressione ammessa: 8 bar
- Alimentazione: 230 V 50H7

**ACCESSORI STANDARD:**

- 4 ugelli
- 1 pistola sabbiatrica (industriale)
- 2 lampade alogene
- 5 protezioni per luce interna
- 2 nastri a rullo
- 1 nastro a rullo teflon
- 1 contenitore a ciclone
- 1 comando a pedale
- 1 separatore acqua-aria

- Foot pedal operated
- The cyclonic vacuum assures the continuous extraction of the dust and the sand
- Inner lighting (halogen)
- Large opening for the insertion of the components
- Pressure regulator

**TECHNICAL FEATURES:**

- External dimensions: 1210x610x1700mm
- Blasting cabinet size: 1200x600x370/600mm
- Opening door size: 1000x570cm
- Nozzle size: 6,7 mm
- Air consumption: 160-170 lt/min
- Operating pressure: 3,5 ÷ 5,5 bar
- Max. pressure: 8 bar
- Voltage: 230 V 50H7

**STANDARD EQUIPMENT:**

- 4 ceramic nozzles
- 1 sand blasting gun (industrial)
- 2 halogen lamps for the inner lighting
- 5 safety films for the inner lighting
- 2 rolls of sealant tape
- 1 roll teflon sealant
- Cyclone tank
- Control pedal
- 1 water-separator

- Mandos de pedal
- El aspirador a ciclón garantiza una extracción de polvo y arena continuamente
- Iluminación interior (halógena)
- Amplia apertura para la introducción de los componentes
- Regulador de presión

**DATOS TÉCNICOS:**

- Dimensiones externas: 1210x610x1700 mm
- Dimensiones de la cámara interior: 1200x600x370/600 mm
- Dimensiones puerta de acceso: 1000x570mm
- Diámetro boquilla: 6,7 mm
- Consumo de aire: 160-170 lt/min
- Presión de trabajo: 3,5 ÷ 5,5 bar
- Max. presión admisible: 8 bar
- Alimentación: 230 V 50H7

**EQUIPAMIENTO STANDARD:**

- 4 boquillas
- 1 pistolar para arenadora
- 2 lamparas halógenas
- 5 protecciones interiores
- 2 rodillo de cinta
- 1 rodillo de cinta teflon
- 1 contenedor a ciclón
- 1 pedal
- 1 separador agua-aire

Cod. 05.075.10

€ 510,00



220Lt

**DATI TECNICI:**

- Pressione d'ingresso: 2,8 ÷ 5,6bar (40-80 PSI)
- Consumo d'aria: 450 ÷ 550 lt/min
- Dimensioni camera: 596x838x625mm
- Dimensioni imballo: 96x62x62,5cm
- Peso netto/lordo: 48/51kg
- Predisposizione per aspiratore (non fornito)

**ACCESSORI STANDARD:**

- Coppia guanti L=60cm
- Set ugelli pistola
- Pistola sabbiatrica

**DATI TECNICI:**

- Technical features:
- Inlet pressure: 2.8 ÷ 5,6bar (40-80 PSI)
- Air consumption: 450 ÷ 550 lt /min
- Chamber size: 596x838x625mm
- Package dimensions: 96x62x62,5cm
- Net/gross weight: 48/51kg
- Predisposition for aspirator (not supplied)

**STANDARD ACCESSORIES:**

- Pair of gloves L=60cm
- Set nozzles for gun
- Gun for sandblaster

**DATI TECNICI:**

- Presión de entrada: 2,8 ÷ 5,6bar (40-80 PSI)
- Consumo de aire: 450 ÷ 550 lt /min
- Dimensiones de la cámara: 596x838x625mm
- Dimensiones del embalaje: 96x62x62,5cm
- Peso neto/bruto: 48/51kg
- Predisposición para aspirador (no suministrado)
- **EQUIP. ESTANDAR:**  
Par de guantes L=60 cm
- Juego de boquillas para pistola
- Pistola para arenadora

SABBIATRICE PNEUMATICA  
PNEUMATIC SANDBLASTER  
ARENADORA NEUMATICA

Cod. 05.075.17

€ 702,00

SABBIATRICE CARRELLATA CON  
ASPIRATORE INCORPORATO DA 105 LT  
105 LTS SANDBLASTER WITH WHEELS  
WITH BUILT-IN VACUUM DEVIC

ARENADORA CON RUEDAS CON ASPIRADOR  
INCLUIDO, 105 LT

105Lt



- Aspiratore incorporato
- Consente l'uso continuo dell'apparecchio
- Recupera le parti di abrasivo separandole dalla polvere
- Può essere usato su pietra e superfici metalliche

- Built-in vacuum
- it allows continuous work
- recovers abrasive parts separating them from dust
- It can be used on stone or metallic surfaces

- Aspirador incorporado
- Permite el uso del dispositivo
- Recupera partes de abrasivo separandolas de polvo
- Puede ser utilizada sobre piedras y superficies metálicas

DATI TECNICI:

- Pressione aria compressa: 8 bar
- Consumo di aria: 170÷640 lt/min (a seconda dell'uso)
- A: Aspiratore da 1200W
- B: Spazzola
- Connessione aria: 1/2"
- Capacità serbatoio: 105lt, 1041x367(Ø)mm
- Peso netto/lordo: 36kg /40 kg

TECHNICAL FEATURES:

- Compressed air pressure: 8 bar
- Air consumption: 170÷640 lt/min (depending on use)
- A: 1200W Vacuum device
- B: Brush
- Air connection: 1/2"
- Tank size: 105lt 1041x367(Ø)mm
- Net/gross: 36kg /40 kg

DATOS TÉCNICOS:

- Max presión aire comprimido: 8 bar
- Consumo de aire: 170÷640 lt/min (depende del uso)
- A: Aspirador de: 1200W
- B: Cepillo
- Conexión de aire: 1/2"
- Capacidad de el tanque: 105lt 1041x367(Ø)mm
- Peso neto/bruto: 36kg /40 kg



Cod. 05.075.18

€ 307,00

SABBIATRICE CARRELLATA DA ESTERNO 75 LT  
PORTABLE SANDBLASTER 75L, FOR EXTERNAL USE  
ARENADORA CON RUEDAS PARA USO EXTERNO 75LT

75Lt



- L'aria e l'abrasivo sono miscelati nel serbatoio
- La miscela aria+abrasivo viene accelerata dall'ugello conico amplificando l'effetto sabbiante

- The air and the sand are mixed in the tank with compressed air
- The mixture speeds up at the cone shaped nozzle in the hose, amplifying the effectivity of the blasting process

- Aire y abrasivo son mezclados en el tanque
- La mezcla aire+abrasivo es acelerada por las boquillas cónicas ampliando el efecto de arena

DATI TECNICI:

- Capacità serbatoio: 75 lt
- Consumo d'aria: 170-710 lt/min
- Pressione di lavoro: 6 ÷ 10 bar
- Dimensioni esterne: 920x780x380mm
- Dimensioni imballo: 880x460x420mm

TECHNICAL FEATURES:

- Tank capacity: 75lt
- Air consumption: 170-710 lt/min
- Operating pressure: 6 ÷ 10 bar
- Total size: 920x780x380mm
- Packaging size: 880x460x420mm

DATOS TÉCNICOS:

- Capacidad de el tanque: 75 lt
- Consumo de aire: 170-710 lt/min
- Presión de trabajo: 6 ÷ 10 bar
- Dimensiones exteriores: 920x780x380mm
- Dimensiones del embalaje: 880x460x420mm

RICAMBI SABBIATRICI / SANDBLASTERS SPARE PARTS / RECAMBIOS ARENADORAS

Ricambi sabbiatrici Sandblasters spare parts Recambios arenadoras	 Cod. 05.075.16	 Cod. 05.075.10	 Cod. 05.075.17	 Cod. 05.075.18
Set ugelli Set of nozzles Juego de boquillas para pistola	 Cod. 05.075.22 € 12,80	 Cod. 05.075.11 € 5,00	 Cod. 05.075.26 € 5,50	 Cod. 05.075.24 € 5,50
Pistola sabbiatrice Blasting gun Pistola para arenadora	 Cod. 05.075.23 € 41,50	 Cod. 05.075.13 € 22,00	 Cod. 05.075.28 € 12,00	Cod. 05.075.25 € 20,00 Tubo 2,5 mt per sabbiatrice cod. 05.075.18 2,5mt hose for sandblaster cod. 05.075.18 Tubo 2,5mt para arenadora cod. 05.075.18
Coppia guanti Pair of gloves Par de guantes	 Cod. 05.075.21 € 22,90	 Cod. 05.075.12 € 16,80		

MATERIALE DI CONSUMO  
CONSUMABLES

Cod. 05.075.14 € 72,00

Corindone 80 gr per sabbiatrice  
Sacco da 25kg  
Corundum 80gr. for the sandblaster,  
25kg bag  
Corindón 80 gr para arenadora  
Saco 25 kg

Cod. 05.075.15 € 72,00

Corindone 60 gr per sabbiatrice  
Sacco da 25kg  
Corundum 60gr. for the sandblaster,  
25kg bag  
Corindón 60 gr para arenadora  
Saco 25 kg

Cod. 05.075.27 € 80,00

Microsfere, grana 40/70 micron,  
sacco da 25kg  
Micro glass beads, grain size 40/70  
micron, 25kg bag  
Microesferas, grano 40/70 micras,  
saco 25 kg



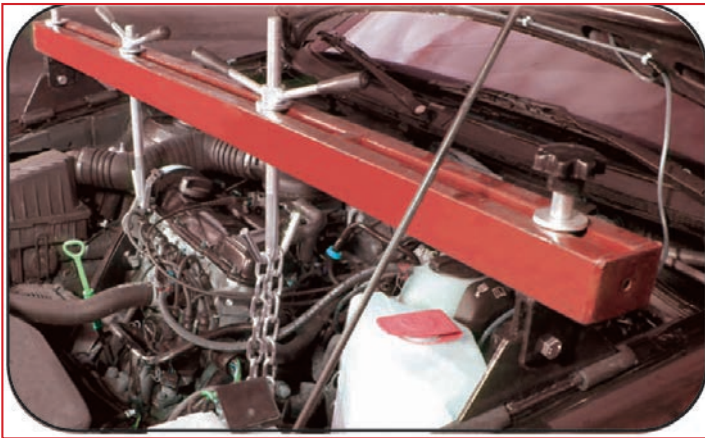

Cod. 05.084.04

€118,00

**ENGINE LIFTING CRANE  
SOPORTE DE ELEVACIÓN DEL MOTOR  
CAPRETTA SOLLEVAMENTO MOTORI**



Capacity: 500kgs  
Supports adjustment:  
1100 ÷ 1600mm  
Weight: 22kgs

Capacidad: 500kgs  
Ajuste apoyos:  
1100 ÷ 1600mm  
Peso: 22kgs

Portata: 500kgs  
Agganci regolabili:  
1100 ÷ 1600mm  
Peso: 22kgs



Cod. 05.085.08

€310,00

**GRU SMONTABILE DA OFFICINA  
DISMOUNTABLE CRANE FOR MECHANIC WORKSHOPS  
GRUA DESMONTABLE PARA TALLER MECANICO**

**TECHNICAL FEATURES / CARACTERISTICAS TECNICAS  
CARATTERISTICHE TECNICHE**

Special feature: Particularidad: Particolarità:	double effect piston pistón a doble efecto pistone a doppio effetto
Capacity: Capacidad: Capacità:	1 ton
Measures: Medidas: Misure:	1620mmx930x1600hmm
Weight: Peso: Peso:	76kgs
Dimensions (packed): Dimensiones embalaje: Dimensioni imballo:	800x860x1600hmm



**Moltiplicatore di coppia  
per smontaggio bulloni di camion e furgoni**

**Multiplier-couple for  
the disassembly of the truck and van bolts**

**Multiplicador de par para desmontaje bulones  
de camiones y furgonetas**

- Coppia massima: 3800 Nm
- Rapporto riduzione: 1:56

- Maximum torque 3200 Nm
- Gear ratio: 1:56

- Par máximo: 3200 Nm
- Relación de transmisión: 1:56

Cod. 05.090.10

€114,00

- Include 7 bussole chrome vanadium da 24 a 38 mm
- Including 7 sockets chrome vandadium from 24 to 38 mm
- 7 casquillos chrome vanadium desde 24 hasta 38 mm



Cod. 05.090.13

€70,00

**HOT!**

- Include 2 bussole da 32 a 33 mm
- Including 2 sockets from 32 a 33 mm
- 2 casquillos desde 32 hasta 33 mm



**Booster Line**

**Batterie AGM - AGM Batteries - Baterias AGM**

**BOCIA EVO 12/24V**

**Cod. 03.015.04**

**€ 480,00**

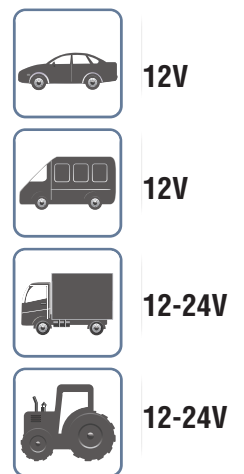

- 1) Nuova impugnatura ergonomica in gomma
- 2) Voltmetro
- 3) Stacca batteria
- 4) Presa 12 V
- 5) Luce a led di emergenza
- 6) Pinze con contatto in bronzo con treccia interna
- 7) Caricabatteria 4 Amp 100/240V
- 8) Commutatore 12V-0-24V
- 9) Adattatore USB
- 10) Cavo doppio accendisigari

- 1) New ergonomic rubber handle
- 2) Voltmeter
- 3) Battery switch
- 4) 12 V socket
- 5) Emergency led light
- 6) Pliers with bronze contact and internal braid
- 7) Battery charger 4 Amp 100/240V
- 8) Switch 12V-0-24
- 9) USB adapter
- 10) Double cigarette lighter cable

- 1) Nuevo mango ergonómico de goma
- 2) Voltímetro
- 3) Desconector de batería
- 4) Enchufe de 12 V
- 5) Luz LED de emergencia
- 6) Pinzas con contactos de bronce y cables trenzados
- 7) Cargador de baterías 4 Amp 100/240V
- 8) Conmutador 12V-0-24V
- 9) Adaptador USB
- 10) Cable doble encendedor de cigarrillos

**Nuove batterie**  
**2pz x 12 V 22Ah**  
**(4000A Picco - 12V)**  
**(2000A Picco - 24V)**

Garanzia 12 mesi

**New batteries**  
**2pcs x 12V22Ah**  
**4000A Peak - 12V**  
**2000A Peak - 24V**

12 months warranty

**Nueva batería 12 V 22Ah**  
**(4000A pico - 12V)**  
**(4000A pico - 12V)**

Garantía 12 meses





HAPPY VAN EVO 12V

Cod. 03.016.01

€ 460,00

CARATTERISTICHE TECNICHE:

- Nuova impugnatura ergonomica in gomma
- Voltmetro
- Stacca batteria
- Presa 12 V
- Luce a led di emergenza
- Pinze con contatto in bronzo con treccia interna
- Caricabatteria 4 Amp 100/240V
- Adattatore USB
- Cavo doppio accendisigari
- Nuove batterie  
**2pz x 12 V 22Ah (4000A Picco - 12V)**
- Garanzia 12 mesi

TECHNICAL FEATURES:

- New ergonomic rubber handle
- Voltmeter
- Battery switch
- 12 V socket
- Emergency led light
- Pliers with bronze contact and internal braid
- Battery charger  
4 Amp 100/240V
- USB adapter
- Double cigarette lighter cable
- New batteries  
**2pcs x 12 V 22Ah (4000A Peak - 12V)**
- 12 months warranty

CARACTERISTICAS TECNICAS:

- Nuevo mango ergonómico de goma
- Voltímetro
- Desconectador de batería
- Enchufe de 12 V
- Luz LED de emergencia
- Pinzas con contactos de bronce y cables trenzados
- Cargador de baterías 4 Amp 100/240V
- Adaptador USB
- Cable doble encendedor de cigarrillos
- Nueva batería **12 V 22Ah (4000A pico - 12V)**
- Garantía 12 meses



CORREDO STANDARD  
STANDARD ACCESSORIES  
ACCESORIOS ESTÁNDAR



PINZE PROFESSIONALI 1000A isolate per batterie auto/camion  
PROFESSIONAL PLIERS 1000A insulated for batteries of cars and trucks  
PINZAS PROFESIONALES 1000A aisladas para baterías de automóviles y camiones

Cod. 05.100.00 € 12,80

PINZA ROSSA / RED PLIERS /  
PINZAS ROJAS

Cod. 05.100.01 € 12,80

PINZA NERA / BLACK PLIERS /  
PINZAS NEGRAS

- Completamente isolata
- Terminali in bronzo (maggiore superficie di contatto sul polo batteria)
- Ampia apertura: max. 35mm
- Treccia in rame
- Minimo ingombro
- Fully insulated
- Terminals of bronze (bigger contact surface on the battery pole)
- Great opening: max. 35mm
- Copper braid
- Space-saving
- Totalmente aislado
- Terminales de bronce (superficie de contacto más grande en el polo de la batería)
- Gran apertura: max. 35mm
- Trenza de cobre
- Ahorro de espacio



BOCIA EVO 12V

Cod. 03.015.03

€ 240,00

CARATTERISTICHE TECNICHE:

- Nuova impugnatura ergonomica
- Pinze con contatto in bronzo con treccia interna
- Presa 12 V
- Controllo stato di carica (sotto carica)
- Controllo stato di carica (a riposo)
- Stacca batteria con allarme polarità invertita
- Carica batterie:  
1 Amp 100/240V
- Adattatore USB
- Cavo doppio accendisigari
- Nuova batteria  
**12 V 22Ah (2000A peak)**
- Garanzia 12 mesi

TECHNICAL FEATURES:

- New ergonomic handle
- Pliers with bronze contact and internal braid
- 12 V socket
- Charge indicator (under charge)
- Charge indicator (not under charge)
- Battery switch with reverse polarity alarm
- Battery charger:  
1 Amp 100/240V
- USB adapter
- Double cigarette lighter cable
- New battery  
**12V22Ah/2000A Peak**
- 12 months warranty

CARACTERISTICAS TECNICAS:

- Nuevo mango ergonómico
- Pinzas con contactos de bronce y cables trenzados
- Enchufe de 12 V
- Control del estado de carga (en carga)
- Control del estado de carga (sin cargar)
- Desconectador de batería con alarma de inversión polaridad
- Cargador de baterías:  
1 Amp 100/240V
- Adaptador USB
- Cable doble encendedor de cigarrillos
- Nueva batería  
**12 V 22Ah (2000A pico)**
- Garantía 12 meses





BT 777

Cod. 04.003.11

€ 440,00



**TESTER BATTERIE/ALTERNATORI con Stampante e Codici a Barre**  
**DIGITAL BATTERY/CHARGING STARTING SYSTEM ANALYSER with printer and barcode**  
**NEUVO PROBADOR DE BATERIAS con impresora y codigo de barras**

- 8 lingue:
- Contatore numero di test (Test counter) per garanzie e controllo qualità
- Codice a barre per rintracciabilità batterie (code 39) indispensabile per gestione garanzie
- Cavi di test sostituibili in caso di danneggiamento
- Dimensioni: 251x130x64
- Accessori: guscio antiurto, rotolo carta, 6 batterie 1.5
- 8 languages
- Test counter for warranty or quality control
- Bar code for the battery traceability (code 39) indispensable for warranty management
- Replaceable test cables in case of damage
- Dimensions: 251x130x64
- Accessories: shock-proof case, paper roll, 6 batteries 1.5
- 8 idiomas
- Contador número de pruebas (test counter) para garantías o controles de calidad
- Código de barras para trazabilidad baterías (code 39) imprescindible para gestión garantías
- Cables de prueba reemplazables en caso de danos
- Dimensiones : 251x130x64
- Accesorios : protección anticaida, rollo de papel, 6 baterías 1.5

ANCHE PER BATTERIE «START-STOP»  
 ALSO FOR «START-STOP» BATTERIES  
 TAMBIÉN PARA BATERIAS «START-STOP»

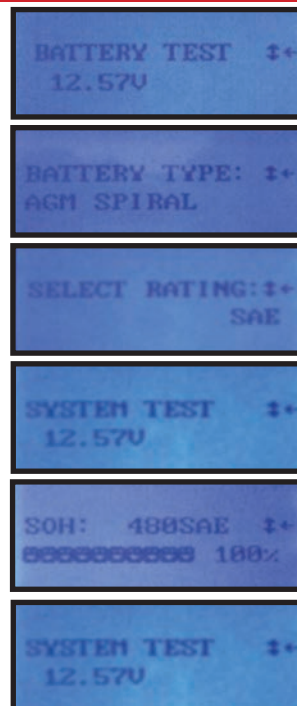

Application:  
 6V & 12V  
 Automotive Batteries

Battery Type:  
 a. Regular Liquid  
 b. AGM Flat Plate  
 c. AGM Spiral  
 d. VRLA/GEL

Norme / Global Battery Rating:  
 SAE(CCA), EN, IEC, DIN, JIS (Battery No.)

5 Test Results:  
 a. Good & Pass  
 b. Good & Recharge  
 c. Recharge & Retest  
 d. Bad & Replace  
 e. Bad Cell & Replace

SOH (State of Health)  
 SOC (State of Charge)

System Test:  
 12V & 24V  
 a. Starter Test  
 b. Charging Test

BT 002

Cod. 04.003.08

€ 168,00



**TESTER BATTERIE 6-12V test impianto di ricarica e avviamento 12-24v**

**BATTERY TESTER 6-12V charging and starting system 12-24v test**

**PRUEBA BATERÍAS 6-12V prueba instalación de recarga y arranque 12-24v**

BT 501

Cod. 04.003.04

€ 320,00



**TESTER BATTERIE DIGITALE analizzatore sistema di carica e avviamento con stampante**

**DIGITAL BATTERY TESTER charging and starting system analyser with printer**

**TESTER BATERÍAS DIGITAL analizador instalación de recarga y arranque con impresora**

BT 222

Cod. 04.003.09

€ 62,00



**TESTER BATTERIE/ IMPIANTO DI CARICA 12V**

**BATTERY TESTER/ CHARGING SYSTEM 12V**

**TESTER BATERÍAS/ INSTALACIÓN DE RECARGA 12V**

Cod. 05.081.04

€ 17,00

**CAVO OBD II**

**Presse accendisigari per booster (solo 12V)**

**OBD II CABLE**

**cigarette lighter socket for booster (only 12V)**

**CABLE OBD II**

**toma encendedor de cigarillos para arrancador (sólo 12V)**



BOOSTER PORTATILI  
LINEA CLASSIC  
CON BATTERIE AGM

PORTABLE BOOSTERS  
"CLASSIC" SERIES  
WITH AGM BATTERIES

LINEA DE ARRANCADORES  
PORTATILES "CLASSIC"  
CON BATERIAS AGM

Cod. 03.015.00

€ 380,00

F3000

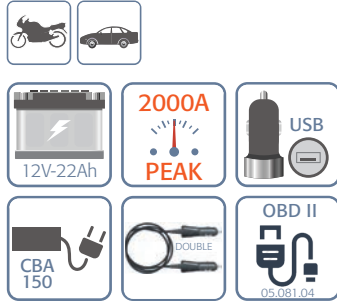

Cod. 03.016.00

€ 550,00

HAPPY VAN 12V



Cod. 03.015.01

€ 780,00

F4000

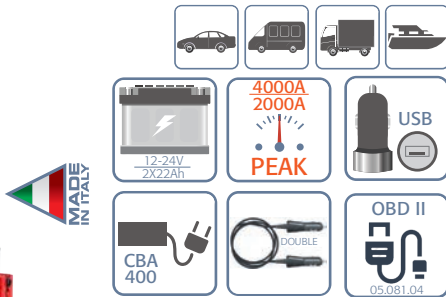

Cod. 03.018.01

€ 1.142,00

HAPPY TIR NEW 12-24V

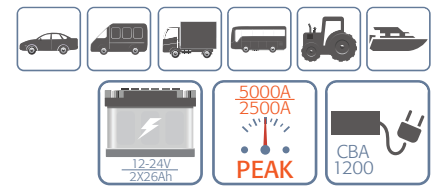

Cod. 03.018.04

€ 25,00

> Carrello in alluminio leggero per F4000  
> Lightweight aluminium trolley for F4000

Cod. 05.088.03

€ 39,90

> Carrello per New Happy Tir  
> Trolley for New Happy Tir

Cod. 03.019.01





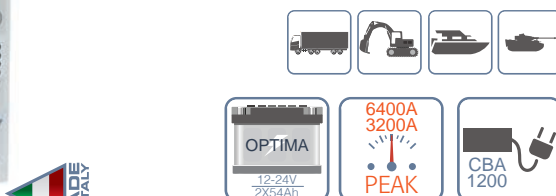

€ 1.590,00

HAPPY TANK PLUS 12-24V



Dotazione standard	Standard equipment	Equipamiento estandar	F3000 12V	F4000 12-24V	Happy Van 12V	New Happy Tir 12-24V	Happy Tank 12-24V
CARICA BATTERIE AUTOMATICO AUTOMATIC BATTERY CHARGER CARGADOR DE BATERIA AUTOMATICO 12V - 1,5A CBA 150N COD. 03.024.01			√	-	-	-	-
CARICA BATTERIE AUTOMATICO AUTOMATIC BATTERY CHARGER CARGADOR DE BATERIA AUTOMATICO 12V - 4A CBA 400 COD. 03.024.09			-	√	√	-	-
> CARICA BATTERIE AUTOMATICO. 12A 14V (PER NEW HAPPY TIR, HAPPY TANK PLUS) > AUTOMATIC BATTERY CHARGER. 12A 14V (PER NEW HAPPY TIR, HAPPY TANK PLUS) CBA 1200B COD. 03.024.06			-	-	-	√	√
CAVO DOPPIO ACCENDISIGARI DOUBLE CABLE FOR CIGARETTE LIGHTER SOCKET CABLE DOBLE PARA TOMA DE ENCENDEDOR DE CIGARILLOS			√	√	√	-	-
CAPACITÀ BATTERIE (AMPERE - PICCO) BATTERIES' CAPACITY (AMPERE PEAK) CAPACIDAD BATERIAS (PICO DE AMPERIOS)			22AH 2000A	2X22AH 4000/2000A	26AH 2500A	2X26AH 5000/2500A	2X54AH 6400/3200A
ADATTATORE USB USB ADAPTER ADAPTADOR USB COD. 05.096.04			√	√	√	-	-
CAVO OBD II PRESA ACCENDISIGARI OBD II CABLE FOR CIGARETTE LIGHTER SOCKET CABLE OBD II PARA TOMA DE ENCENDEDOR DE CIGARILLOS COD. 05.081.04			√	√	√	-	-

Garanzia 12 mesi - Garanzia 12 mesi - Garantía 12 meses

APPLICAZIONI CONSIGLIATE SUGGESTED USES USOS SUGERIDOS							
F3000 12V	•	•	-	-	-	-	-
F4000 12-24V	•	•	•	•	< 7 TON	•	•
HAPPY VAN 12V	•	•	•	-	-	-	-
NEW HAPPY TIR 12-24V	•	•	•	•	•	•	•
HAPPY TANK PLUS 12-24V	•	•	•	•	•	•	•



Cod. 03.020.07

€ 236,<sup>00</sup>

**BOOSTER 12V A SCARICA CAPACITATIVA**  
**12V BOOSTER WITH CAPACITIVE DISCHARGE**  
**BOOSTER 12V CON DESCARGA CAPACITIVA**



**Caratteristiche tecniche - Technical features - Características técnicas**

Ingresso - Inlet - Entrada	12V10A 5V2A	Da cavo di avviamento veloce dalla batteria veicolo Via jumper cable from car battery Con el cable de arrancamiento desde la batería del vehículo	
Uscite - Ouput - Salida	12V awiamento veloce Luce LED	12V jump start LED Light	12V para arrancamiento Luz LED
Corrente di picco - Peak current - Corriente de pico	700A (350A CCA)		
Dimensioni - Dimensions - Dimensiones	250*120*50mm		
Peso - Weight - Peso	1300gr.		
Temperatura operativa Operating temperature Temperatura de funcionamiento	-20°C / +60°C		
Durata - Operating life - Vida útil	>100.000 cicli	>100.000 cicli	>100.000 ciclos
Capacità/tempo di ricarica batteria tampone Buffer battery capacity/charging time Capacidad de la batería tampón/tiempo de carga	6000mAh	(carica completa 4,5h da 5V2A, batterie tampone 50min. da 12V10A) (complete charge 4,5h from 5V2A, buffer batteries 50min. from 12V10A) (carga completa 4,5h desde 5V2A, baterías tampón 50min. desde 12V10A)	

**Dotazione standard**

**Standard equipment**

**Equipamiento estandar**



- Carica batterie accendisigari
- Cigarette lighter charger
- Cargador para encendedor de sigarillos



- Cavo USB
- USB cable
- Cable USB



- Confezione
- Packaging
- Embalaje

AVVIATORE 12/24V CON BATTERIE LiFePo4  
 12/24V BOOSTER WITH LiFePo4 BATTERY  
 ARRANCADOR 12 / 24V CON BATERÍAS LiFePo4

Cod. 03.020.08

€ 396,00

**POWER PACK TRUCK**  
**35000 mAh**

**NEW!**  
**2018**

RICONOSCIMENTO AUTOMATICO TIPO DI IMPIANTO  
 RECONOCIMIENTO AUTOMÁTICO DEL TIPO DE SISTEMA  
 AUTOMATIC RECOGNITION OF THE SYSTEM TYPE



**Contiene batterie LiFePO<sub>4</sub>**  
 LiFePO<sub>4</sub> battery inside  
 Contiene baterías LiFePO<sub>4</sub>



**DATI TECNICI:**

- Capacità batterie: 3.2V 35000mAh
- Caricabatterie: 15V 2A
- Uscite:
  - USB 5V/2A (tablet e dispositivi elettronici)
  - USB 5V/1A (cellulari)
  - 12V/10A (da accendisigari)
  - 12V/avviamento
  - 24V/avviamento
  - lampada 3W, 250 lumen
- Corrente di avviamento: 600A/12V – 300A(24V)
- Corrente di picco 1200A/12V-600A(24V)
- Dimensioni: 292x233x79 mm
- Peso: 2680 gr
- Cicli di ricarica: >2000

**CORREDO STANDARD:**

- A: Caricabatterie accendisigari, 12V 10A
- B: Cavo USB, 5V 2A
- C: Confezione
- D: Caricabatterie 12/24V da presa accendisigari

**TECHNICAL FEATURES:**

- Batteries capacity: 3.2V 35000mAh
- Batteries charger: 15V2A
- Outputs:
  - USB 5V/2A (tablets and electronical devices)
  - USB 5V/1A (mobile phones)
  - 12V/10A (cigar port)
  - 12V/jump start
  - 24V/jump start
  - lamp 3W, 250 lumen
- Jump start power: 600A/12V – 300A(24V)
- Peak current 1200A/12V-600A(24V)
- Dimensions: 292x233x79 mm
- Weight: 2680 gr
- Charging cycles: >2000

**STANDARD EQUIPMENT:**

- A: Cigarette lighter charger, 12V 10A
- B: USB cable, 5V 2A
- C: Packaging
- D: 12/24V cigarette lighter battery charger

**DATOS TÉCNICO:**

- Capacidad baterías: 3.2V 35000mAh
- Cargador: 15V2A
- Salidas:
  - USB 5V/2A (tablets y dispositivos electrónicos)
  - USB 5V/1A (mòbiles)
  - 12V/10A (ecendedor)
  - 12V/arranque
  - 24V/arranque
  - lámpara 3W, 250 lumen
- Corriente de arranque: 600A/12V – 300A(24V)
- Pico de corriente 1200A/12V-600A(24V)
- Dimensiones: 292x233x79 mm
- Peso: 2680 gr
- Ciclos de carga: >2000

**EQUIPAMIENTO ESTANDAR:**

- A: Cargador para encendedor de cigarillos, 12V 10A
- B: Cable USB, 5V 2A
- C: Embalaje
- D: Cargador de batería 12/24V para encendedor de cigarillos

AVIATORI CON BATTERIA LITIO/BOOSTERS WITH LITHIUM BATTERIES/ARRANCADORES CON BATERÍAS DE LITIO

La nuova tecnologia delle batterie al litio per l'avviamento di vetture benzina e diesel e l'alimentazione di tutti i tipi di utenze elettroniche (cellulari, tablet, computer, fotocamere).

The new technology of lithium batteries for the starting of diesel/petrol engine cars and charging of all kinds of electronic devices (mobile phones, tablets, computer, cameras).

La nueva tecnología de baterías de litio para el arranque de los automóviles con motor diesel/gasolina y carga de todo tipo de dispositivos electrónicos (teléfonos móviles, tabletas, ordenadores, cámaras).

Cod. 03.020.01

€ 146,00

POWER PACK 16 000 mAh



**16000mAh**  
(12V 400A picco/peak/pico)

- Adattatori per laptop/Laptop adapters/Adaptadores para ordenador
- (uscite/ports/puertos 1 USB 5V/1A - 12V - 16V - 19V)
- Cavo avviamento tipo "smart"/Starting cable "smart" type  
Cable de démarrage de type "smart"/Cable de arranque tipo "smart"
- Cavo multipolare/Multipolar cable/Cable multipolar
- Dimensioni/dimensions/dimensiones: 165x79x40mm
- Peso/Weight: 456gr

Cod. 03.020.06

€ 196,00

POWER PACK 20 000 mAh



**20.000mAh**  
(12V 900A picco/peak/pico)

- Adattatori per laptop/Laptop adapters/Adaptadores para ordenador
- (uscite/ports/puertos 1 USB 5V/1A - 12V - 16V - 19V)
- Cavo avviamento tipo "smart"/Starting cable "smart" type  
Cable de démarrage de type "smart"/Cable de arranque tipo "smart"
- Cavo multipolare/Multipolar cable/Cable multipolar
- Dimensioni/dimensions/dimensiones: 225x90x30mm
- Peso/Weight: 680gr

Cod. 03.020.02

€ 330,00

POWER PACK 30 000 mAh



**30.000mAh**  
(12V 400A, 800A picco/peak/pico)  
(24V 300A 600A picco/peak/pico)

- Adattatori per laptop/Laptop adapters/Adaptadores para ordenador
- (uscite/ports/puertos 2 USB 5V/2,1A - 12V - 16V - 19V)
- Cavo multipolare/Multipolar cable/Cable multipolar
- Dimensioni/dimensions/dimensiones: 200x164x90mm
- Peso/Weight: 1500gr

Disponibilità ricambi (cavi, caricabatterie) per tutti i modelli attuali e passati.

Spare parts available (cables, battery chargers) for any current or past model.

Repuestos disponibles (cables, cargadores de batería) para cualquier model presente o pasado.

Prezzi a richiesta

Prices upon request

Precios bajo solicitud



DOTAZIONE STANDARD/STANDARD EQUIPMENT  
EQUIPAMIENTO ESTANDAR











Cod. 03.020.01  
Power Pack  
16 000 mAh

Cod. 03.020.06  
Power Pack  
20 000 mAh

Cod. 03.020.02  
Power Pack Truck  
30 000 mAh

Cod. 03.020.08  
Power Pack Truck  
35 000 mAh

Caricabatterie 100÷240V Battery charger 100÷240V Cargador de batería		•	•	•	•
Caricabatterie da presa accendisigari Cigarette lighter battery charger Cargador de batería encendedor de cigarrillos		•	•	• <b>12/24 v</b>	• <b>12/24V</b>
Cavo multipolare (USB, cellulari, Iphone, Ipad) Multipolar cable (USB, mobile phones, Iphone, Ipad) Cable multipolar (USB, teléfonos móviles, Iphone, Ipad)		•	•	•	•
Adattatori per computer portatili Adapters for notebooks Adaptadores para portátiles		•	•	—	—
Cavo avviamento impianti 12V con protezione contro inversione e sotto-scarico 12V starting cable with protection against inversion and low charge Cable de arranque 12V con protección contra la inversión y la baja carga	<b>TIPO/TYPE "SMART"</b> 	•	•	•	<b>Automatic switch 12/24V</b>
Cavo avviamento impianti 24V con protezione contro inversione e sotto-scarico 24V starting cable with protection against inversion and low charge Cable de arranque 24V con protección contra la inversión y la baja carga		—	—	•	<b>Automatic switch 12/24V</b>
Luce a LED fissa/lampeggiante Steady/blinking LED light Luz LED fija/intermitente		•	•	•	•
Uscite USB/USB ports/Puertos USB		1USB 1.0A	1USB 1.0A 1USB 2.1A	1USB 1.0A 1USB 2.1A	1USB 1.0A 1USB 2.1A
Valigetta di trasporto Transport case Maletín de transporte					

APPLICAZIONI SUITABLE FOR							
03.020.01 	•	•	—	—	—	—	—
03.020.06 	•	•	•	• 12v	—	• 12v	• 12v
03.020.02 	•	•	•	• 12v-24v	• <7ton 24v	• 12v-24v	• 12v-24v
03.020.08 	•	•	•	•	•	•	•

# CHARGEMATE 12V 70A

Cod. 03.024.20

€ 630,<sup>00</sup>



## CARATTERISTICHE TECNICHE

- Caricabatterie automatico per batterie 12V ad acido, gel, AGM, LFP
- Selezione della carica da 3 a 70A
- Funzione **ALIMENTATORE A TAMPONE** (fino a 70A) con selezione della tensione alla batterie da 12.0 a 15.0V (step 0.1 volt) per riprogrammazione di centraline elettroniche
- Capacità di ricarica batterie: da 30 a 1800Ah
- Protezione contro sovraccarichi
- Protezione contro inversioni di polarità
- Tensione di alimentazione 220/240V 50/60Hz
- Dimensioni: 37x18x13,5cm
- Peso: 8,7kgs (con cavi)

## CORREDO BASE:

Coppia cavi ad occhiello 2,5mt (funzione show room)  
Cavi batteria staccabili sezione 16mm 2 x 2,5 mt

## TECHNICAL FEATURES

- Automatic battery charger for 12V acid, gel, AGM, LFP batteries
- Charge selection from 3 to 70A
- **BUFFER POWER SUPPLY** function (up to 70A) with selection of the tension supplied to the battery from 12.0 to 15.0V (0.1V step), used to reprogram control units
- Battery charge capacity: from 30 to 1800Ah
- Protection against overcharges
- Protection against polarity inversion
- Supplied tension 220/240V 50/60Hz
- Dimensions: 37x18x13,5cm
- Weight: 8,7kgs (with cables)

## STANDARD OUTFITS:

Pair of 2,5mt cables with eyelet (for showrooms)  
Detachable battery cables diam. 16mm 2 x 2,5mt

## CARACTERÍSTICAS TÉCNICAS:

- Cargador de baterías automático para baterías de ácido, gel, AGM, LFP de 12V
- Selección de carga de 3 a 70A
- Función de fuente de **ALIMENTACIÓN DE BÚFER** (hasta 70A) con selección de la tensión suministrada a la batería de 12.0 a 15.0V (paso de 0.1V), utilizada para reprogramar unidades de control
- Capacidad de carga de la batería: de 30 a 1800Ah
- Protección contra sobrecargas
- Protección contra inversión de polaridad
- Tensión suministrada 220 / 240V 50 / 60Hz
- Dimensiones: 37x18x13,5cm
- Peso: 8,7kgs (con los cables)

## EQUIPAMIENTO ESTANDAR:

Par de cables de 2,5mt con ojal (para showrooms)  
Cables de batería desmontables diam. 16mm 2x2.5mt



## Corredo standard / Standard equipment / Equipamiento estandar

A



B



MODELLI PER SPECIALISTI DIAGNOSI AUTO/CAMION  
CARICABATTERIE - ALIMENTATORI A TAMPONE

MODELS FOR SPECIALISTS ON CAR/TRUCK DIAGNOSIS  
BUFFER BATTERY CHARGERS - POWER SUPPLIERS

MODELOS PARA ESPECIALISTAS EN DIAGNÓSTICO DE COCHES/CAMIONES  
CARGADOR DE BATERÍA DE RESPALDO - ALIMENTADOR

# CHARGEMATE

## 12-24V / 100A

Cod. 03.024.17

€ 1.280,<sup>00</sup>



**DATI TECNICI:**

- Idoneo per uso automotive e industriale, CHARGEMATE ha funzione di caricabatteria a tecnologia Inverter con funzione di alimentatore a tampone nella fase di riprogrammazione di centraline elettroniche
- È dotato di display LCD con visualizzazione di tensione, corrente, Ah caricati, stato di carica della batteria
- Tipologia di batterie: piombo gel, AGM gel, LFP
- Corrente di carica: 3 ÷ 100A DC
- Tensione di carica: 12/24V
- Capacità batterie: 30/1200 Ah
- Modalità di impiego: caricabatterie - alimentatore
- Tensione di alimentazione: 220-240V
- Dimensioni: 29x34x13 (100A)
- Peso: 5kgs

**TECHNICAL FEATURES:**

- Ideal for use in the automotive and industrial field, CHARGEMATE is a battery charger with inverter technology that works as a buffer power supplier during the reprogramming of the electronic control unit
- It has a LCD screen which can display tension, current, charged Ah, charge status of the battery
- Type of batteries: gel-cell, AGM gel, LFP
- Charge current: 3 ÷ 100A DC
- Charge tension: 12/24V
- Batteries' capacity: 30/1200Ah
- Intended use: battery charger - power supplier
- Supply tension: 220-240V
- Dimensions: 29x34x13 (100A)
- Weight: 5kgs

**CARACTERÍSTICAS TÉCNICAS:**

- Ideal para el uso en el campo de la automoción e industrial, CHARGEMATE es un cargador de batería con tecnología inverter que funciona como proveedor de energía de respaldo de la unidad de control electrónico.
- Tiene una pantalla LCD que puede mostrar tensión, corriente, Ah cargados, estado de carga de la batería
- Tipo de baterías: plomo-gel, AGM gel, LFP
- Corriente de carga: 3 ÷ 100A DC
- Tensión de carga: 12/24V
- Capacidad de las baterías: 30/1200Ah
- Uso previsto: cargador de batería - proveedor de energía
- Tensión de alimentación: 220-240V
- Dimensiones: 29x34x13 (100A)
- Peso: 5 kgs

NEW!  
2018

# CHARGEMATE

## 12V / 140A

Cod. 03.024.21

Prezzo a richiesta  
Price on request  
Precio bajo pedido



**DATI TECNICI:**

- Idoneo per uso automotive e industriale, CHARGEMATE ha funzione di caricabatteria a tecnologia Inverter con funzione di alimentatore a tampone nella fase di riprogrammazione di centraline elettroniche
- È dotato di display LCD con visualizzazione di tensione, corrente, Ah caricati, stato di carica della batteria
- Il più potente sul mercato 12V/140A (idoneo per vetture BMW, Land Rover ecc.)
- Corrente di carica: 3 ÷ 140A DC
- Tensione di carica: 12V
- Settaggio della tensione di mantenimento 12.0 ± 15.0 con step di 0,1 volt
- Modalità di impiego: caricabatterie - alimentatore
- Cavo bipolare da 16mm<sup>2</sup> con connettori Anderson di sicurezza e pinze (A)
- Cavi Chargemate con terminale tipo Anderson + occhielli per servizio showroom (B)

**TECHNICAL FEATURES:**

- Ideal for use in the automotive and industrial field, CHARGEMATE is a battery charger with inverter technology that works as a buffer power supplier during the reprogramming of the electronic control unit
- It has a LCD screen which can display tension, current, charged Ah, charge status of the battery
- The most powerful on the market 12V / 140A (suitable for BMW, Land Rover etc.)
- Charge current: 3 ÷ 140A
- Charge tension: 12V
- Setting of the holding voltage 12.0 ± 15.0 with a 0.1 volts step
- Intended use: battery charger - power supplier
- 16mm<sup>2</sup> bipolar cable with safety Anderson connectors and pliers (A)
- Chargemate cables with Anderson type terminal + eyelets para el servicio de showroom (B)

**CARACTERÍSTICAS TÉCNICAS:**

- Ideal para el uso en el campo de la automoción e industrial, CHARGEMATE es un cargador de batería con tecnología inverter que funciona como proveedor de energía de respaldo de la unidad de control electrónico
- Tiene una pantalla LCD que puede mostrar tensión, corriente, Ah cargados, estado de carga de la batería
- El más potente del mercado 12V/140A (adecuado para BMW, Land Rover etc.)
- Corriente de carga: 3 ÷ 140A
- Tensión de carga: 12V
- Ajuste de la tensión de mantenimiento 12.0 ± 15.0 con un paso de 0.1 voltio
- Uso previsto: cargador de batería - proveedor de energía
- Cable bipolar de 16mm<sup>2</sup> con conectores Anderson de seguridad y alicates (A)
- Cables Chargemate con terminal tipo Anderson + ojales (B)

Corredo standard / Standard equipment / Equipamiento estandar





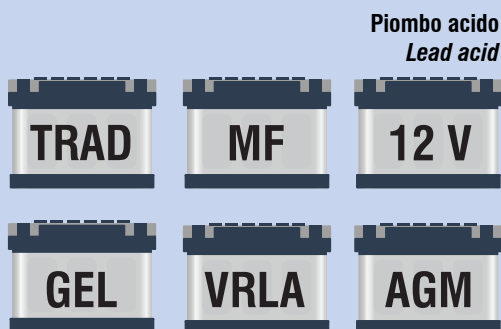

12V WET / VRLA / GEL / MF / AGM (START-STOP)  
LA/CA / LITHIUM LIFEPO4 (SMART LITHIUM)

# SMART

NUOVA GAMMA CARICABATTERIE  
NEW RANGE OF BATTERY CHARGERS



**IT** "SMART" NUOVA GAMMA  
DI CARICABATTERIE AUTOMATICI

- Aumentano la vita e lo spunto della batteria
- Elevate prestazioni di carica e mantenimento
- Ricaricano di batterie profondamente scariche
- Massima efficienza, minimo consumo energetico
- 100% automatici

**CARATTERISTICHE TECNICHE**

- > Multi-ciclo con microprocessore
- > Recupero, carica, mantenimento test batterie
- > Idoneo per tutte le batterie al piombo-acido e batterie al litio LiFePO4 (Mod. SMART LITHIUM)
- > Il dispositivo può rimanere sempre collegato alla batteria
- > Cablaggio a tenuta stagna permette un collegamento alla batteria comodo e veloce
- > 100% sicuro: 8 protezioni
- > Alimentazione: 220 ÷ 240V, 50 ÷ 60Hz
- > Resistente agli agenti atmosferici esterni IP 44
- > 3 anni garanzia

**CORREDO STANDARD**

- > Cavi di collegamento con connessioni "Superseal"



**EN** "SMART" IS THE NEW RANGE OF  
MULTI-CYCLE & AUTOMATIC BATTERY CHARGERS

- Preserve the battery life and power
- High charge performance and maintenance
- Recharge of deep discharged batteries
- Highest efficiency, lowest energy consumption
- 100% automatic

**TECHNICAL FEATURES**

- > Multi-cycle with microprocessor
- > Recovery, charge, maintenance and battery test
- > Suitable for all types of lead-acid batteries and LiFePO4 batteries (Mod. SMART LITHIUM)
- > The device can stay always connected to the battery
- > The water-proof wiring cable allows a fast and easy connection to the battery
- > 100% safe: 8 different protections
- > IP 44 Weatherproof
- > 3 year warranty

**STANDARD OUTFITS**

- > External cables with connections "Superseal"

**Corredo standard / Standard outfits**



- > Cavi di collegamento con connessioni "Superseal"
- > External cables with connections "Superseal"

ALGORITMO DI CARICA / CHARGING ALGORITHM

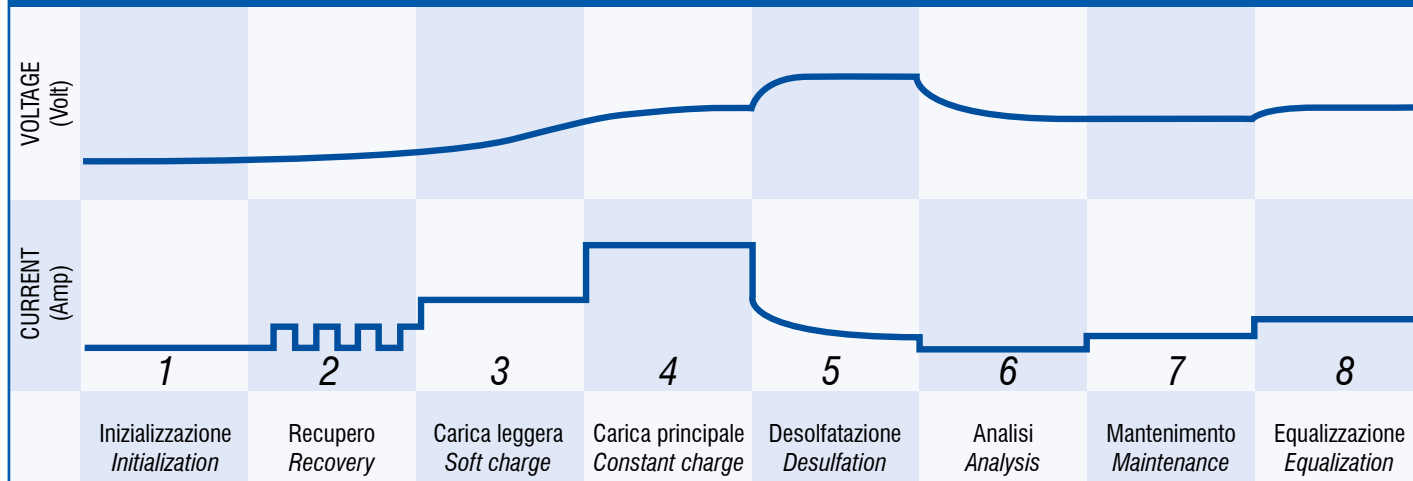

5 ANNI GARANZIA  
WARRANTY 5 YEARS  
GARANTIA 5 AÑOS  
GARANTIE 5 ANS  
5 JAHREN GARANTIE



Modelli disponibili Available models	SMART 200 Cod. 03.024.30	SMART 400 Cod. 03.024.31	SMART 1000 Cod. 03.024.32	SMART LITHIUM Cod. 03.024.33
<b>Volt</b>	6/12V	12V	12V	12V
<b>Capacità batterie Battery capacity</b>	3-100Ah	3-150Ah	3-200Ah	3-100Ah
<b>A max</b>	2	4	10	1,5
Piombo acido <b>Lead-Acid</b> (wet, gel, MF, AGM, VRLA)	✓	✓	✓	✓
Litio <b>Lithium</b> (Life PO4)	—	—	—	✓
Programmi di carica speciali <b>Special charging programs</b>	—	Auto&Moto+AGM Car&Bike+AGM	Auto&Moto+AGM Car&Bike+AGM	—
Modalità alimentazione <b>Power Supply Mode</b>	—	✓	✓	—
Algoritmo di carica – 8 passi <b>Charging algorithm – 8 Steps</b>	✓	✓	✓	✓
PROTEZIONI Corto circuito, inversione di polarità, sovraccarica e surriscaldamento <b>PROTECTIONS</b> Short circuit, polarity inversion, overcharging and overheating	✓	✓ + Compensazione temperatura + <b>Temperature Compensation</b>	✓ + Compensazione temperatura + <b>Temperature Compensation</b>	✓ + Polar Mode
	€ 56,00	€ 79,00	€ 118,00	€ 78,00

**DT31010**

Cod. 04.005.02

€ 169,<sup>00</sup>



**MULTIMETRO "IBRIDO"**

con pinza contagiri e sonda temperatura

**MULTIMETER "HYBRID"**

with rpm counter pliers and temperature probe

**MULTIMETRE "HYBRIDE"**

avec pince compte-tours et sonde température

**MULTIMETER HYBRID**

mit dem Drehzahlmesser und Temperaturfühler

**MULTÍMETRO "HÍBRIDO"**

con pinza cuentarrevoluciones y sonda temperatura

PROBES COMPLY TO NEW  
IEC61010-031:2008  
NORM VALID FROM  
01/03/2011

**KT2HYBRID**

Cod. 04.006.02

€ 267,<sup>00</sup>



IL KIT DIAGNOSI PROFESSIONALE PER L'ELETTRAUTO E IL MECCANICO DIAGNOSTICO.  
INCLUDE MULTIMETRO DT31010 E PINZA AMPEROMETRICA CBA 600

THE PROFESSIONAL CAR DIAGNOSTIC KIT FOR CAR ELECTRICIANS AND DIAGNOSTIC MECHANICS.  
IT INCLUDES DT31010 MULTIMETER AND AMPEROMETRIC PLIERS CBA 600

LE KIT DIAGNOSTIQUE PROFESSIONNEL POUR L'ÉLECTRICIEN VOITURES  
ET LE MÉCANICIEN DE DIAGNOSTIQUE.

IL INCLUE LE MULTIMÈTRE DT31010 ET LA PINCE AMPÈREMÉTRIQUE CBA 600

DAS PROFI SET FÜR AUTOELEKTRIKER UND DIAGNOSE MECHANIKER. UMFASST MULTITESTER  
DT31010 UND ZANGENSTROMMESSER CBA 600

EL KIT DIAGNÓSTICO PROFESIONAL PARA LOS ELECTRICISTAS DE AUTOMÓVILES  
Y LOS MECÁNICOS DIAGNÓSTICOS.

EL KIT INCLUYE EL MULTÍMETRO DT31010 Y ALICATES AMPEROMÉTRICOS CBA 600

**AT-605**

Cod. 04.009.01

€ 120,<sup>00</sup>



**Pinza amperometrica per misure di bassa corrente AT-605**

- ✓ Misure accurate a partire da 1mA (.001A)
- ✓ Ottimo utensile per testare la presenza di correnti parassite

**Premium Low Current Clamp Meter AT-605**

- ✓ Accurate measurements down to 1 mA (.001A)
- ✓ Great tool for parasitic currents detecting

**Pince ampèremétrique pour mesures de basse courant AT-605**

- ✓ Mesures précises à partir de 1 mA (0.001A)
- ✓ Instrument optimal pour tester la présence de courant parasite

**Medidor de corriente baja con abrazadera AT-605**

- ✓ Medidas exactas desde 1 mA (.001A)
- ✓ Gran herramienta para la prueba de corrientes parasitarias

**AT-607**

Cod. 04.009.02

€ 98,<sup>00</sup>

**600A AC/DC**

NEW 2017



**Pinza amperometrica**

**Ampereometric pliers**

**Pince ampèremétrique**

**Zangenstrommesser**

**Alicates amperométricos**

**AT-606**

Cod. 04.009.03

€ 78,<sup>00</sup>

NEW 2017



**Pinza amperometrica per correnti dispersive**

(risoluzione 0,001V - 0,001A) per multimetri

**Current clamp for dispersive currents**

(resolution 0,001V - 0,001A) for multimeters





**Pince ampèremétrique pour courants dispersifs**

(résolution 0,001V - 0,001A) pour multimètres

**Pinza amperométrica para corrientes dispersivas**

(resolución 0,001V - 0,001A) para multimetros



Modelli / Models Models / Modelle Modelos					
Misure effettuabili Tests that can be carried out Mesures executables Ausführbare Messungen Pruebas realizables	<b>DT 31010</b> Cod. 04.005.02	<b>AT 607</b> Cod. 04.009.02 KIT	<b>KT2</b> Cod. 04.006.02	<b>AT 605</b> Cod. 04.009.01	<b>AT 606</b> Cod. 04.009.03
Cambio scala automatico Change of scale / Changement d'échelle Skalen Wechsel / Cambio escala	✓	MANUAL	✓	MANUAL	MANUAL
Tensione (DC) / Voltage (direct current) Voltage (ampérage continu) Spannung (Gleichstrom) / Tension (DC)	1000V max	---	1000V max	600V max	---
Tensione (AC)/Voltage (alternate current) Voltage (ampérage alterné) Spannung (Wechselstrom)/Tension (AC)	1000V max	---	750V max	600V max	600V AC rms CAT III
Corrente (AC)/Current (alternate current) Ampérage (ampérage alterné) Strom (Wechselstrom)/Corriente (AC)	20A	600A	20A/600A	4A (0,001A) 40A (0,01A) 100A (0,1A)	20A (10mV/A) 100A (1mV/A)
Corrente DC DC Current / Ampérage DC DC Strom / Corriente DC	20A	600A	20A/600A	4A (0,001A) 40A (0,01A) 100A (0,1A)	20A (10mV/A) 100A (1mV/A)
MilliAmpere MilliAmpere / MilliAmpères MilliAmpere / MilliAmperios	✓	---	✓	✓	---
Resistenza Resistance / Résistance Widerstand / Resistencia	32 MOHM max	---	32 MOHM max	40 MOHM max	---
Prova diodi Diode test / Essai diodes Dioden Prüfung / Prueba diodos	✓	---	✓	✓	---
Temperatura Temperature / Température Temperatur / Temperatura	-20°C/+750°C	---	-20°C/+750°C	---	---
Ciri Motore/R.P.M./Tours Moteur Umdrehungen Motor Revoluciones por Minuto	0-9999 rpm	---	0-9999 rpm	---	---
Duty Cycle	0-100%	---	0-100%	5% ÷ 99%	---
Dwell	0-99%	---	0-99%	---	---
Tempo iniezione Injection time / Temps d'injection Einspritz Zeit / Tiempo de inyección	✓	---	✓	---	---
Frequenza Frequency / Fréquence Frequenz / Frecuencia	320Hz/32KHz	---	320Hz/320KHz	10Hz ÷ 200KHz	---
Custodia antiurto / Shock-proof case Protection contre les chocs Stoßfester Schutzkasten Estuche antichoque	✓	---	✓	---	---
Barra grafica analogica Analogue graphic display Barre graphique analogique Grafik Analoganzeige Pantalla gráfica analógica	✓	---	✓	---	---



LAMPADA A LED ULTRALUMINOSA

# Lampada sottocofano



ULTRA BRIGHT LED INSPECTION LAMP

## Under Bonnet Lamp

LÁMPARA DE INSPECCIÓN LED ULTRA BRILLANTE

## Lámpara bajo capò

**NEW!**  
**2018**

Cod. 05.073.26

€ 190,00

5W COB LED \*3, 1000Lumens

Controllo della modalità di illuminazione  
Lighting mode control  
Control modalidad de iluminación

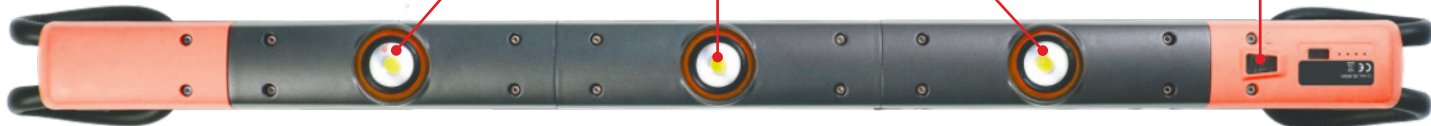

**Luminosità**  
Light output  
Potencia luminosa



**Temperatura di colore**  
Colour temperature  
Temperatura del color

3 lampade a led x 5W = 1000 lumen  
Temperatura di colore: 6000K

Luce bianca intensa

3 livelli di luminosità:

- Alto (3 lampade) - 1000 lumen
- Medio (2 lampade) - 675 lumen
- Basso (1 lampada) - 350 lumen

3x5W LEDs provide 1000 lumens  
light output

6000K colour temperature for bright  
white light

3 levels of light output:

- High (3 lamps) - 1000 lumens
- Med (2 lamps) - 675 lumens
- Low (1 lamp) - 350 lumens

3 lámparas led x 5W = 1000  
lúmenes

Temperatura de color de 6000K para  
una luz blanca brillante

3 niveles de potencia luminosa:

- Alto (3 lámparas) - 1000 lúmenes
- Med (2 lámparas) - 675 lúmenes
- Bajo (1 lámpara) - 350 lúmenes

Bracci estensibili fino a 1,75 m  
Expandable arms up to 1.75m  
Brazos extensibles hasta 1.7

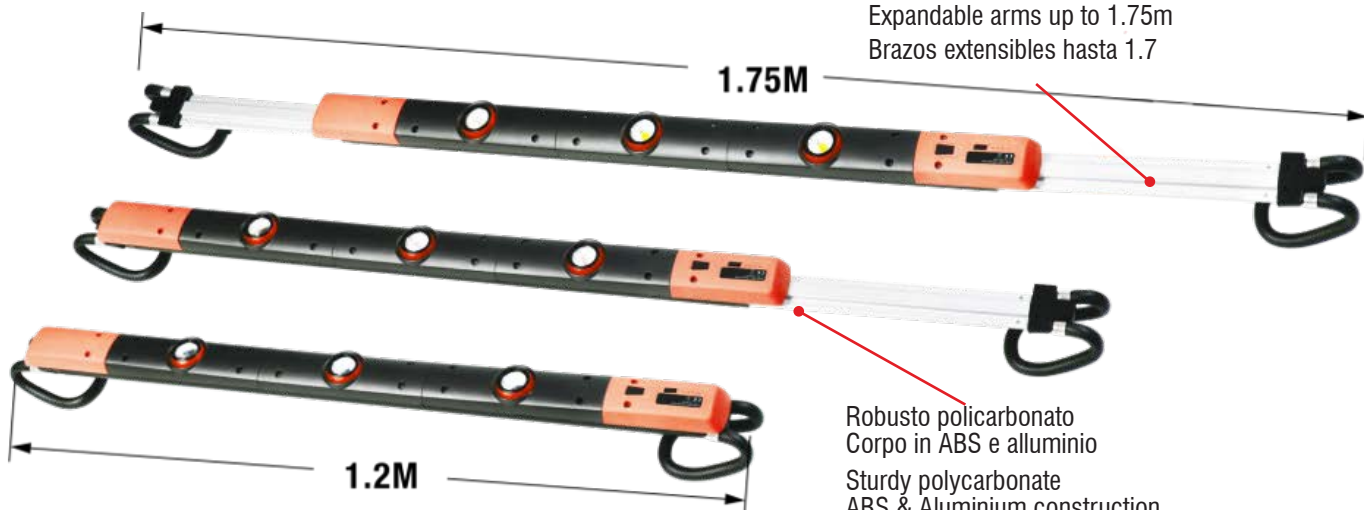

Robusto policarbonato  
Corpo in ABS e alluminio  
Sturdy polycarbonate  
ABS & Aluminium construction  
Policarbonato robusto  
Cuerpo en ABS y aluminio



**Bracci estensibili**  
Expandable arms  
Brazos extensibles



Le testine della luce ruotano indipendentemente per dirigere la luce proprio dove ne hai bisogno

Light heads pivot independently to direct light right where you need it

Los cabezales luminosos pivotan independientemente para dirigir la luz justo donde se necesita

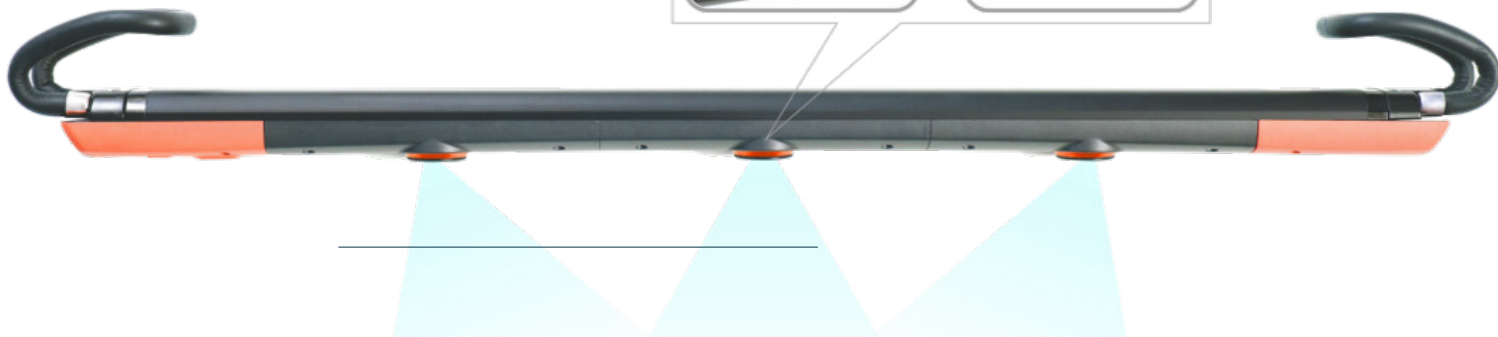
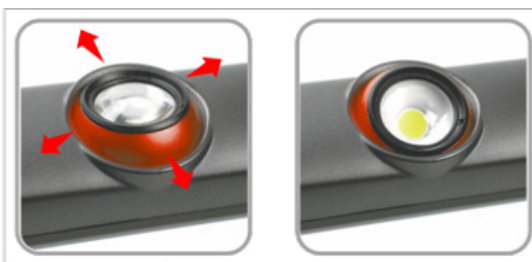

**Multi-angolo**  
Multi-angle  
Multiángulo



**Fascio luminoso**  
Beam angle  
Ángulo de haz

Testa regolabile a 40° per illuminare il vano motore esattamente dove serve

Illuminazione grandangolare a 60°

40° adjustable head to shine light on the engine bay exactly where it is required

60° wide angle illumination

Cabezal ajustable a 40° para iluminar el vano motor exactamente donde se requiere

Amplio ángulo de iluminación de 60°



Uscita USB 5V 2000mA  
USB Output 5V 2000mA  
Salida USB 5V 2000mA

Batteria a Li-Ion 3.7V 10400mAh  
3.7V 10400mAh Li-ion Battery  
Batería de iones de litio de 3.7V 10400mAh



**Tempo operativo**  
Operating time  
Tiempo de funcionamiento



**Tempo di carica**  
Charging time  
Tiempo de carga

Batteria ricaricabile a Li-ion 3.7V 10400mAh

Tempo operativo:  
3 lampade - 6 ore;  
1 lampada - 15 ore

Tempo di carica: 6,5 ore

Indicatore luminoso di stato della batteria

Rechargeable 3.7V 10400mAh Li-ion battery

Operating time:  
3 lamps - 6h;  
1 lamp - 15h

6,5h recharging time

Illuminated battery status indicator

Batería recargable de iones de litio de 3.7V 10400mAh

Tiempo de funcionamiento:  
3 lámparas - 6 h;  
1 lámpara - 15h

Tiempo de recarga 6,5h

Indicador de estado de la batería iluminado





- Regolabile in lunghezza (da 120 a 180cm)
- Ganci in nylon con ricopertura "soft"
- Caricabatterie automatici in dotazione (220V AC / 12V DC)
- Intensità: 600 lumen
- 3,7V 4400 mAh
- Lampada sganciabile

- Adjustable in length (from 120 to 180 cm)
- Nylon hooks with "soft" covering
- Equipped with automatic battery chargers (220V AC/12V DC)
- Intensity: 600 lumen
- 3,7V 4400 mAh
- Removable lamp

- Regulable en longitud (desde 120 hasta 180 cm)
- Ganchos de nylon con recubrimiento "soft"
- Recargabatería automático incluido (220V AC / 12V DC)
- Intensidad: 600 lumen
- 3,7V 4400 mAh
- Lámpara extraíble



Cod. 05.073.25T

€ 60,00

**Lampada U/V ricaricabile**  
**Rechargeable U/V lamp**  
**Lampara U/V recargable**



Batteria/Battery/Bateria Li-ion/Ion Litio 3,7V 2200mAh  
 Isolamento/Insulation/Aislamiento IP65  
 Completa di caricabatterie AC e da presa accendisigari 100/240 V AC  
 Complete with AC battery charger and cigarette lighter plug 100/240 V AC  
 Completa con cargador de batería AC y toma de encendedor de cigarillos 100/240 V AC  
 Occhiali/goggles/gafas  
 Funzioni/Functions/Funciones: 100% - 50% - SOS - OFF

Cod. 05.073.25TK

€ 120,00



HF01234yf

R134a

Cod. 05.073.24T

€ 32,00



**Torcia U/V a batteria**  
**U/V flashlight with batteries**  
**Lampara U/V de mano con baterias**

Torcia U/V a batteria 3x1,5V batterie incluse Occhiali Confezione: cartone	U/V flashlight with batteries 3x1,5V batteries (included) Goggles Packaging: cardboard	Lampara U/V de mano con 3 baterias 3x1,5V baterias (incluidas) Gafas Embalaje: carton
---	---	---

Cod. 05.073.24TK

€ 92,00



HF01234yf

R134a

**NEW!  
2018**

Cod. 05.073.27DIN

€ 75,00

**NUOVA LAMPADA A TECNOLOGIA COB (CHIP ON BOARD) LED  
NEW COB (CHIP ON BOARD) LED LAMPS FOR WORKSHOPS  
NUEVA LÁMPARA LED C.O.B. (CHIP ON BOARD) PARA TALLERES**



- Lampada a tecnologia COB (Chip on Board) LED
- 1\*5W COB e 1\*1W Torcia
- Alta potenza luminosità (450 lumen)
- Resistente a urti, lente in policarbonato ad alta trasparenza
- Batteria al litio da 3,7V - 3600 mAh
- 2 caricatori (12VDC da accendisigari e 100/240V AC)
- Ricarica completa: 3,5 ore
- Autonomia: 4 ore
- Base magnetica
- Rotazione: ± 90°
- Dotata di gancio estraibile
- Corpo in plastica gommata per una migliore presa
- Base di ricarica 100/240V 50Hz

- Latest LED technology: Chip on Board (COB)
- 1\*5W COB main light and 1\*1W torch light
- Strong light output (450 lumens)
- Durable shock resistant housing, hi-transparency polycarbonate lens
- Lithium battery: 3,7V - 3600 mAh
- Two battery chargers: 100/240V AC and 12VDC cigarette lighter
- Complete charging time: 3,5h
- Autonomy: 4h
- Magnetic base
- Flex function: ± 90°
- Removable hook
- Rubberized plastic body for better grip
- Charging base 100/240V 50Hz

- La última tecnología LED: Chip on Board (COB)
- 1 \* 5W COB luz principal y 1 \* 1W luz de la antorcha
- Fuerte producción de luz (450 lúmenes)
- Alojamiento durable, lente de policarbonato de alta transparencia
- Batería de litio: 3,7V - 3600 mAh
- Dos cargadores de batería: 100 / 240V AC y 12V CC del encendedor de cigarrillos
- Tiempo completo de carga: 3,5h
- Autonomía: 4 h
- Base magnética
- Función Flex: ± 90 °
- Gancho extraíble
- Cuerpo de plástico recubierto de goma para un mejor agarre
- Base de carga 100/240V 50Hz



**NEW!  
2018**

Cod. 05.073.13T

€ 38,00

**LAMPADA 3W COB LED + 5 LED FRONTALI  
3W COB + 5LED WORK LAMP  
LAMPARA 3W COB + 5 FRONTALES LED**



- Lampada 3W COB LED + 5 led frontali
- Batterie ioni di litio 3.7V 2400 mAh
- Luminosità: 220 lumen
- Pieghevole
- Base magnetica + magneti laterali
- Tempo di lavoro: 5-6 ore
- Tempo di carica: 5-6 ore
- 2 ganci
- Caricabatteria: 230V (mini USB) e DC

- 3W COB LED + 5 led work lamp
- Li-ion battery: 3.7V 2400 mAh
- Light output: 220 lumen
- Folding
- Magnetic base + side magnets
- Operating time: 5-6 hours
- Charging time: 5-6 hours
- Double hook
- Battery charger: 230V (mini USB) / DC

- Lámpara de trabajo 3W COB LED + 5 led
- Batería de iones de litio: 3.7V 2400 mAh
- Potencia luminosa: 220 lúmenes
- Base magnética plegable + imanes laterales
- Tiempo de funcionamiento: 5-6 horas
- Tiempo de carga: 5-6 horas
- Gancho doble
- Cargador de batería: 230V (mini USB) / DC

Cod. 05.073.20T

€ 49,00

**COB SLIM LAMPADA PORTATILE con batteria ricaricabile**  
**PORTABLE LAMP with rechargeable battery**  
**LÁMPARA PORTÁTIL con batteria recargable**



**HOT!**

- Batteria: Litio 3.7V 2600 mAh Li-ion
- Carica: 3 ore
- Intensità/durata: 3 ORE
- C.O.B. LED: 3 W
- 3 magneti
- 210 Lumen
- 1 Gancio
- Spessore: 9mm
- Torcia 18W
- Lithium battery: 3.7V 2600 mAh Li-ion
- Load: 3 hours
- Duration/Intensity: 3 hours
- C.O.B. LED 3 W
- 3 magnets
- 210 Lumen
- 1 Hook
- Thickness: 9mm
- Head lamp 18W
- Batería de litio: 3.7V 2600 mAh Li-ion
- Carga: 3 horas
- Duración/Intensidad: 3 horas
- C.O.B. LED 3 W
- 3 imanes
- 210 Lumen
- 1 Gancho
- Espesor: 9mm
- Lampara 18W



Cod. 05.073.08

€ 74,00



**LAMPADA PORTATILE RICARICABILE**  
**A 3 + 1 LED di alta potenza**

**RECHARGEABLE PORTABLE LED LAMP**  
**3 LED + 1 HIGH-POWER LED**

**LÁMPARA PORTÁTIL RECARGABLE**  
**DE 3 + 1 LED de potencia elevada**

Sistema di ricarica con tecnologia ad induzione (nessun contatto tra lampada e caricatore)

3 Led ad alta potenza (+ uno tipo torcia) foto A

ROBUSTA (classe di protezione III) foto B  
 IMPERMEABILE (classe isolamento IP 68) foto C

Autonomia media 3/4 ore  
 Dimensioni imballo 325x120x100 mm  
 Peso 0,9Kg

Recharging system with induction technology (no contact between the lamp and the charger)

3 high-power Led (+ 1 torch-like) Picture A

Strong (III protection class) picture B  
 WATER-PROOF (Insulation class IP 68) picture C

Average endurance ¾ hours  
 Packaging dimensions 325x120x100 mm  
 Weight 0,9Kg

Sistema de recarga con tecnología de inducción (ningún contacto entre la lámpara y el cargador)

3 Led de potencia elevada (+ 1 tipo antorcha) Foto A

Sólida (clase de protección III) foto B  
 IMPERMEABLE (clase aislamiento IP 68) foto C

Autonomía 3/4 horas  
 Dimensiones embalaje 325x120x100 mm  
 Peso 0,9Kg

Cod. 05.073.13DIN

€ 42,00

**Lampada magnetica orientabile con batterie al litio**  
**Orientable magnetic lamp with lithium batteries**  
**Lámpara magnética orientable con baterías de litio**



Lampada COB 21+5 Led, 200 lumen  
 Base magnetica rotante  
 Gancio  
 Batterie Li-ion  
 Caricabatterie 100+240V 50/60Hz

COB Lamp 21+5 Led, 200 lumen  
 Rotating magnetic base  
 Hook  
 Li-ion batteries  
 Battery charger 100+240V 50/60Hz

Lámpara COB 21 + 5 LED, 200 lúmenes  
 Base magnética rotativa  
 Gancho  
 Baterías de ion-litio  
 Cargador de batería 100+240V 50/60Hz



Cod. 05.073.23

€ 96,<sup>00</sup>



HOT!

**FARO A LED (COB) DA 20W**  
con batterie al litio ricaricabili

**20W LED COB HEADLIGHT**  
with rechargeable lithium batteries

**Faro LED COB de 20W**  
con baterías de litio recargables



**Caratteristiche tecniche:**

Batterie al litio da 7,4V 4400mAh  
Isolamento: IP65  
Autonomia: >4h  
Luminosità: 2400 lumen  
Alimentatori: 90=265V AC 8,4V 500mA  
Caricatore da presa: 12-24V DC  
Peso: 2,5kgs  
Dimensioni: 111x130x205mm

**Technical features:**

Lithium batteries 7,4V 4400mAh  
Insulation: IP65  
Autonomy: >4h  
Brightness: 2400 lumen  
Power supply: 90=265V AC 8,4V 500mA  
Power Charge: 12-24V DC  
Weight: 2,5kgs  
Dimensions: 111x130x205mm

**Características técnicas:**

Baterías de litio 7,4V 4400mAh  
Aislamiento: IP65  
Autonomía: > 4h  
Brillo: 2400 lumen  
Fuente de alimentación: 90=265VAC 8,4V 500mA  
Cargador de corriente: 12-24V DC  
Peso: 2,5kgs  
Dimensiones: 111x130x205mm

La nuova tecnologia COB (Chip On Board) led finalmente accessibile a tutti per la casa - l'hobby - l'auto

NEW COB (chip on board) led LAMPS FOR WORKSHOPS finally available for everyone for home - hobby - car

NUEVAS LÁMPARAS COB (Chip On Board) LED para TALLERES finalmente disponibles para todos para el hogar - hobby - coche

Cod. 05.073.22

€ 8,<sup>20</sup>

**COB LED LAMP**



Cod. 05.073.21

€ 7,<sup>20</sup>

**COB PEN LIGHT**



HOT!

HOT!



NEW!  
2018



Cod. 05.073.28

€ 28,<sup>00</sup>

LAMPADA A LUCE SOLARE DA PARETE,  
CON SENSORE DI MOVIMENTO (DA ESTERNO)

SUNLIGHT LAMP WITH MOTION SENSOR,  
WALL MOUNTED (OUTDOOR)

LÁMPARA DE LUZ SOLAR CON SENSOR DE MOVIMIENTO,  
MONTADA EN PARED (PARA USO EN EXTERIORES)

**DATI TECNICI:**

- Pannello solare da 5,5V/0,6W/  
Efficienza 17%
- Batteria al litio 3,7V/1800mAh
- Rileva presenza di persone da 3  
a 6mt
- Luminosità: 450 lumen
- Potenza: COB LED 10W
- Grado di isolamento: IP65
- Dimensioni: 153x105x49mm
- Peso: 237gr

**TECHNICAL FEATURES:**

- Solar panel 5.5V / 0.6W / 17%  
efficiency
- 3.7V / 1800mAh lithium battery
- It detects the presence of people  
from 3 to 6mt
- Brightness: 450 lumens
- Power: COB LED 10W
- Degree of insulation: IP65
- Dimensions: 153x105x49mm
- Weight: 237gr

**DATOS TÉCNICOS:**

- Panel solar de 5.5V / 0.6W / 17%  
de eficiencia
- Batería de litio 3.7V / 1800mAh
- Detecta la presencia de personas  
de 3 a 6 mt
- Luminosidad: 450 lúmenes
- Potencia: COB LED 10W
- Grado de aislamiento: IP65
- Dimensiones: 153x105x49mm
- Peso: 237gr

NEW!  
2018



Cod. 05.073.29

€ 34,<sup>80</sup>

LAMPADA FRONTALE  
CON BATTERIE RICARICABILI A IONI DI LITIO

FRONT LAMP  
WITH RECHARGEABLE LITHIUM ION BATTERIES

LÁMPARA FRONTAL  
CON BATERÍAS RECARGABLES DE IONES DE LITIO

**DATI TECNICI:**

- 5W di potenza lampada frontale
- 3W di potenza luce posteriore
- 4 modalità di regolazione: lampada  
frontale (100%, 50%, 25%, OFF)
- Autonomia: 100% 2,5-3h; 50%  
5-7h; 25% >10h

**Principali applicazioni**

- Settore "bike"
- Settore trekking e climbing
- Cantieristica in genere
- Protezione civile
- Antinfortunistica

**TECHNICAL FEATURES:**

- 5W of power - front lamp
- 3W of power - rear light
- 4 adjustment modes: front lamp  
(100%, 50%, 25%, OFF)
- Autonomy: 100% 2.5-3h; 50%  
5-7h; 25% > 10h

**Principali applicazioni**

- Bike sector
- Trekking and climbing sector
- Building industry in general
- Civil protection
- Accident prevention

**DATOS TÉCNICOS:**

- 5W de potencia - luz delantera
- 3W de potencia - luz trasera
- 4 modos de ajuste: luz delantera  
(100%, 50%, 25%, OFF)
- Autonomía: 100% 2.5-3h; 50%  
5-7 h; 25% > 10h

**Principali aplicaciones**

- Sector "Bicicleta"
- Sector trekking y escalada
- Industria de construcción en  
general
- Protección civil
- Prevención de accidentes



Luce con zoom, angolo regolabile  
Twist to zoom, adjustable angle  
Torcer para hacer zoom, ángulo ajustable



Cavo di estensione  
Extension cable  
Cable de extensión



Vano batterie separabile con luce COB (rossa/bianca)  
Detachable battery box with COB light (red/white)  
Caja de baterías desmontable con luz COB (roja / blanca)



Luce di sicurezza rossa COB  
Red COB safety light  
Luz de seguridad roja COB



CAVI DI SOCCORSO JUMPER CABLES CABLES DE SOCORRO		A AMPERE	SECTION SECTION SEZIONE	LENGTH LONGITUD LUNGHEZZA	APPLICATION Uso Uso	NORMS NORMAS NORME
 <p>COPPER PLATED</p>	<p>Cod. 05.060.02</p> <p>€ 24,00</p>	350A	25mm <sup>2</sup>	3,5mt	Auto - Camper veicoli comm.li Cars - campers commercial vehicles Coches, caravanas, vehículos comerciales	TÜV GS CE Zip bag Borsa zip
	<p>Cod. 05.060.03</p> <p>€ 34,00</p>	480A	35mm <sup>2</sup>	4,5mt	Auto - Camper veicoli comm.li - autocarri Cars - Campers commercial vehicles trucks Coches, caravanas, vehículos comerciales, camiones	TÜV GS CE Borsa zip Zip bag
 <p>PLACCATO IN RAME</p>	<p>Cod. 05.060.04</p> <p>€ 165,00</p> <p>PURE 100% COPPER RAME PURO 100%</p>	1000A	50mm <sup>2</sup>	5mt	Movimento terra autocarri / bus Earth-moving machines trucks / buses Máquinas para movimiento de tierra, camiones / autobuses	CE Borsa zip Zip bag

Cod. 05.060.00 € 48,00

**EVERSMART**



**CAVO DI SOCCORSO ELETTRONICO  
PROTETTO CONTRO INVERSIONI E CORTI CIRCUITI**  
(BREVETTATO) CONFORME NORMATIVA CE e SAE.

**INTELLIGENT BOOSTER CABLE  
AGAINST INVERSIONS AND SHORT CIRCUITS**  
(PATENTED). IN CONFORMITY WITH CE AND SAE STANDARDS.

**CABLE DE SOCORRO ELECTRÓNICO  
PROTEGIDO CONTRA LAS INVERSIONES  
DE POLARIDAD Y LOS CORTOCIRCUITOS**  
(CON PATENTE) DE CONFORMIDAD CON LAS NORMATIVAS CE Y SAE

Cod. 03.000.42 € 95,00

**COMPRESSORI D'ARIA A 12V  
12 V AIR COMPRESSORS**

**HOT!**



Compressore d'aria 12 V 30 A, massima pressione 10,3 Bar  
Idoneo per vetture, camper e furgoni

12 V 30 A air compressore, maximum pressure 10.3 Bar  
Suitable for cars, camping vans and commercial vans

**ADATTATORE-ALIMENTATORE  
da presa accendi sigari  
ADAPTER-POWER SUPPLY  
for cigar lighter socket**

Cod. 05.096.04

€ 6,40



INPUT 12V - 24V DC  
DUAL OUTPUT:  
5 V DC = 2,1 A  
5 V DC = 1 A

Cod. 05.096.03 € 15,50



**Voltmetro digitale da auto  
Digital voltmeter for vehicles**

Permette un controllo costante dello stato della batteria attraverso la presa accendisigari  
Confezione in blister

It allows to check constantly on the battery status through the cigar lighter socket  
Supplied in blister package





**NEW!  
2018**

Cod. 05.084.21

€ 68,<sup>00</sup>

**KIT CRICCO IDRAULICO 2 TON  
PER PRONTO INTERVENTO**  
con ferma ruote e tappetino, guanti e valigia di trasporto

**2 TON HYDRAULIC JACK  
FOR EMERGENCY USE**

with wheel stops and mat, gloves and transport case

**GATO HIDRÁULICO DE 2 TONELADAS  
PARA USO DE EMERGENCIA**

con bloques de ruedas y alfombrilla, guantes y maletín de transporte



- Idoneo per uso privato
- Peso netto/lordo: 9,55/10,96kg
- Dimensioni imballo: 50 x 23 x 16 cm
- Suitable for personal use
- Peso neto/bruto: 9,55/10,96kg
- Dimensiones del embalaje: 50 x 23 x 16 cm

- Adecuado para uso privado
- Net/gross weight: 9,55/10,96kg
- Package dimensions: 50 x 23 x 16 cm

**Sistemi di lavaggio/pulizia - Washing/cleaning systems - Sistemas de lavado y limpieza**



Cod. 05.075.08

€ 39,<sup>50</sup>

**Pistola lavaggio motori**  
**Engines' washer gun**  
**Pistola de limpieza para motores**

Può lavorare anche con detergenti petroliferi per lavaggi di motori auto, camion, moto e macchine operatrici  
2 ugelli in dotazione

It can work also with oil-rich cleansing liquids for washing vehicle, truck, motorbikes and operating machinery's engines  
Equipped with 2 nozzles

Puede funcionar también con líquidos de limpieza ricos en petróleo para el lavado de vehículos, camiones, motocicletas y motores de maquinaria  
Equipado con 2 boquillas



Cod. 05.075.09

€ 76,<sup>00</sup>

**Pistola spara schiuma**  
**Foam nebulizer gun**  
**Pistola nebulizadora de espuma**

Utilizzabile con vari prodotti di lavaggio  
Produce rapidamente un manto schiumoso per superfici da lavare

It can be used with different cleansing products  
It quickly spreads cleansers evenly to adhere to surfaces which need to be cleaned

Se puede utilizar con diferentes productos de limpieza  
Propaga rápidamente y uniformemente los limpiadores para que adhieran a superficies que deben ser limpiadas



Cod. 03.000.49

€ 36,<sup>00</sup>

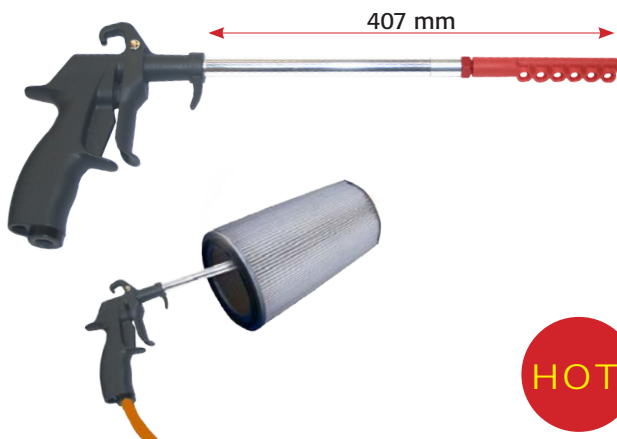

**PISTOLA DI SOFFIAGGIO CON 6 UGELLI LATERALI**  
per pulizia condotti, filtri aria veicoli commerciali, fuoristrada, macchine agricole.  
Lunghezza utile: 16" (407mm)

**BLOW GUN WITH 6 LATERAL NOZZLES**  
for the cleaning of ducts and air filters on commercial vehicles, off-road vehicles, agricultural machinery.  
Working Length: 16" (407mm)

**PISTOLA DE SOPLADO CON 6 BOQUILLAS LATERALES**  
para la limpieza de conductos y filtros de aire en los vehículos comerciales, vehículos todo terreno, maquinaria agrícola.  
Longitud de trabajo: 16" (407mm)

**HOT!**



Cod. 05.075.05

€ 139,00

**ATTREZZATURE PER IL RIPRISTINO DELL'EFFICIENZA  
DEI FILTRI ANTIPARTICOLATO (FAP-DPF)**

**CLEANING AND REGENERATION SERVICE KIT  
FOR CLOGGED FAP-DPF.**

**KIT DE LIMPIEZA PARA LA REGENERACIÓN  
DE FILTROS DE PARTÍCULAS (FAP-DPF)**

**KIT DE NETTOYAGE POUR RETABLER  
LE RENDEMENT DES FILTRES À PARTICULES**

**A**

**DPF FLUSH KIT  
CHE COS'È?**

Specifica attrezzatura funzionante con aria compressa progettata per la pulizia dei filtri antiparticolato degli autoveicoli diesel. Corredata di semplici e facili sonde intercambiabili che si possono utilizzare su ogni tipo e modello di filtri antiparticolato.

**DPF FLUSH KIT  
WHAT IS IT?**

Compressed-air gear for cleaning diesel particulate filters. Includes easy-to-use interchangeable probes suitable for use with every type and model of DPFs.

**DPF FLUSH KIT  
¿QUÉ ES?**

Instrumento de aire comprimido diseñado para la limpieza de los filtros antipartículas en los vehículos diesel.

Equipada con sondas intercambiables de fácil utilización adecuadas para todo tipo y modelo de filtres antipartículas.

**DPF FLUSH KIT  
QU'EST-CE QUE C'EST ?**

Équipements spécifiques qui fonctionnent avec air comprimé, conçu pour le nettoyage des filtres à particules dans les voitures diesel.

Doté de sondes interchangeables rapidement qui peut être utilisé sur tous les modèles de filtres à particules.

**B**

**DPF RINSE**

**LIQUIDO DI RISCIAQUO FAP  
CHE COS'È?**

Liquido specifico di risciacquo dopo la pulizia dei filtri antiparticolato diesel. Grazie alla sua particolare formulazione chimica, questo prodotto è in grado di agire in profondità nel nido d'ape all'interno del filtro antiparticolato, lasciandolo pulito dai residui carboniosi e fuliggine, facilitando l'operazione di rigenerazione del filtro.

**SOLUTION WHAT IS IT?**

Special rinse solution for DPFs. Thanks to its chemical formula, this product allows a deep rinse of the porous honeycomb DPF structure, thus removing any particulate matter and soot residue and easing filter regeneration..

**LÍQUIDO PARA ENJUAGUE FAP  
¿QUÉ ES?**

Liquido de enjuague después de la operación de limpieza de los filtros antipartículas diesel. Gracias a su específica formulación química, este producto actúa en profundidad en la estructura en forma de nido de abeja del filtro, para dejar el mismo limpio de todo residuo de carbonilla y hollín y facilitar la operación de regeneración del filtro.

**LIQUIDE DE RINÇAGE  
QU'EST-CE QUE C'EST ?**

Liquide de rinçage après nettoyage des filtres à particules diesel. Grâce à sa formulation chimique, cette produit agit sur la structure alvéolaire des filtres à particules; toutes les particules de suie, les cendres, les résidus et autres éléments polluants accumulés dans le filtre à particules sont détachés et la opération de régénération est simplifiée.



Cod. 05.075.06

€ 44,00

**C**

**DPF FLUSH**

**LIQUIDO DI PULIZIA FAP  
CHE COS'È?**

Liquido detergente non infiammabile, privo di metalli in sospensione, specifico per la pulizia dei filtri antiparticolato diesel. Grazie alla sua particolare formulazione chimica, questo prodotto è in grado di agire in profondità nel nido d'ape all'interno del filtro antiparticolato rimuovendo con facilità i residui carboniosi e fuliggine che ostruiscono il normale passaggio dei fumi di scarico del motore e ripristinando il funzionamento dell'intero sistema di scarico.

**CLEANSING DPF SOLUTION  
WHAT IS IT?**

Non-inflammable cleaning solution, suspended metals free, for DPFs. Thanks to its chemical formula, this product allows a deep rinse of the porous honeycomb DPF structure, thus removing any particulate matter and soot residue and easing the functioning of the whole exhaust emission system.

**LÍQUIDO DE LIMPIEZA FAP  
¿QUÉ ES?**

Liquido detergente no inflamable, sin partículas en suspensión, para la limpieza de los filtros antipartículas diesel. Gracias a su específica formulación química, este producto actúa en profundidad en la estructura en forma de nido de abeja del filtro, para remover fácilmente todo residuo de carbonilla y hollín que pueda obstruir el pasaje de los humos del tubo de escape del motor y restablecer el correcto funcionamiento del sistema de escape.

**LIQUIDE DE NETTOYAGE FAP  
QU'EST-CE QUE C'EST ?**

Fluide de nettoyage ininflammable, sans métaux en suspension, spécifique pour le nettoyage des filtres à particules diesel. Grâce à sa formulation chimique, cette produit agit sur la structure alvéolaire des filtres à particules. Toutes les particules de suie, les cendres, les résidus et autres éléments polluants qui obstruent le passage des gaz d'échappement sont détachés, et le bon fonctionnement du système d'échappement est rétabli.



Cod. 05.075.07

€ 46,00

**PROCEDURA:**

1. Lavaggio con liquido rosso (05.075.07) attraverso foro sensore di pressione DPF (FAP)
2. Risciacquo con liquido blu (05.075.06)
3. Rimontaggio sensore
4. Rigenerazione DPF (FAP) attraverso prova su strada
5. Reset spia DPF (FAP) con apparecchio autodiagnostico (non fornito).

Col kit basic si possono realizzare fino a 6 trattamenti.

**PROCEDURE:**

1. Washing phase with red liquid (05.075.07) through the DPF (FAP) pressure sensor's hole
2. Rinsing with blue liquid (05.075.06)
3. Reassembly of the sensor
4. DPF (FAP) Regeneration by test on the road
5. Reset of the DPF (FAP) warning light with an auto-diagnosis device (not supplied)

With the basic kit, it is possible to perform up to 6 treatments.

**PROCÉDURE:**

1. Phase lavage avec liquide rouge (05.075.07) à travers du trou du capteur de pression DPF (FAP)
2. Rinçage avec liquide bleu (05.075.06)
3. Remontage du capteur
4. Régénération DPF (FAP) par des tests sur le route
5. Reréglage du voyant DPF (FAP) avec un dispositif d'autodiagnostic (non fourni)

Avec le kit de base, il est possible d'effectuer jusqu'à six traitements.

**PROCEDIMIENTO:**

1. Fase de lavado con liquido rojo (05.075.07) a través del hoyo de sensor de presión DPF (FAP)
2. Enjuagar con liquido azul (05.075.06)
3. Remontaje del sensor
4. Regeneración DPF (FAP) mediante la prueba en la carretera
5. Reajustar la luz de advertencia DPF (FAP) con un dispositivo de auto-diagnóstico (no suministrado)

Con el kit básico, es posible realizar hasta 6 tratamientos.

**VASCHE ULTRASUONI  
SERIE CK-EXPORT**
**ULTRASONIC WASHERS BAÑOS DE ULTRASONIDOS  
CK-EXPORT SERIES  
SERIE CK-EXPORT**

## SERIE CK-EXPORT CK-EXPORT SERIES

**I CAMPI DI UTILIZZO:**

- Laboratori di meccanica di precisione (lavaggio minuterie)
- Laboratori di elettronica per lavaggio circuiti stampati
- Autofficine e specialisti iniezione benzina e diesel per pulitura carburatori, elettroiniettori, piccola minuteria meccanica, indotti, statori ecc.
- Carrozzerie per pulizie pistole di verniciatura

**FIELDS OF APPLICATION:**

- Precision mechanics work-shops
- Electronic laboratories for washing printed circuits
- Car repair shops and specialist shops for fuel and diesel injection parts and for cleaning carburetors, electric injectors, small mechanic parts, armatures, stators, etc.
- Workshops for painting guns cleaning

Modelli disponibili Available models	CK 2 Cod. 02.009.15	CK 5 02.009.13	CK 6 02.009.16	CK 9 02.009.17	CK 13 02.009.24	CK 27 02.009.25
Dimensioni vasca Tank size (mm)	150x140x100	240x140x100	300x155x150	300x240x150	330x300x150	500x295x200
Dimensioni esterne (mm) External size (mm)	180x170x240	270x170x240	330x170x310	330x270x310	360x330x310	530x330x360
Capacità (lt.) Tank capacity (lt.)	2	3	6	9,5	13	27
Potenza ultrasuoni Ultrasound power (W)	60W	120W	180W	240W	360W	600W
Frequenza standard (KHz) Standard frequency (KHz)	40	40	40	40	40	40
Alimentazione Power Supply	220 V 50/60 Hz	220 V 50/60 Hz	220 V 50/60 Hz	220 V 50/60 Hz	220 V 50/60 Hz	220 V 50/60 Hz
Potenza riscaldamento (W) Heating power (W)	100W	100W	300W	300W	400W	500W
Cestello Basket	✓	✓	✓	✓	✓	✓
Rubinetto di scarico Discharge valve	-	-	-	✓	✓	✓
	€ 209,00	€ 330,00	€ 570,00	€ 692,00	€ 969,00	€ 1.380,00

**Cod. 02.000.43**
**€ 59,00**

 liquido 5lt  
per vasca ultrasuoni 5411

 5lt of washing liquid  
for ultrasounds tank 5411

**Max diluizione al 10% (90% acqua)**
**Max 10% dilution (90% water)**



VASCHE ULTRASUONI  
SERIE CK-EXPORT

ULTRASONIC WASHERS  
CK-EXPORT SERIES

BAÑOS DE ULTRASONIDOS  
SERIE CK-EXPORT

**NUOVA SERIE LAVATRICI AD ULTRASUONI INDUSTRIALI**  
**NEW SERIES OF ULTRASONIC WASHERS**  
**NUEVA SERIE DE BAÑOS DE ULTRASONIDOS**

**I CAMPI DI UTILIZZO:**

- Applicazioni settore auto: lavaggio testate, motori, cerchi in lega, particolari metallici di medie dimensioni.
- Utilizzare solo detersivi a base acquosa a temperatura  $\geq 70^\circ$
- Cestello di lavaggio incluso

**FIELDS OF APPLICATION:**

- Applications automotive industry: washing engine cylinder heads, alloy wheels, metal parts of medium size.
- Use only water-based detergents at temperatures  $\geq 70^\circ$
- Washing basket included



**ACCESSORI A RICHIESTA**  
**ACCESSORIES ON DEMAND**

**COPERCHI PER MODELLI - LIDS FOR MODELS**  
• CK800 / CK2000 / CK2400 CK3600 / CK4800

Modelli disponibili / Available models	CK 800 Cod. 02.009.22	CK 2000 02.009.23	CK 2400 02.009.18	CK 3600 02.009.19	CK 4800 02.009.20	CK 6000 02.009.21
Dimensioni vasca / Tank size (mm)	450x350x300	750x400x400	750x550x500	1000x550x560	1200x600x600	1400x800x700
Dimensioni esterne (mm) External size (mm)	770x490x740	1100x500x740	1200x780x820	1180x800x900	1380x950x950	1700x980x960
Capacità (lt.) Tank capacity (lt.)	45	120	200	300	430	780
Potenza ultrasuoni Ultrasound power (W)	0,8Kw	2Kw	2,4Kw	3,6Kw	4,8Kw	6,0Kw
Frequenza standard (KHz) Standard frequency (KHz)	28	28	28	28	28	28
Alimentazione Power Supply	400 V 50Hz 3 phases	400 V 50Hz 3 phases	400 V 50Hz 3 phases	400 V 50Hz 3 phases	400 V 50Hz 3 phases	400 V 50Hz 3 phases
Potenza riscaldamento (W) Heating power (W)	2 Kw	6 Kw	6 Kw	9 Kw	9 Kw	12 Kw
Cestello incluso / Basket included	✓	✓	✓	✓	✓	✓
Rubinetto di scarico incluso Discharge valve included	✓	✓	✓	✓	✓	✓
	€ 3.670,00	€ 6.240,00	€ 8.700,00	€ 12.000,00	€ 16.800,00	€ 24.500,00



**HOT!**

**Cod. 03.036.17**

**€ 198,00**

Vasca lavaggio da 75lt - incluso pennello  
75lts Cleaning tank - brush included  
Bac de Nettoyage de 75lt - brosse compris  
tanque de lavado de 75lts - cepillo incluido

Con pompa elettrica / with electric pump / Con bomba electrica  
(230V 50Hz)

Dimensioni imballo / Packaging dimensions / Dimension del embalaje  
790x550x320mm

Peso / Weight / Poids  
28 kgs

**Vendita abbinata**  
**Combined sale**  
**Venta conjunta**

**Cod. 02.000.96**

**€ 150,00**

25lt liquido  
per vasca 03.036.17  
diluizione al 50%

25lt liquid  
for tank 03.036.17  
dilution 50%  
in water



**Attrezzature per la refrigerazione/condizionamento**

**Refrigeration/air conditioning equipment**

**Equipo de refrigeración y aire acondicionado**

**Kit cercafughe per impianti A/C**

(R134-HFO1234yf) e refrigerazione con miscela N2-H2 (95%/5%) e cercafughe elettronico per H2

**Leak detector kit for A/C**

(R134-HFO1234yf) and refrigeration systems with a N2-H2 mix (95%/5%) and electronic H2 leak detector

**Kit detector de fugas para sistemas de A/A**

(R134-HFO1234yf) y sistemas de refrigeración con una mezcla de N2-H2 (95%-5%) y detector electrónico de fugas H2

**HOT!**

**Cod. 01.000.225**

**€ 728,00**

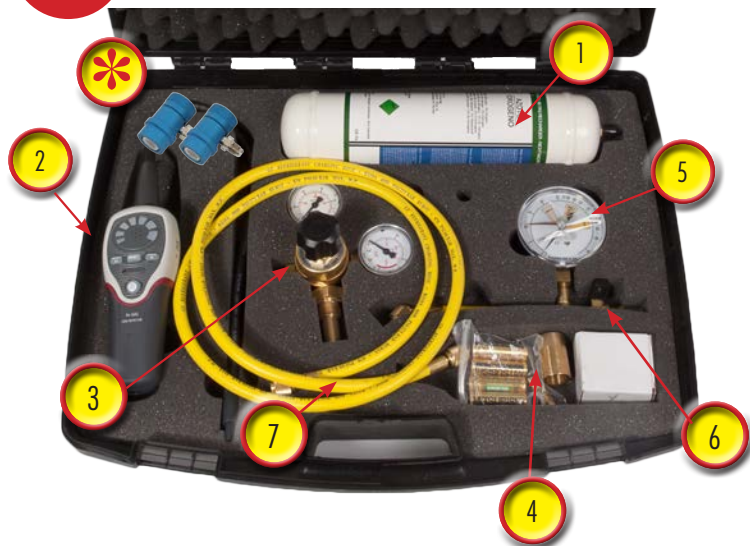

**Cod. 01.090.08**

**€ 385,00**

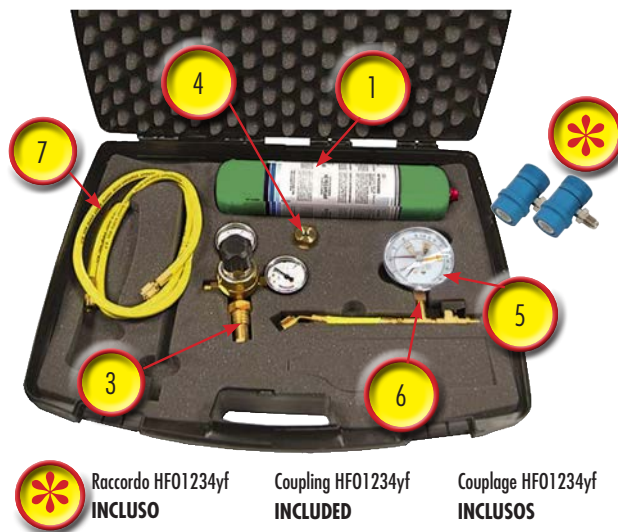

 **Raccordo HFO1234yf INCLUSO**

**Coupling HFO1234yf INCLUDED**

**Couplage HFO1234yf INCLUSOS**

**Il kit include:**

- |                                      |                           |
|--------------------------------------|---------------------------|
| 1. Bombola per 950cc N2-H2           | 4. Riduttore per bombola  |
| 2. Cercafughe per H2 (2gr./annuo)    | 5. Manometro doppia scala |
| 3. Regolatore di pressione (300 bar) | 6. Raccordo LP R134a      |
|                                      | 7. Tubo di collegamento   |
|                                      | 8. Raccordo LP (HFO)      |

**The kit includes:**

- |                                       |                       |
|---------------------------------------|-----------------------|
| 1. 950cc N2-H2 tank                   | 4. Tank adaptor       |
| 2. Leak detector for H2 (2gr./yearly) | 5. Double scale gauge |
| 3. Pressure regulator (300 bars)      | 6. LP R134a coupling  |
|                                       | 7. Connection hose    |
|                                       | 8. LP HFO coupling    |

**El kit incluye:**

- |   |                          |
|---|--------------------------|
| 1. Tanque de 950cc N2-H2                | 4. Adaptador del tanque  |
| 2. Detector de fugas de H2 (2gr./anual) | 5. Calibre Doble escala  |
| 3. Regulador de presión (300 bares)     | 6. Acoplamiento BP R134a |
|   | 7. Manguera de conexión  |
|   | 8. Acoplamiento B.P. HFO |

**Cod. 01.000.202**

**Cod. 01.000.202**

**€ 343,00**

Cercafughe Elettronico H2 sensibilità 2gr./annuo

Electronic H2 Leak detector Sensitivity 2gr./yearly

Detector de fugas electronico de H2 Sensibilidad 2gr./anual



**Cod. 01.090.07**

**€ 44,00**



**Cod. 01.001.91**

**€ 119,00**

**Kit "B" BASIC**

Lampada u/v 50W 12V, 12 additivi monodose in siringa, occhiali e valigetta in ABS

U/V lamp 50W 12V, 12 single-dose additives in syringe, goggles and ABS case



**Cod. 01.000.79**

**€ 85,00**

Lampada u/v 50W 12V, occhiali e valigetta in ABS

U/V lamp 50W 12V, goggles and ABS case





Cod. 01.000.100

€ 138,00



>Cercafughe elettronico a LED, per tutti i tipi di refrigerante  
>LED electronic leak detector for all refrigerants

Cod. 01.000.203

€ 375,00

Cercafughe Elettronico a LED per tutti i tipi di refrigerante, incluso HFO1234YF, certificati SAE 2791

Refrigerant gas leak detector detects all CFC, HFC, HCFC refrigerants, including HFO1234YF, certified SAE 2791



Art. 15.1CR

Coppia attacchi rapidi per impianti R134 con rubinetto  
Special rapid couplings for R134 systems with taps.



Cod. 01.000.08

Made in EU € 78,00

Cod. 01.000.08IMP

imported € 41,00

Coppia attacchi rapidi per HFO1234YF  
Special rapid couplings for HFO1234YF

Cod. 01.000.168

Made in EU € 94,00

Cod. 01.000.168IMP

imported € 49,00

Cod. 01.090.04

€ 90,00

> Gruppo manometrico a 4 vie con 3 tubi L=150mm (rosso, blu, giallo) e valigetta di trasporto (scale R22-R134-R407c-R410a)  
> Four-way manometric group with 3 hoses L=150mm (red, blue, yellow) and transport case (for gas R22-R134-R407c-R410a)  
> Grupo manométrico de cuatro vías con 3 mangueras L = 150mm (rojo, azul, amarillo) y caja de transporte (para gas R22-R134-R407c-R410a)



Cod. 01.090.00

€ 90,00

> Gruppo manometrico a 4 vie con 3 tubi L=150mm (rosso, blu, giallo) e valigetta di trasporto (scale R22-R134-R404c-R407a)  
> Four-way manometric group with 3 hoses L=150mm (red, blue, yellow) and transport case (for gas R22-R134-R404c-R407a)

> Grupo manométrico de cuatro vías con 3 mangueras L = 150mm (rojo, azul, amarillo) y caja de transporte (para gas R22-R134-R407a-R404c)

Cod. 01.090.12

€ 98,00

> Gruppo manometrico a 4 vie con 3 tubi 150mm (rosso, giallo, blu) e valigia di trasporto, scala R134a e HFO1234yf  
> 4-way manifold with 3 hoses 150mm (red, yellow, blue) and transport case, scale for R134a and HFO1234yf  
> Colector de 4 vías con 3 mangueras de 150 mm (rojo, amarillo, azul) y caja de transporte, escaleras para R134a y HFO1234yf



Cod. 01.090.01

€ 550,00

> Pompa a vuoto bistadio 220V 50Hz con maniglia, vacuometro e elettrovalvola, portata 170lt/1', raccordi 1/4 SAE-3/8 SAE  
> Dual stage vacuum pump 220V 50Hz with handle, vacuumeter and electro-valve, capacity: 170lt/1', 1/4 SAE-3/8 SAE couplings  
> Bomba de vacío de doble etapa 220V 50Hz con mango, vacuómetro y electroválvula, capacidad: 170lt/1', acoplamientos SAE 1/4 SAE-3/8

Cod. 01.000.214

€ 260,00



> Bilancia elettronica, alimentazione batteria 9V  
Portata: 100Kg  
> Electronic scale, 9V battery power supply  
Capacity: 100Kg  
> Balanza electrónica, con alimentación batería 9V.  
Capacidad: 100Kg

Cod. 01.000.103

€ 39,50



> Coppia adattatori 1/4 SAE 5/16" SAE  
> Pair of 1/4 SAE 5/16" SAE adapters  
> Par de adaptadores 1/4 y 5/16" SAE

Cod. 01.090.10

€ 78,00



Kit Flangiatubi

Flangiatubi: Ø 6, 8, 10, 12, 16, 19 mm,  
Misura tubi: 1/4", 5/16", 3/8", 5/8", 3/4"  
Tagliatubi: 1/8"÷1.1/8" (4-28mm)

Flaring Tool Set

> Flaring: Ø 6, 8, 10, 12, 16, 19 mm,  
Tube size: 1/4", 5/16", 3/8", 5/8", 3/4"  
Tube cutter: 1/8"÷1.1/8" (4-28mm)

Juego de brida de la tubería

Ensanchador: Ø 6, 8, 10, 12, 16, 19mm  
Diámetro del tubo: 1/4", 5/16", 3/8", 5/8", 3/4"  
Cortador de tubos: 1/8"÷1.1/8" (4-28mm))

Cod. 01.090.11

€ 21,60



>Tagliatubi: 1/8"÷1.1/4" (4-32mm)  
>Tube Cutter: 1/8"÷1.1/4" (4-32mm)  
>Cortador de tubos: 1/8"÷1.1/4" (4-32mm)



**RECUPERATORI OIL-LESS MULTI-REFRIGERANTI - MULTI-REFRIGERANT OIL-LESS RECOVERERS**  
**RECUPERADORES MULTI-REFRIGERANTE SIN ACEITE**



Cod. 01.017.04

€ 1.300,00

**Oil-Less**

- > Recuperatore multigas OIL-LESS per tutti i tipi di gas refrigeranti (incluso R410A) con separatore olio esausto
- > Refrigerant Recovery Unit OIL-LESS for all types of refrigerant (included R410A) with the separator for the waste oil
- > Unidad de recuperación de refrigerante OIL-LESS para todo tipo de refrigerante (incluido R410A) con separador para aceite usado



**Corredo standard**  
**Standard equipment**  
**Equipo estándar**

**CARATTERISTICHE TECNICHE**

- a doppio pistone
- separatore olio incluso
- max pressione 38 Bar
- dimensionis: 520x220x360
- peso: 20 kg
- doppia alimentazione: 110-220V 50-60 Hz
- potenza 1 Hp
- Corredo standard: 2 tubi da 3 mt e raccordi AP/BP R134a, adattatore 1/4 SE/5/16

**TECHNICAL FEATURES**

- double piston
- oil separator included
- max pressure 38 Bar
- dimensions: 520x220x360
- weight: 20 kg
- power supply: 110-220 V 50-60 Hz
- 1 Hp power
- Standard equipment: 3 mt x 2 pcs hoses with R134a HP/LP adapters, 1/4 SAE /5/16" adapter

**CARACTERÍSTICAS TÉCNICAS**

- pistón doble
- separador de aceite incluido
- presión máxima 38 bar
- dimensiones: 520x220x360
- peso: 20 kg
- alimentación: 110-220V 50-60 Hz
- Potencia 1 Hp
- Equipo estándar: mangueras de 3 mt x 2 pcs con adaptadores AP/BP R134a, adaptador 1/4 SAE /5/16"

PRESTAZIONI RECOVERY RATE	R12-R134	R22-R407C	R404A-R407C R410A-R507
Vapore/Vapour Vapor	0.46 kg/min	0.50 kg/min	0.52 kg/min
Liquid (Recovery) Liquido (Recuperación)	3.14 kg/min	3.62 kg/min	3.70 kg/min
Push-pull Push-pull (recirculacion)	9.28 kg/min	11.14 kg/min	12.44 kg/min

**NUOVI RECUPERATORI MULTIGAS ANCHE PER HFO1234YF**

**NEW MULTI-GAS RECOVERERS ALSO FOR HFO1234YF**

**NUEVOS RECUPERADORES MULTI-GAS TAMBIEN PARA HFO1234YF**



01.017.06  
 € 1.142,00

- > Recuperatore multigas R12-R134a-R410c-HFO1234yf con motore brushless DC 3/4 HP
- Indicatore di pressione digitale, monopistone, funzione spurgo automatica
- Dimensioni 304x202x260mm
- Peso 7,8Kg

Multi-gas recovery unit R12- R134a-R410c-HFO1234yf with brushless DC motor 3/4 HP

Digital pressure gauge, single piston, automatic purge function

Dimensions 304x202x260mm

Weight 7,8kg

Unidad de recuperación multi-gas R12-R134a-R410c-HFO1234yf con motor DC sin escobillas 3/4 HP

Manómetro digital, pistón simple, función de purga automática

Dimensiones 304x202x260mm

Peso 7,8kg



01.017.05  
 € 1.275,00

- Recuperatore multigas R12-R134a-R410c-HFO1234yf
- Indicatore di pressione digitale, monopistone, compressore oil-less raffreddato ad aria, separatore olio, motore anticintilla
- Dimensioni 450x250x365
- Peso 14,7Kg

Multi-gas recovery unit for R12- R134a-R410c HFO1234yf

Digital pressure gauge, single piston, air-cooled oil-less compressor, oil separator, anti-spark engine

Dimensions 450x250x365

Weight 14,7Kg

Corredo standard

Unidad de recuperación multi-gas para R12-R134a-R410c-HFO1234yf

Manómetro digital, pistón único, compresor sin aceite refrigerado por aire, separador de aceite, motor anti-chispa

Dimensiones 450x250x365

Peso 14,7Kg

Standard kit

Kit estándar



Cod. 05.090.73

€ 23,00

**Kit smontaggio valvole impianti A/C con inserti pentalobati**  
 Utile per lo smontaggio dei tappi in plastica e della valvola interna su impianti di aria condizionata.

**Kit for disassembling valves on A/C systems with five-point bits**  
 Useful for the disassembly of the plastic caps and the internal valve of air conditioning installations.

**Kit para desmontar válvulas en los sistemas de A/A brocas de cinco lóbulos**  
 Útil para el desmontaje de las tapas de plástico y de la válvula interna de instalaciones de aire acondicionado.

**Il kit include:**

- 2 bussole femmina ottagonali
- 2 chiavi a forchetta 2,2mm/3,2mm
- 1 porta inserti 1/4"
- Kit di 7 inserti pentalobati (TS10, TS15, TS20, TS25, TS27, TS30, TS40)

**The kit includes:**

- 2 socket female octagonal wrenches
- 2 open-ended spanners 2.2mm/3.2mm
- 1 bit holder 1/4 "
- Kit of 7 five-lobed inserts (TS10, TS15, TS20, TS25, TS27, TS30, TS40)

**El kit incluye:**

- 2 llaves octogonales enchufe hembra
- 2 llaves fijas 2.2mm / 3.2mm
- 1 portapuntas de 1/4"
- Kit de 7 inserciones de cinco lóbulos (TS10, TS15, TS20, TS25, TS27, TS30, TS40)

01.000.39

€27,00



**21CR (RL 100)**

OLIO POE 100 1LT  
OIL POE 100 1LT)

01.000.122

€27,00



Olio PAG universale 1lt  
Universal PAG oil 1lt

01.000.125

€39,50



OLIO per compressori ibridi 1LT  
OIL for hybrid compressors 1LT

01.000.41

€27,96



Tracciante fluorescente U/V per impianti A/C 12 X 7.5ml con adattatore senza solventi

U/V leak detector dye for A/C systems 12 X 7.5ml with adapter - solvent free

01.000.42

€28,00



Tracciante per impianti A/C 350ml senza solventi  
Detector dye for A/C systems 350ml solvent free

01.000.124

€38,00



Tracciante fluorescente U/V per impianti A/C vetture ibride - senza solventi  
U/V leak detector dye for A/C systems for hybrid vehicles - solvent free

01.000.37

€12,00



**AV 68R**

Tanica olio per pompa a vuoto, 0,5 lt

Oil can for vacuum pump, 0,5 lt

01.000.127

€33,00



Tracciante fluorescente U/V per impianti A/C vetture ibride 12x7,5ml con adattatore - senza solventi  
U/V leak detector dye for A/C systems for hybrid vehicles 12x7,5ml with adapter - solvent free

01.000.210

€31,50



Tracciante fluorescente per impianti HFO1234YF, 12 siringhe e adattatore  
U/V leak detector dye for A/C systems with HFO1234yf, 12 syringes and adapter

**PAG 46**

01.000.177

€13,60



Olio PAG 46 per impianti HFO1234YF, 250ml minimo ordine 1 confezione da 12 pezzi  
PAG 46 oil for HFO1234YF systems, 250ml minimum order 1 package with 12 bottles

**PAG 100**

01.000.179

€14,50



Olio PAG 100 per impianti HFO1234YF, minimo ordine 1 confezione da 12 pezzi  
PAG 100 oil for HFO1234YF systems, 250ml minimum order 1 package with 12 bottles

**PAG 46**

01.000.178

€30,00

Olio PAG 46 per impianti HFO1234YF, tanichetta da 1lt.  
PAG 46 oil for HFO1234YF systems, 1Lt. bottle

**PAG 100**

01.000.180

€33,50

Olio PAG 100 per impianti HFO1234YF, tanichetta da 1 Lt.  
PAG 100 oil for HFO1234YF systems, 1 Lt. bottle

01.000.181

€33,00



>Tracciante fluorescente U/V per impianti A/C con HFO1234YF, 250ml  
>U/V leak detector dye for A/C systems with HFO1234YF, 250ml

01.000.187

Prezzo a richiesta  
Price on request  
Precio bajo pedido



>Refrigerante HFO1234yf, 5 kg (in bombole da 5 kg ricaricabili), incluso attacco rapido  
>Refrigerant HFO1234yf, 5 kg (refillable 5 kg bottles) rapid coupling included

01.000.208

€18,50

>Adattatore per bombola HFO1234yf Dupont  
>Adapter for the HFO1234yf Dupont bottle

## OSONIZZATORI PORTATILI PORTABLE OZONE GENERATORS GENERADORES DE OZONO PORTÁTILES



Esempio di calcolo tempo di sanificazione di una stanza:  
volume 3x4x3mt = 36m<sup>3</sup>  
Tempo: 36/2 = 18 minuti

Calculation example of the necessary time for a deep cleaning of a room:  
volume 3x4x3mt = 36m<sup>3</sup>  
Time: 36/2 = 18 minutes

Ejemplo de cálculo del tiempo necesario para una limpieza profunda de una habitación:  
volumen 3x4x3mt = 36m<sup>3</sup>  
Tiempo: 36/2 = 18 minutos

### COSA È L'OZONO?

L'ozono (O<sub>3</sub>) è un gas dal caratteristico odore agliaceo, le cui molecole son formate da 3 atomi di ossigeno. E' un potente agente antimicrobico che grazie alla sua azione ossidante è in grado di rendere inattivi batteri, muffe, lieviti, parassiti e virus.

### COSA PUÒ FARE L'OZONO?

L'azione deodorante e disinfettante dell'ozono dipende dalla sua forte capacità ossidante che a livello gassoso offre molti vantaggi. L'ozono purifica l'aria ed elimina totalmente gli odori sgradevoli.

### BENEFICI:

- Elimina completamente gli odori dagli ambienti e dalle superfici (autoveicoli, imbarcazioni, abitazioni, celle frigorifere, ecc.)
- Efficace contro l'odore di tabacco
- Efficace contro l'odore di cibo e animali
- Uccide rapidamente tutti i microrganismi (virus, batteri, spore, muffe, parassiti e protozoi, ecc.)
- Non necessita di manutenzione ordinaria e di nessun apporto di manodopera, di nessun prodotto o materiale di consumo
- Non utilizza sostanze dannose per l'ambiente e non lascia residui (si decompone in O<sub>2</sub>)

### APPLICAZIONI:

La bonifica degli ambienti deve essere compiuta in totale assenza di persone o animali domestici usando un ventilatore per la diffusione.

DISPONIBILI MODELLI  
PER LA BONIFICA  
DI ARIA E ACQUA  
VEDI TABELLA

### WHAT IS OZONE?

Ozone (O<sub>3</sub>) is a gas with a typical garlic-like smell whose molecules are made of 3 atoms of oxygen. It is a powerful anti-microbial that thanks to its oxidizing action it can deactivate bacteria, molds, yeasts, parasites and viruses.

### WHAT CAN OZONE DO?

The deodorizing and disinfectant action of the ozone depends on its strong oxidizing capacity which at a gaseous state offers many advantages. Ozone purifies air and eliminates any unpleasant smells.

### BENEFITS:

- It completely eliminates odors from spaces and surfaces (vehicles, boats, houses, cold storage, etc.)
- Efficient against tobacco smell
- Efficient against food and animals smell
- It rapidly kills all microorganisms (viruses, bacteria, spores, molds, parasites and protozoans, etc.)
- It does not need any ordinary maintenance or labor work, nor any product or consumables
- It does not use any substance dangerous for the environment nor it leaves any residuals (it breaks down in O<sub>2</sub>)

### APPLICATIONS:

The cleaning of the environment must be carried out in total absence of people or pets and by using a fan to spread the ozone.

MODELS FOR AIR/WATER  
TREATMENTS AVAILABLE  
(SEE TABLE)

### ¿QUÉ ES EL OZONO?

El ozono (O<sub>3</sub>) es un gas con un típico olor parecido al ajo cuyas moléculas están hechas de 3 átomos de oxígeno. Es un poderoso anti-microbiano que gracias a su acción oxidante puede desactivar bacterias, mohos, levaduras, parásitos y virus.

### ¿QUÉ PUEDE HACER EL OZONO?

La acción desodorizante y desinfectante del ozono depende de su fuerte capacidad oxidante que en un estado gaseoso ofrece muchas ventajas.

### BENEFICIOS:



- Elimina totalmente los olores de los espacios y superficies (vehículos, barcos, casas, cámaras frigoríficas, etc.)
- Eficaz contra el olor de tabaco
- Eficaz contra los olores de comida y animales
- Mata rápidamente todos los microorganismos (virus, bacterias, esporas, hongos, parásitos y protozoos, etc.)
- No necesita ningún tipo de mantenimiento ordinario o trabajo, ni ningún producto o consumible
- No utiliza ninguna sustancia peligrosa para el medio ambiente ni deja ningún residuo (se descompone en O<sub>2</sub>)

### APLICACIONES:

La limpieza del medio ambiente debe llevarse a cabo en ausencia total de personas o animales, y mediante el uso de un ventilador para esparcir el ozono.

MODELOS PARA EL TRATAMIENTO  
DE AIRE/AGUA DISPONIBLE  
(VER TABLA)



MODELLI DISPONIBILI MODELS AVAILABLE MODELOS DISPONIBLES			
	<b>Cod. 01.000.215</b>	<b>Cod. 01.000.239</b>	<b>Cod. 01.000.224</b>
Capacità Capacity Capacidad	<b>3,50 gr/h</b>	<b>3,50 gr/h</b>	<b>3,50 ÷ 7 gr/h</b> Con potenza regolabile with adjustable power con potencia ajustable
Timer Temporizador	2 ore/hours/horas	2 ore/hours/horas	2 ore/hours/horas 12 ore a richiesta/hours on request horas bajo solicitud
Rumorosità Noisiness Ruido	< 40dB	< 40dB	< 40dB
Alloggiamento Housing Alojamiento	Cabinet in acciaio verniciato Cabinet made of painted steel Alojamiento de acero pintado	Cabinet in acciaio inossidabile Stainless steel cabinet Alojamiento en acero inoxidable	Cabinet in acciaio inossidabile Stainless steel cabinet Alojamiento en acero inoxidable
Potenza_Power_Potencia	46W	40W DC/40W AC	100W
Dimensioni Dimensions Dimensiones	205x175x150 mm	205x175x150 mm	210x180x260 mm
Volume flusso aria Airflow volume Volumen del flujo de aire	2 m³/min	2 m³/min	2 ÷ 4 m³/min
Peso netto-lordo Net-gross weight Peso neto-bruto	2Kg/2,6Kg	2Kg/2,6Kg	2,9Kg/3,9Kg
Alimentazione: Power supply: Alimentación:	220/240V	12V DC / 2 20 - 240V AC	220/240V
Trattamento aria air treatment tratamiento de aire	√	√	√
	<b>€ 272,00</b>	<b>€ 307,00</b>	<b>€ 346,00</b>



Areare completamente l'ambiente bonificato prima di accedervi

Ventilate completely the area after sanitification and before entering

Ventile completamente el área después de la higienización y antes de entrar



Cod. 01.000.245

€ 520,00

# PUREZONE BIPOWER



**IN OMAGGIO**  
2 lt di prodotto igienizzante  
(per 20 vetture)

**FREE OF CHARGE**  
2 Lt of disinfecting liquid  
(for 20 vehicles)

**GRATIS**  
2 Lt de producto desinfectante  
(para 20 vehículos)

**CARATTERISTICHE TECNICHE**

- > Alimentazione duale (DC-AC)
  - > 2 timer automatici (100ml/200ml)
  - > Sensore di livello min-max
  - > Protezione per uso con temperatura >45°C
  - > Corpo in acciaio inox
  - > Dimensioni: 30x15x22,5cm
  - > Peso: 3,5kgs
- Da utilizzare con prodotti specifici (SPIN US Clean o Killer Odor)

**TECHNICAL FEATURES**

- > Dual power supply (DC-AC)
  - > 2 automatic timers (100ml/200ml)
  - > Level sensor min-max
  - > Protection against use with temperature >45°C
  - > Stainless steel body
  - > Dimensions: 30x15x22,5cm
  - > Weight: 3,5kgs
- For use with specific products (SPIN US Clean or Killer Odor)

**CARACTERÍSTICAS TÉCNICAS**

- > Fuente de alimentación doble (DC-AC)
  - > 2 temporizadores automáticos (100ml / 200ml)
  - > Sensor de nivel min-max
  - > Protección contra el uso con temperatura >45°C
  - > Cuerpo de acero inoxidable
  - > Dimensiones: 30x15x22,5cm
  - > Peso: 3,5kg
- Para uso con productos específicos (Spin US Clean o Killer Odor)

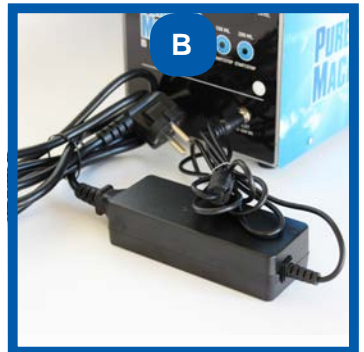

**CORREDO BASE:**

- A: Alimentatore da accendisigari 12÷24V DC
  - B: Alimentatore 100÷240V AC 50-60Hz con cavo
  - C: Convogliatore con tubo 1mt
  - D: Convogliatore diretto
- Espositore con volantini pubblicitari del servizio

**BASIC KIT:**

- A: Cigarette lighter power adapter 12 ÷ 24V DC
  - B: Power supply 100 ÷ 240V AC 50-60Hz with cable
  - C: Conveyor with hose 1mt
  - D: Direct conveyor
- Table display with flyers advertising service

**KIT BÁSICO:**

- A: Adaptador para encendedor de cigarrillos 12÷24V DC
  - B: Fuente de alimentación 100÷240V CA 50-60Hz con cable
  - C: Transportador con manguera 1mt
  - D: Transportador directo
- Stand de mesa con folletos para promover el servicio

Cod. 01.000.234

€ 1.392,00



**NEW REFRIGERANT ANALYZER  
HFO1234yf**

**NUOVO ANALIZZATORE REFRIGERANTE  
HFO1234yf**

**NUEVO ANALIZADOR REFRIGERANTE  
HFO1234yf**

**CARATTERISTICHE TECNICHE**

- Modulo di analisi "Neutronics" originale
- Pompa di lavaggio manuale per camera di misura
- Tubo 1,5mt + raccordo BP HFO1234yf con rubinetto
- Risultati secondo normativa VDA (OK - not OK) con purezza minima HFO1234yf del 95%
- Indicazione tramite LED di presenza di incondensabili (aria)
- Facile, intuitivo, economico

**TECHNICAL FEATURES**

- Original "Neutronics" analysis module
- Manual washing pump for the measuring chamber
- 1,5mt hose + BP HFO1234yf coupling with tap
- Results according to VDA regulations (OK - not OK) with a minimum HFO1234yf purity of 95%
- Indication by means of LED lights about the presence of incondensable gases (air)
- Easy, intuitive, inexpensive

**CARACTERÍSTICAS TÉCNICAS**

- Módulo de análisis "Neutronics" original
- Bomba de lavado manual para la cámara de medición
- Manguera de 1,5mt + acoplamiento BP HFO1234yf con grifo
- Resultados según las regulaciones VDA (OK - no OK) con una pureza mínima de HFO1234yf del 95%
- Indicación mediante LED acerca de la presencia de gases no condensables (aire)
- Fácil, intuitivo, económico

01.000.241

€ 39,00



**EXTREME ULTRA**

>Blister con 1 cartuccia + adattatori BP riusabile  
>Blister with 1 cartridge + BP adapters

**TURAFALLE INNOVATIVO**

PER SISTEMI A/C AUTOVEICOLI R134A / HFO123YF

**CHE COS'È?**

Prodotto indispensabile per risolvere tutti i problemi inerenti alle piccole perdite di gas refrigerante che avvengono nei circuiti frigoriferi o negli impianti di condizionamento.

**COME LAVORA?**

EXTREME localizza la perdita di gas refrigerante e la sigilla in modo permanente, senza reagire con l'umidità e l'ossigeno. EXTREME ripara perdite della dimensione massima di 0.5mm.

**INNOVATIVE LEAK STOP**

FOR CAR A/C SYSTEMS (R134A / HFO123YF)

**WHAT'S IT?**

Essential product for solving common problems related to small leakages of refrigerant gas frequently occurred from metal and rubber parts of Air Conditioning and Refrigeration Systems.

**HOW DOES IT WORK?**

EXTREME localizes the point of leak of Refrigerant and seals it permanently, without any reaction with humidity and oxygen. EXTREME stops the leakages with maximum dimensions of 0.5mm.

01.000.242

€ 44,00



**COOL-SHOT**

>Blister con 1 cartuccia + adattatori BP riusabile  
>Blister with 1 cartridge + reusable BP adapter

**VITAMINA**

per sistemi A/C autoveicoli

**Che cos'è?**

E' un catalizzatore sintetico in grado di migliorare l'efficienza dei sistemi di refrigerazione e di condizionamento, riducendo il consumo di energia.

I residui d'olio attaccati alle pareti delle tubazioni ostacolano lo scambio di calore

Oil residues, attached to the walls of tubing, block the heat exchange

Cool-Shot® elimina il fenomeno "Oil-Fouling" dalle Linee Frigorifere, consentendo al Gas Refrigerante di scorrere a diretto contatto con le superfici dei Tubi senza la barriera isolante creata dall'olio.

COOL SHOT eliminates the "Oil Fouling" from refrigeration lines, allows the refrigerant to get in direct contact with tubes surfaces without insulating barrier of the oil.

**Dopo**



**A/C Performance ENHANCER**

**What is it?**

It is synthetic catalysts making Air Conditioning and Refrigeration systems work more efficiently, thus reducing energy consumption.

**Prima**

"Oil Fouling"

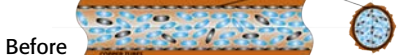

**Before**

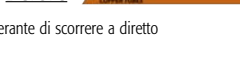

**After**

**After**



NITRO "BASIC"3000

Cod. 03.001.06

€ 1.400,00

GENERATORI DI AZOTO PER GONFIAGGIO PNEUMATICI DI AUTO E VEICOLI COMMERCIALI (SISTEMA PSA)

NITROGEN GENERATORS FOR CAR AND COMMERCIAL VEHICLE TYRE INFLATING (PSA SYSTEM)

GENÉRATEUR D'AZOTE POUR LE GONFLAGE DE PNEUS DE VOITURES ET FOURGONS (SYSTEME PSA)

GENERADORES DE NITRÓGENO PARA INFLAR NEUMÁTICOS DE COCHES Y VEHÍCULOS COMERCIALES (SISTEMA PSA)



Pressione max. aria ingresso Max. inlet air pressure Pression Max. air en entrée Presión max. de aire en entrada	Pressione azoto in uscita Outlet nitrogen pressure Pression azote en sortie Presión de nitrógeno en salida	Capacità Capacity Capacité Capacidad	Purezza minima Min. purity Pureté minimum Pureza mínima	Capacità serbatoio Tank capacity Capacité réservoir Capacidad del tanque	Alimentazione Power supply Alimentation Alimentación
10 bar (145 psi)	6-8 bar ( 85 ÷ 116 psi)	50 lt/11	96%	50lt	220V 50/60Hz

Accessori standard: Standard accessories;  
Accessoires standard: Accesorios estándar:  
2 tubi + pistola per vuoto-gonfiaggio (A)  
2 hoses + vacuum-inflating gun (A)  
2 tuyaux avec pistolet de gonflage+vide (A)  
2 tubos y generador di vacío (A)

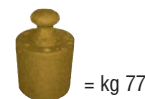
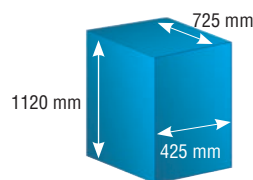

20" Full Container: \_\_\_\_ pcs

Cod. 03.000.35

€ 12,60

DISPOSITIVO SMONTAGGIO VALVOLA PNEUMATICI  
CLIP-ON CORE RETRACTING TOOL  
RETRACTOR CLIP-ON

Idoneo per portate d'aria fino a 3000lt/min.  
Utilizzabile con gonfiatori analogici o digitali  
Riduce del 50% i tempi di gonfiaggio

Suitable for an air volume up to 3000lt/min.  
It can be used with digital and analogue inflators  
It reduces by 50% the inflating time

Clip-On  
Core Retracting Tool



Apropiado para un volumen de aire de hasta 3000lt / min.  
Se puede utilizar con infladores digitales y analógicos  
Se reduce de un 50% el tiempo de inflado

Cod. 03.000.36

€ 13,60

Lock-On  
Core Retracting Tool



Come 03.000.35 con dispositivo di bloccaggio automatico  
As 03.000.35 with automatic blocking device lock-on core retracting tool.  
Como 03.000.35 con un bloqueo automático retráctil del dispositivo

Cod. 03.031.29

€ 190,00

SMONTAMOLLE PER SOSPENSIONI MULTILINK  
SPRING REMOVER FOR MULTILINK SUSPENSIONS  
REMOVEDOR DE RESORTES PARA SUSPENSIONES MULTILINK



Idoneo per fori con passaggio minimo di 30mm di diametro

Ideal for holes with a minimum diameter of 30mm

CARATTERISTICHE TECNICHE

Massimo carico: 2500kgs  
Min distanza fra flange: 70cm  
Max distanza fra flange: 167cm

TECHNICAL FEATURES

Maximum load: 2500kgs  
Min. Distance between jaws: 70cm  
Max distance between jaws: 167cm

CORREDO BASE

Mandrino di serraggio  
Coppia flange 90-120mm  
Coppia flange 120-140mm  
Barra di torsione anti sovraccarico

STANDARD EQUIPMENT

Clamping mandrel  
Pair of jaws 90.120mm  
Pair of jaws 120-140mm  
Anti-overload torsion bar

Ideal para agujeros con un diámetro mínimo de 30 mm

CARACTERÍSTICAS TÉCNICAS

Carga máxima: 2500kgs  
Min. distancia entre las mordazas: 70cm  
Max. distancia entre las mordazas: 167cm

EQUIPAMIENTO DE SERIE

Mandril de sujeción  
Par de mordazas 90-120mm  
Par de mordazas 120-140mm  
Barra de torsión anti-sobrecarga



Cod. 03.000.38

€ 398,00

**GONFIATORE ELETTRONICO PER USO INTERNO E ESTERNO**  
**ELECTRONIC TYRE INFLATOR FOR INDOOR AND OUTDOOR USE**



**INFLADOR NEUMATICOS DE ALTO FLUJO**  
**PARA USO INTERNO Y EXTERNO**

- ✓ Max. inlet pressure 10,5 Bar/152 Psi
- ✓ 8 m hose with clip-on chuck (A)
- ✓ Ideal for: Quick Service Centers, Rental Car Facilities and Car Dealers
- ✓ Max. presión de entrada 10,5 bar / 152 psi
- ✓ Manguera de 8 m con boquilla con traba (A)
- ✓ Ideal para: Centros de servicio rápido, Alquiler de coches y Distribuidores de Autobuses

- ✓ Pressione max. in entrata 10.5 bar/152 psi,
- ✓ Tubo da 8 mt + valvola di gonfiaggio (A)
- ✓ Ideale per: centri servizi rapidi, noleggio auto, concessionari



Cod. 03.000.40

€ 496,00



**GONFIATORE ELETTRONICO AD ALTO FLUSSO**  
**USO INTERNO E ESTERNO**

**HIGH FLOW TYRE INFLATOR**  
**FOR INDOOR AND OUTDOOR USE**

**INFLADOR NEUMATICOS DE ALTO FLUJO PARA**  
**USO INTERNO Y EXTERNO**

- ✓ Pressione max. in entrata 13,0 Bar/188 Psi
- ✓ Collettore a 4 uscite + 4 tubi da 2 mt con valvole di gonfiaggio di serie (B)
- ✓ Può gonfiare fino a 4 pneumatici per volta
- ✓ Ideale per: gommisti, autocarri, grandi flotte

- ✓ Max. inlet pressure 13,0 Bar/188 Psi
- ✓ Inflates 1 to 4 tyres simultaneously
- ✓ 4 way manifold kit with 4x2m hoses (B)
- ✓ Ideal for Tyre Service Centers, Tyre Mounters and Fleet Operations
- ✓ Max. presión de entrada 13,0 bar /188 psi
- ✓ Infla 1-4 neumáticos simultáneamente
- ✓ Kit colector de 4 vias con mangueras de 4x2m (B)
- ✓ Ideal para centros de servicio montadores neumáticos y trabajo con las flotas



Cod. 03.000.45

€ 74,00

**Pistola di gonfiaggio digitale "high quality" Hand held**  
**electronic inflator "high quality"**  
**Pistola de inflado digital „high quality“**

- Aluminum body, gum cover
- Battery separation
- Big backlight display
- Accuracy ± 0,08 bar (± 1 psi)
- Measure range 12 bar (175 psi)
- Measure units: PSI, BAR, KPA, KGF
- Calibration certificate included (photo B)
- Estructura de aluminio, cobertura de goma
- Separación batería
- Amplia pantalla retroiluminada
- Precisión ± 0,08 bar (± 1 psi)
- Accuratezza ± 0,08 bar (± 1 psi)
- Gamma misura 12 bar (175 psi)
- Misura in PSI, BAR, KPA, KGF
- Certificato di taratura INCLUSO (Foto B)
- Gama medición 12 bar (175 psi)
- Medición en PSI, BAR, KPA, KGF
- Certificación de calibración incluido (Foto B)



Cod. 03.031.16

€ 128,00



KIT DI 2 FLANGE  
Ø 240 MM

PER ART. SS0020/2003  
Per sospensioni  
anteriori di fuoristrada, station  
wagon

KIT OF 2 FLANGES  
Ø 240 MM

FOR ART. SS0020/2003  
For front-wheel suspensions of  
all-terrain vehicles and station  
wagons

BMW 7er (E38),  
Chrysler,  
Renault,  
GM-X &C,  
Lancia (Gamma)

KIT DE 2 BRIDAS  
Ø 240 MM

PARA ART. SS0020/2003  
Para suspensiones delanteras  
de todo terreno y station  
wagon

Cod. 03.000.47

€ 13,00

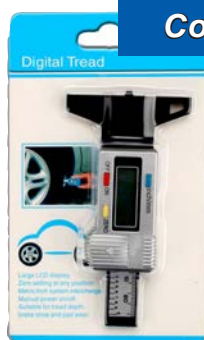

Misuratore digitale di profondità battistrada  
Digital tread depth gauge  
Medidor digital de profundidad banda de  
rodamiento

Adatto alla misurazione  
della profondità del  
battistrada  
Interscambio fra sistema  
inch/mm/inch

Suitable for measuring  
tread's depth  
Inch/mm/inch fraction  
system interchange

Adecuado para la medición de  
la profundidad de la banda de  
rodamiento  
Intercambio sistema fracción  
pulgada/mm / pulgada  
Gama:  
0-1 "/0-25.4mm/0-11/16"

Intervallo:  
0-1 "/0-25.4mm/0-11/16"

Range:  
0-1 "/0-25.4mm/0-11/16"

0-1 "/0-25.4mm/0-11/16"

Cod. 03.031.01  
SS0020/2003

€ 198,00



SMONTAMOLLE PER SOSPENSIONI MACPHERSON  
SPRING COMPRESSOR FOR  
MACPHERSON SUSPENSIONS  
EXTRACTOR DE MUELLES PARA  
SUSPENSIONES MACPHERSON

HOT!

CARRELLO PORTA GOMME DA NEVE (CON CERCHIONI)  
TIRE STORAGE RACK  
SOPORTE PARA NEUMÁTICOS CON RUEDAS

Cod. 03.031.31

€ 159,00

kit per TPMS

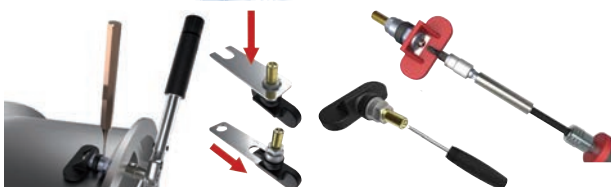

Chiave dinamometrica 2-14 N-m  
Utensile di torsione per assemblaggio  
Valvola e Sensore 0.5-3.5N-m  
Sostegno punta 150mm  
Chiave 11mm  
Chiave 12mm  
Chiave a punta T10  
Chiave a punta T15  
Chiave a punta T20  
Utensile per la rimozione valvola pneumatico  
Chiave inserimento valvola 0.25N-m  
Chiave inserimento valvola 0.4N-m

Torque wrench 2-14 N-m  
Torque Tool for Valve and  
Sensor Assembly 0.5-3.5N-m  
Bit Holder 150mm  
Socket 11mm  
Socket 12mm  
Bit Socket T10  
Bit Socket T15  
Bit Socket T20  
Tire Valve Removal Tool  
Valve Inserting Tool Torque 0.25N-m  
Valve Inserting Tool Torque 0.4N-m

Cod. 05.088.67

€ 39,90



- Capacità: 4 pneumatici da 225;
- Capacità: 125 kg;
- Struttura in acciaio verniciato
- 5 ruote, 2 con freno;
- Confezione standard: 4 carrelli
- Peso unitario: 3,5 kg;

- Capacity: 4 tires;
- Load capacity: 125kgs;
- Steel tubing with power-coated steel base for strength and durability;
- 5 wheels (2 with brake);
- Net weight of one unit: 3.5 Kgs;



- Capacidad: 4 neumáticos
- Capacidad de carga: 125kgs
- Tubos de acero con base de acero revestido para la resistencia y la durabilidad
- 5 ruedas (2 con freno)
- Peso neto una unidad: 3,5kgs

Cod. 05.090.24

€ 26,00



Supporto magnetico per avvitatore  
ad aria e bussola

2-magnets holder for air impact  
wrench and sockets

Soporte de 2 magnetos para llaves  
de impacto y brujulas



Cod. 05.091.05DP

€ 213,00

½" AVVITATORE NANO AD IMPULSI IN MATERIALE COMPOSITO A DOPPIO BATTENTE

½" MINI IMPACT WRENCH IN COMPOSITE MATERIAL WITH DOUBLE HAMMER

½" MINI LLAVE DE IMPACTO EN MATERIAL COMPUESTO CON PERCUTOR DOBLE

COPPIA DI SERRAGGIO MAX  
MAX. WORKING TORQUE  
TORSIÓN DE APRIETE MAX

1.130 Nm

Copertura anteriore

- in alluminio per uso prolungato
- **DOPPIO BATTENTE** interno

Covering

- in aluminium for a prolonged use
- **TWIN HAMMER** inside

Cobertura

- en aluminio para uso prologado
- a **PERCUTOR DOBLE** interior

Carcassa in materiale composito (solo 2 kg)

Body in composite material (2kgs only)

Cuerpo de materiales compuestos (solo 2kg)

Kit riparazione / Repair kit  
Kit de reparación

Cod. 05.091.05DPR1

€ 37,00



3 livelli di coppia selezionabili

3 levels of torque selectables

3 niveles de par seleccionables

Facile inversione di rotazione (R-F) a pulsanti

Easy rotation reversing (R-F) push- buttons

Fàcil inversiòn de rotaciòn (R-F) por botòne

Impugnatura ergonomica

Ergonomic handle

Empuñadura ergonòmica

6,2 bar  
max

TWIN HAMMER

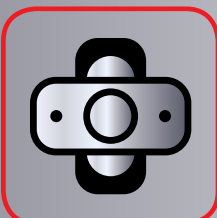

181 MM



2 KG



7500 RPM



1.130 Nm



R-F PATENT



Cod. 05.091.04DP

€ 174,00

½" AVVITATORE NANO AD IMPULSI IN MATERIALE COMPOSITO A DOPPIO BATTENTE

½" MINI IMPACT WRENCH IN COMPOSITE MATERIAL WITH DOUBLE HAMMER

½" MINI LLAVE DE IMPACTO EN MATERIAL COMPUESTO CON PERCUTOR DOBLE

COPPIA DI SERRAGGIO MAX  
MAX. WORKING TORQUE  
TORSIÓN DE APRIETE MAX

1.017 Nm

Carcassa in materiale composito (solo 1,2 kg)  
Body in composite material (1,2kgs only)  
Cuerpo de materiales compuestos (solo 1,2kg)

Copertura anteriore

- in alluminio per uso prolungato
- **DOPPIO BATTENTE** interno

Covering

- in aluminium for a prolonged use
- **TWIN HAMMER** inside

Cobertura

- en aluminio para uso prologado
- a **PERCUTOR DOBLE** interno

3 livelli di coppia selezionabili

- 3 levels of torque selectable
- 3 niveles de par seleccionables

Impugnatura ergonomica

- Ergonomic handle
- Empuñadura ergonòmica

Facile inversione di rotazione (R-F) a pulsanti

- Easy rotation reversing (R-F) push- buttons

- Fàcil inversiòn de rotaciòn (R-F) por botònes

Kit riparazione / Repair kit  
Kit de reparaciòn

Cod. 05.091.04DPR1

€ 23,50



6,2 bar max

TWIN HAMMER

116 MM

1,2 KG

7000 RPM

1.017 NM

R-F PATENT

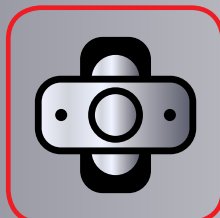



Cod. 05.091.03DP

€ 160,00

½" AVVITATORE NANO AD IMPULSI IN MATERIALE COMPOSITO A DOPPIO BATTENTE

½" MINI IMPACT WRENCH IN COMPOSITE MATERIAL WITH DOUBLE HAMMER

½" MINI LLAVE DE IMPACTO EN MATERIAL COMPUESTO CON PERCUTOR DOBLE

COPPIA DI SERRAGGIO MAX  
MAX. WORKING TORQUE  
TORSIÓN DE APRIETE MAX

746 Nm

Carcassa in materiale composito (solo 1,2 kg)  
Body in composite material (1,2kgs only)  
Cuerpo de materiales compuestos (solo 1,2kg)

Copertura anteriore

- in alluminio per uso prolungato
- **MONOBATTENTE** interno

Covering

- in aluminium for a prolonged use
- **JUMBO HAMMER** inside

Cobertura

- en aluminio para uso prologado
- a **MONOPERCUTOR** interno

Facile inversione di rotazione (R-F) a pulsanti

Easy rotation reversing (R-F) push- buttons

Fácil inversión de rotación (R-F) por botones

3 livelli di coppia selezionabili

3 levels of torque selectables  
3 niveles de par seleccionables

Impugnatura ergonomica

Ergonomic handle  
Empuñadura ergonòmica

6,2 bar max

Kit riparazione / Repair kit  
Kit de reparación

Cod. 05.091.03DPR1

€ 23,50



JUMBO HAMMER

112 MM

1,2 KG

9500 RPM

746 Nm

R-F PATENT

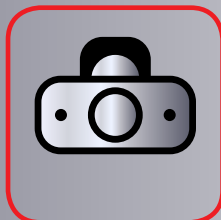



ACCESSORI PER AVVITATORI A IMPATTO  
ACCESSORIES FOR IMPACT WRENCHES  
ACCESORIOS PARA LLAVES DE IMPACTO

Cod. 05.090.88

€ 10,<sup>30</sup>

NEW!  
2018



**Bussola per smontaggio bullone antifurto, con profilo Toyota / Hyundai / Kia**  
Socket for removing anti-theft bolt with Toyota / Hyundai / Kia profile  
*Junta de extracción perno antirrobo con contorno Toyota / Hyundai / Kia*

Cod. 05.090.66

€ 9,<sup>00</sup>

MERCEDES



**Bussola per smontaggio bullone antifurto, con profilo Mercedes**  
Socket for removing anti-theft bolt with Mercedes profile  
*Junta de extracción perno antirrobo con contorno Mercedes*  
**Idonea per i modelli:**  
Suitable for the models:  
*Compatible con los modelos:*

C&GLK	W204
E	W211, W212, W207
SLK	W172
CL	W216
S	W221, W222

Ø17 L = 80mm

Cod. 05.090.24

€ 26,<sup>00</sup>



**Supporto magnetico per avvitatore ad aria e bussole**  
2-magnets holder for air impact wrench and sockets  
*Soporte de 2 magnetos para llaves de impacto y brujulas*

Cod. 05.090.58

€ 48,<sup>00</sup>



**5pcs 1/2" Drive Impact Socket Set**  
The 6pt sockets are externally sleeved to prevent damage to alloy wheels.  
Color coding for ease of size selection.  
Size: 15, 17, 19, 21, 22mm

**Bussole smontaggio bulloni 1/2", 5pz**  
Le bussole da 6pt sono dotate di manica per prevenire danni ai cerchi in lega.  
I colori permettono un facile riconoscimento delle misure.  
Misure: 15, 17, 19, 21, 22mm

**Juego de 5pcs de dados de impacto 1/2"**  
Los dados de 6pt tienen una manga externa para evitar daños en las llantas de aleación.  
Codificación de colores para facilitar la selección de las dimensiones:  
15, 17, 19, 21, 22mm

Cod. 05.090.61

€ 54,<sup>00</sup>

CR-MO



**Set bussole 1/2" 10 pz EXTRA CORTE per chiave a impulso 10-24mm**  
Prolunga 150mm  
Giunto girevole

1/2" 10pcs kit of impact sockets EXTRA SHORT for impact wrench 10-24mm  
Extension bar 150mm  
Universal joint

*Juego de 10pcs de dados 1/2" de impacto para llave de impacto 10-24mm*  
Barra de extensión de 150mm  
Junta universal

Cod. 05.090.54

€ 44,<sup>00</sup>

CR-MO



12.5 1/2"   
**Kit 9pz 1/2" inserti bussole**  
9pcs 1/2" Drive Impact Bits Socket  
*Juego de 9pcs 1/2" insertos dados*

Taglie/ Sizes/ Tallas:  
4, 5, 6, 8, 9, 10, 12, 14, 16 mm

Cod. 05.090.55

€ 44,<sup>00</sup>

CR-MO



12.5 1/2"   
**Kit 9pz 1/2" inserti bussole**  
9pcs 1/2" Drive Impact Bits Socket  
*Juego de 9pcs 1/2" insertos dados*

Taglie/ Sizes/ Tallas:  
5, 6, 7, 8, 9, 10, 12, 13, 14 mm

Cod. 05.090.56

€ 44,<sup>00</sup>

CR-MO



12.5 1/2"   
**Kit 9pz 1/2" inserti bussole**  
9pcs 1/2" Impact Sockets Set  
*Juego de 9pcs 1/2" insertos dados*

Taglie/ Sizes/ Tallas:  
T20, T25, T30, T40, T45, T50, T55, T60, T70

Cod. 05.090.57

€ 44,<sup>00</sup>

CR-MO



12.5 1/2"   
**Kit 8pz 1/2" inserti bussole esagonali**  
8pcs 1/2" Drive Impact Hex Bits Socket  
*Juego de 8 pcs 1/2" insertos dados hexagonales*

Taglie/ Sizes/ Tallas:  
5, 6, 8, 10, 12, 14, 17, 19mm

SET BUSSOLE RIMOZIONE DADI ANTIFURTO  
 SET OF SOCKETS FOR REMOVING ANTI-THEFT BOLTS  
 JUNTAS DE EXTRACCIÓN PERNOS ANTIRROBO



**ATTENZIONE! NON UTILIZZARE AVVIATORI A PERCUSSIONE con questi kit bussole rimozione dadi antifurto!**



**WARNING! DO NOT USE IMPACT WRENCH for these sets of sockets for removing anti-theft bolts!**



**ATENCIÓN! NO SE PUEDEN UTILIZAR LLAVES DE IMPACTO a percusión con estos juntas de extracción pernos antirrobo!**

Cod. 05.090.67

€ 154,00



BMW

Set 20 chiavi a bussola per rimozione dadi antifurto BMW

20 pcs anti theft wheel nut remover for BMW

20 llaves de vaso para tornillos antirrobo de ruedas BMW

OEM 36-2-010

Cod. 05.090.68

€ 96,00



PORSCHE

Set 20 chiavi a bussola per rimozione dadi antifurto PORSCHE

20 pcs anti theft wheel nut remover for PORSCHE

20 llaves de vaso para tornillos antirrobo de ruedas PORSCHE

OEM T10190

Cod. 05.090.78

€ 99,00



VW

Set 23 chiavi a bussola per rimozione dadi antifurto VW

23 pcs anti theft wheel nut remover for VW

23 llaves de vaso para tornillos antirrobo de ruedas VW

OEM T-101-01 / T40004

Cod. 05.090.77

€ 92,00



BMW

Set 21 chiavi a bussola per rimozione dadi antifurto BMW

21 pcs anti theft wheel nut remover for BMW

21 llaves de vaso para tornillos antirrobo de ruedas BMW

OEM 36-1-335

Cod. 05.090.80

€ 176,00



AUDI

Set 20 chiavi a bussola per rimozione dadi antifurto AUDI

20 pcs anti theft wheel nut remover for AUDI

20 llaves de vaso para tornillos antirrobo de ruedas AUDI

OEM T40073

Cod. 05.090.79

€ 173,00



VW

Set 20 chiavi a bussola per rimozione dadi antifurto VW

20 pcs anti theft wheel nut remover for VW

20 llaves de vaso para tornillos antirrobo de ruedas VW

OEM T10133

Cod. 05.090.81

€ 226,00



MERCEDES

Set 35 chiavi a bussola per rimozione dadi antifurto MERCEDES

35 pcs anti theft wheel nut remover for MERCEDES

35 llaves de vaso para tornillos antirrobo de ruedas MERCEDES

OEM 301-332



Ø max  
650 mm

Cod. 05.084.10

€ 420,<sup>00</sup>

**Sollevatore idraulico per ruote (auto, suv, fuoristrada, furgoni) BREVETTATO**

- Diametro max pneumatico: 650mm
- Capacità: 100kgs max
- Altezza min.: 1010mm
- Altezza max.: 1910mm
- Peso netto/lordo: 62/66kgs
- Dimensioni imballo: 1155x708x200mm

**Hydraulic lift for wheels (car, suv, off-road vehicles, vans) PATENTED**

- Max tyre diameter: 650mm
- Capacity: 100kgs
- Min. height: 1010mm
- Max. height: 1910mm
- Net/gross weight: 62/66kgs
- Package dimensions: 1155x708x200mm

**Elevador hidráulico para ruedas (coche, suv, vehículos todoterreno, furgonetas) PATENTADO**

- Max diámetro neumático: 650mm
- Capacidad: 100kgs
- Altura min.: 1010 mm
- Altura max.: 1910mm
- Peso neto/bruto: 62/66kgs
- Dimensiones del embalaje: 1155x708x200mm



Ø max  
1000 mm

Cod. 05.084.18

€ 515,<sup>00</sup>

**Attrezzatura per montaggio, smontaggio e spostamento di ruote veicoli commerciali e veicoli industriali**

- Diametro max pneumatico: 1000mm
- Capacità: 1000kgs
- Dimensioni macchina montata: 1040X1090X890mm
- Peso netto/lordo: 68/75kgs
- Dimensioni imballo: 1160X900X160mm

**Equipment for assembly, dismantling and movement of commercial and industrial vehicles**

- Max tyre diameter: 1000mm
- Capacity: 1000kgs
- Assembled machine size: 1040X1090X890mm
- Net/gross weight: 68/75kgs
- Package dimensions: 1160X900X160mm

**Equipo para el montaje, el desmontaje y el desplazamiento de los vehículos comerciales y los vehículos industriales**

- Max diámetro neumático: 1000mm
- Capacidad: 1000kgs
- Tamaño máquina montada: 1040X1090X890mm
- Peso neto/bruto: 68/75kgs
- Dimensiones del embalaje: 1160X900X160mm



Ø max  
1800 mm

Cod. 05.084.11

€ 870,<sup>00</sup>

**Sollevatore idraulico per ruote di veicoli commerciali, industriali, macchine agricole**

- Diametro max pneumatico: 1800mm
- Altezza di sollevamento: 0-770mm
- Capacità: 1200kgs
- Dimensioni macchina montata: 1270x990x1340mm
- Peso netto/lordo: 106/121kgs
- Dimensioni imballo: 1398x448x368mm
- Smontabile

**Hydraulic lift for wheels of commercial, industrial vehicles and agricultural machinery**

- Max tyre diameter: 1800mm
- Lifting height: 0-770mm
- Capacity: 1200kgs
- Assembled machine size: 1270x990x1340mm
- Net/gross weight: 106/121kgs
- Package dimensions: 1398x448x368mm
- Dismountable

**Gato hidráulico para ruedas de vehículos comerciales, industriales y máquinas agrícolas**

- Max diámetro neumático: 1800mm
- Altura de elevación: 0-770mm
- Capacidad: 1200kgs
- Tamaño máquina montada: 1270x990x1340mm
- Peso neto/bruto: 106/121kgs
- Dimensiones del embalaje: 1398x448x368mm
- Desmont



> Spurgofreni elettrico carrellato  
> *Portable electrical brake bleeder*

Cod. 03.036.22

€ 792,00



> Spurgofreni elettrico carrellato.  
Idoneo per taniche fino a 12 litri.  
• Pressione regolabile 0 ÷ 6 bar  
• Lunghezza tubo 3500 mm  
• Alimentazione 220/230 Volt

> Portable electrical brake bleeder.  
Suitable for max 12 liters tank  
• Adjustable pressure 0 ÷ 6 bar  
• Hose length 3500 mm  
• Power supply 220/230 Volt

CORREDO STANDARD / STANDARD EQUIPMENT



> Kit adattatori universali  
> *Universal adapters*



Kit A

Cod. 03.036.23 € 128,00



Kit B

Cod. 03.036.24 € 198,00

optional / a richiesta

KIT TAPPI PER SPURGOFRENI  
MASTER CYLINDER ADAPTER KIT  
JUEGO DE TAPONES PARA SANGRADORES DE FRENOS

Cod. 03.036.28

€ 202,00

- adatto per la maggior parte degli spurgafreni a pressione
- adattatore per tappi europei, tappi multiveicolo, tappo americano (GM), BMW/Audi, Nissan, Mazda e Honda
- adattatori universali e tappi di produttori specifici
- gli adattatori son compatibili col 90% dei serbatoi attuali del cilindro maestro

- suitable for most pressure brake bleeders
- European cap adapter, multi vehicle caps, American adapter (gm), BMW/Audi, Nissan, Mazda & Honda
- universal adapters and manufacturer specific caps
- adapters fit 90% of current master cylinder reservoirs

- adecuado para la mayoría de los sangradores de freno de presión
- Adaptador para tapon europeo, tapones multi-vehículo, tapon americano (GM), BMW/Audi, Nissan, Mazda y Honda
- adaptadores universales y tapones especificos del fabricante
- los adaptadores caben el 90% de los depósitos actuales de los cilindros maestros

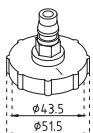
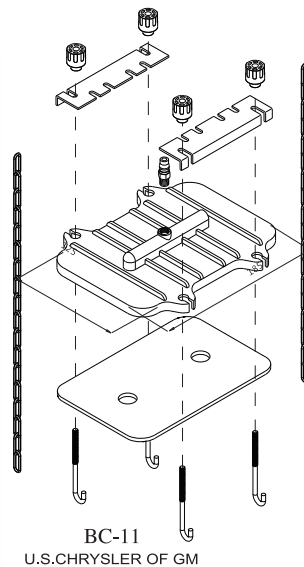

BC-01

CHRYSLER, DODGE, JEEP, PLYMOUTH

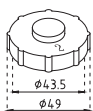

BC-02

CHRYSLER, DODGE, JEEP, PLYMOUTH

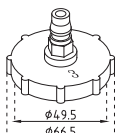

BC-03

MOST LATE MODEL GM CARS/BUICK, CADILLAC, CHEVROLET, GMC, HUMMER, OLDSMOBILE, PONTIAC/SOME MAZDA

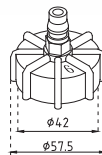

BC-06

MOST EUROPEAN CARS (ALFA ROMEO, AUDI, BMW, JAGUAR, LAND ROVER, MERCEDES, PEUGEOT, PORSCHE, RENAULT, SAAB, VW, VOLVO), CHRYSLER CROSSFIRE, DAEWOO, LATE MODEL FORD, KIA, SOME MAZDA, AND MINI

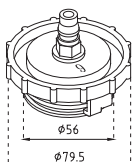
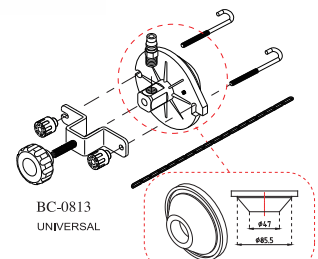

BC-09

HONDA ACCORD CARS

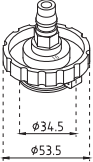

BC-10

NISSAN CARS

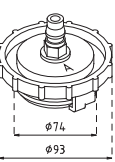

BC-12

HONDA

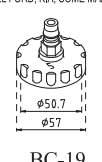

BC-19

ALL HYUNDAI, MITSUBISHI, NISSAN, AND SUBARU, SOME CHRYSLER/DODGE, SOME FORD/LINCOLN



BC-21

TOYOTA & LEXUS

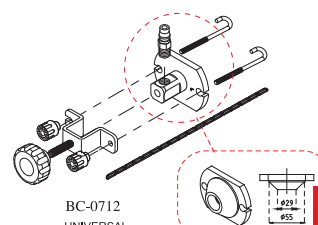



**HOT!**

Cod. 05.058.01

€ 118,<sup>00</sup>

**NUOVO KIT REGISTRO PISTONCINI FRENI CON PISTONE PNEUMATICO**  
**NEW BRAKE CALIPER TOOL KIT WITH PNEUMATIC PISTON**

**NUEVO CALIBRADOR NEUMÁTICO DE FRENOS CON PISTÓN NEUMÁTICO**

Il pistone pneumatico mantiene la pressione sul cilindretto che può essere facilmente ruotato verso destra o verso sinistra dalla leva.

The pneumatic piston maintains the pressure on the cylinder that can be easily turned right or left by using a lever.

El pistón neumático presiona el cilindro que se puede girar a la derecha o a la izquierda utilizando la palanca.

Cod. 05.058.07

€ 38,<sup>50</sup>



**AGGIORNAMENTO AL KIT**  
**UPGRADE FOR KIT**  
**ACTUALIZACIÓN PARA KIT**  
**05.058.01**

**HOT!**

APPLICAZIONI / APPLICATIONS / APLICACIONES

B1 Ford      B4 BMW      W Passat VW  
B3 BMW      B5 Mini/BMW      B2 Iveco Daily

Cod. 05.058.09

€ 40,<sup>00</sup>

**Set 3pcs arretratori pistoncini**

**Kit of 3 pcs of small pistons' pullers**

**Kit de 3 piezas de extractores para pistones pequeños**



Aggiornamento al kit - Upgrade for kit - Actualización para kit  
**05.058.01**

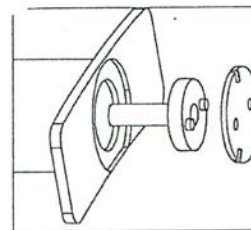

**Il kit include/the kit includes/el kit incluye:**

- A) VW, Audi A4-5-6-8, VW Passat, Tiguan 2007
- B) BMW, Mini, Smart, VW
- C) Nissan - Opel - Toyota

Cod. 05.058.08

€ 12,<sup>80</sup>



**Kit rimozione pinze freno 3pcs**

**Brake calipers' dismantling kit 3pcs**

**Kit de desmontaje pinzas de freno 3 un.**

**Il kit include:**

**CHIAVE PENTAGONALE DA 14MM** per Opel Zafira, Astra, Smart

**CHIAVE PENTAGONALE DA 19 MM** per pinze Bendix (Citroen, Peugeot, Renault)

**CHIAVE PENTAGONALE DA 10MM** per pinze Girling

**The kit includes:**

**14MM PENTAGONAL socket wrench** for Opel Zafira, Astra, Smart

**19MM PENTAGONAL SOCKET wrench** for Bendix calipers (Citroen, Peugeot, Renault)

**10 MM MALE PENTAGONAL socket wrench** for Girling calipers

**El kit incluye:**

**LLAVE PENTAGONAL DE 14MM** para Opel Zafira, Astra, Smart

**LLAVE PENTAGONAL DE 19MM** para pinzas Bendix (Citroen, Peugeot, Renault)

**LLAVE PENTAGONAL DE 10MM** para pinzas Girling

Cod. 05.088.60

€ 92,<sup>00</sup>



**PORTA PNEUMATICI DA PARETE**  
**WALL TIRE HOLDER**  
**SOPORTE NEUMATICOS DE PARED**

Dimensions: 72x74x167cm  
Weight: 15kgs (assembled)

Dimensiones: 72x74x167cm  
Peso: 15kgs (montado)

Dimensioni: 72x74x167cm  
Peso: 15kgs (montato)



05.056.00	05.056.01	05.056.07	<b>SET DI CHIAVI SMONTAGGIO FILTRI OLIO PER AUTO E FURGONI OIL FILTERS CUPS KITS FOR CARS-VANS SET DE LLAVES PARA FILTROS ACEITE COCHES-CAMIONETAS</b>	
■	■	■	66mm/6P	Fiat Punto, 1 2) Renault (Clio 1 2 Express, Kangoo Twingo) etc
■	■	■	65mm/14P	Fits Champ. Hastings GnVAc. wix, Napa, Purolator, Diahatsu, Toyota Nissan etc
■	■	■	65-67mm/14P	Fits same filters as made in Canada including PH4386 PH4967 PH6017 PH6018 Daihatsu etc
■	■	■	68mm/14P	Fits Hastings. Mazda, Ford Escor, Capri, Subaru, Fran PH6607 (those tram filters made in Korea), Motorcraft FLS16 etc)
■	■	■	73mm/14P	Fits Toyota/Lexus, etc
■	■	■	74mm/15P	MF. Audi, #056-115-561g, GM. Rover. Chrysler, etc..
■	■	■	74-76mm/15P	Fits Fram, Ac. Saturn. etc
■	■	■	75-77mm/15P	Fits VW. Audi Casite. GM/AC. Hastings Wix. NAPA Ford Isuzu Mercedes, opel, etc.
■	■	■	76mm/12P	Fiat (Ducato. Scudo. Ulysee), Renault. (Megane Laguna Espace III) etc
■	■	■	76mm/14P	Fist Champion. Champ Lee, Purolator, Mopar. VW, Porsche, Mercedes Benz, BMW, Audi. (I. B. A3TD) Opel etc
■	■	■	76mm/30P	Fits Motorcraft only-FL400A. Ford etc
■	■	■	76mm/8P	Fiat(Marea), Lancia (Delta) etc.
■	■	■	78mm/15P	Nissan #15208H8991. Ford, Toyota, Accord etc
■	■	■	80mm/15P	Fits Hastings Fram, Purolator, Nissan. Honda. Motorcraft. Mazda, Isuzu, Subaru. Opel. Toyota, etc
■	■	■	80-82mm/15P	Fits Wix filters branded for Mazda, Subaru, Toyota, Honda. Acura Nissan, NAPA etc.
■	■	■	86mm/16P	Volvo(S40.S60.S70.S80) etc
■	■	■	86mm/18P	VW Golf(MKIII Tdi, passat Tdi.) Audi A6 Tdi, Renault (Clio Rapid 1 9D Laguna Safrane Espace 21D) Citroen. Peugeot, Renault, etc
■	■	■	90mm/15P	Fits Honda Accord Mitsubishi Mopar Isuzu etc
■	■	■	92mm/10P	Fiat Cinquecento, Coupe, Croma. Fiat. Panda Regata Ritmo Fiat. Seicento Tempra. Tipo. Lancia (Beta Dedra Kappa Monte Carlo Prisma Thema Trevi)etc
■	■	■	93mm/15P	Fits Casite, Champ. Champion, GM. Fram. Hastings Opel, Mazda, Volvo, Mitsubishi Purolator. Wix, Nissan, VW, Porsche. Renault Ford, Honda, Audi. etc
■	■	■	93mm/36P	Fits Motorcraft only-FL1A, FLA1B. FL300. FL820. Ford, etc
■	■	■	93mm/45P	VW-Audi (Tdi2 4.2 6,2 8L)etc
■	■	■	95mm/15P	Toyota #15600-41010 Alfa. GM, Ford. ALFA, Chrysler, etc
■	■	■	96mm/18P	Audi(A4 A6 Tdi). VW(Passaf 97 Tdi) Renault (Laguna 2.2d Safrane 2.2D.) Espace 2.2D R19. RAPID. MEGANE. 1 9/2 1D TDi)etc
■	■	■	100mm/15P	Fits fram, Motorcraft. wix, Isuzu and Mitsubishi, etc
■	■	■	106mm/15P	Fiat(Ducato 2 5D Td)etc
■	■	■	108mm/15P	Volvo(C70.S70.V70.Tdi TD)(Turbo. Diesel 850 Tdi Diesel)etc
■	■	■	108mm/18P	Renault (Espace, Laguna. Master, Safrane, Traffic 2.4, 2.5, 2.8D, TD) etc
■	■	■	A2089	
■	■	■	Adaptor	

Cod. 05.056.00 € 46,00



Cod. 05.056.01 € 56,00



Cod. 05.056.07 € 88,00



HOT!

Cod. 05.056.03 € 27,00



Per - For - Para Mercedes, Smart, VW, Opel, BMW (24/27/32/36/38mm)



Cod. 05.056.08 € 14,00

**CHIAVE SMONTAGGIO FILTRO GASOLIO (motori Hdi)  
FUEL FILTER SOCKET (HDi engines)  
LLAVE PARA FILTRO DE COMBUSTIBLE (MOTORES HDI)**

- Chiave smontaggio filtro gasolio speciale per motori Hdi
- Specialist socket required for the removal of diesel fuel filter fit for HDi engines
- Llave para especialistas requerida para la remoción del filtro de combustible diesel para motores HDI

**Modelli / Models / Modelos:**

C4 2.0 HDi 16v, C4 Picasso 2.0/2.2 HDi, C5, C8 2.0/2.2 HDi 16v, Jumpy 2.0/ 2.2 HDi;  
Fiat Scudo, Ulysse Mk II 2.0 JTD 16v;  
Ford Focus/ Focus C-Max Galaxy/ Kuga S-Max 2.0 TDCi;  
Peugeot 307/ 308/ 407/ 607 807/ Expert 2.0 HDi 16v;  
Volvo C30/ C70/ S40 Mk II, V50 2.0 Diesel (136 HP).





**SET 6 CHIAVI PER FILTRI OLIO (COLORATE)**  
**KIT OF 6 WRENCHES FOR OIL FILTERS (COLOURED)**  
**JUEGO DE 6 LLAVES PARA FILTROS ACEITE (COLORADAS)**

Cod. 05.056.09

€ 118,00



Foto/Picture/Imagen

IL KIT INCLUDE: THE KIT INCLUDES: EL KIT INCLUYE:

	COLORE COLOUR COLOR	APPLICAZIONI USES USOS	Ømm/lati sides lados
A	Rosso - Red - Rojo	Mercedes Benz Jeep - Chrysler	Ø84 - 14
B	Verde - Green - Verde	BMW - Volvo	Ø86 - 16
C	Blu - Blue - Azul	Kia Hyundai	Ø89 - 15
D	Giallo - Yellow - Amarillo	Alfa Romeo - Fiat Opel - Suzuki	Ø75 - 16
E	Azzurro - Light Blue Azul claro	Hyundai	Ø77 - 15
F	Celeste - Pale blue Azul palido	Alfa Romeo, Fiat, Lancia	Ø90 - 10

Cod. 05.056.16

€ 44,00

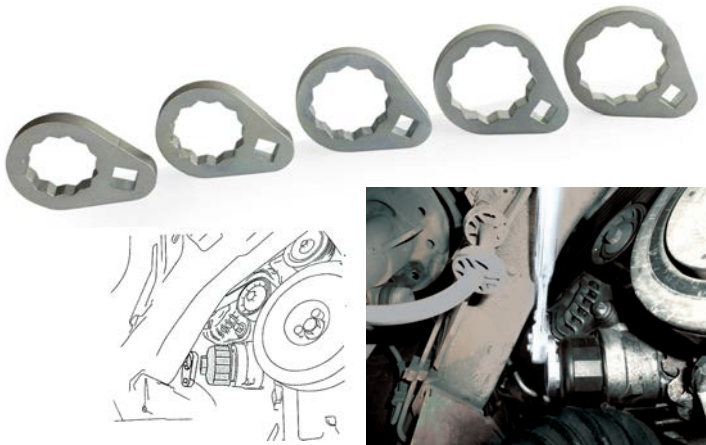

**Set 5 chiavi esagonali per smontaggio filtri olio  
in zone di difficile accesso - Ø3/8"**

**Set of 5 hexagonal wrenches for oil filters removal  
in difficult-to-access areas - Ø3/8"**

**Juego de 5 llaves hexagonales para la extracción de  
filtros de aceite en zonas de acceso difícil - Ø3/8"**

Misure: Measures: Medidas: 24/27/32/36/38mm

Cod. 05.062.05

€ 17,00



**Pinza per filtri olio Ø46mm (VW, Audi, Skoda, Seat)**

**Pliers for oil filters Ø46mm (VW, Audi, Skoda, Seat)**

**Alicates para filtros de aceite Ø46mm (VW, Audi, Skoda, Seat)**

Cod. 05.056.13

€ 44,00



**COPPIA CUNEI PER  
SMONTAGGIO FILTRI  
GASOLIO E FILTRI  
LUNGO IL CONDOTTO  
CARBURANTE  
(VETTURE VAG, FIAT, JEEP,  
CHRYSLER)**

**PAIR OF WEDGES  
FOR DIESEL FILTERS  
REMOVAL  
AND FILTERS ALONG  
THE FUEL LINE  
(VAG, FIAT, JEEP, CHRYSLER  
VEHICLES)**

**PAR DE CUÑAS PARA LA  
EXTRACCIÓN FILTROS  
DIESEL Y FILTROS A LO  
LARGO DE LA LÍNEA DE  
COMBUSTIBLE  
(VAG, FIAT, JEEP, CHRYSLER)**

Filtro gasolio  
Diesel filter  
Filtro diesel



Esempio di filtro gasolio montante il raccordo citato  
Example of diesel filter needing the mentioned coupling  
Ejemplo de filtro diesel que necesita el acoplamiento mencionado

NEW!  
2018



Cod. 05.090.84

€ 96,<sup>00</sup>

SET DI 6 FUSTELLE PER FORATURE PARAFANGHI  
PER MONTAGGIO SENSORI DI PARCHEGGIO  
17/18.2/19/20/21/22mm  
per VW, Audi, Skoda, Seat, BMW

HOLE CUTTING TOOL SET FOR PDC  
(PARK DISTANCE CONTROL)  
17/18.2/19/20/21/22mm  
for fenders on VW, Audi, Skoda, Seat, BMW

JUEGO DE HERRAMIENTAS DE CORTE DE AGUJEROS  
PARA CONTROL DE DISTANCIA DEL PARQUE  
17/18.2/19/20/21/22mm  
para guardabarros en VW, Audi, Skoda, Seat, BMW

NEW!  
2018



Cod. 05.090.83

€ 70,<sup>00</sup>

INSERITORE A PERCUSSIONE  
PER CUSCINETTI/PARAOLI  
da Ø 18 ÷ 90mm, regolabile

Peso: 15,3kg

PERCUSSION INSERTER  
FOR BEARINGS/OIL SEALS  
from Ø 18 ÷ 90mm, adjustable

Weight: 15,3kg

DISPOSITIVO COLOCADOR DE PERCUSIÓN  
PARA COJINETES/RETENES PARA ACEITE  
de Ø 18 ÷ 90 mm, ajustable  
Peso: 15,3kg

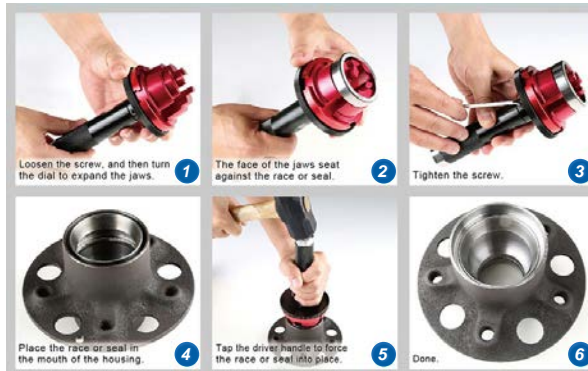

Cod. 05.062.06

€ 22,<sup>00</sup>

SET DI 3 PINZE PER MANICHETTA FLESSIBILE  
3 PCS HOSE CLIP PLIERS  
JUEGO DE TRES PINZAS  
PARA MAGUERAS FLEXIBLES  
1/2" - 5/8" - 2/4"



NEW!  
2018

Cod. 05.078.07

€ 80,<sup>00</sup>

NEW!  
2018



LEVA DI TRAZIONE UNIVERS  
WISHBONE LEVER TOOL  
EXTRACTOR BRAZO DE SUSPENSION

- Lunghezza: 120cm
- Diametro tubo: 3.5cm
- Distanza fissaggio: 50, 45, 40, 35, 30cm
- Length: 120cm
- Diameter tube: 3.5cm
- Brace distance: 50, 45, 40, 35, 30cm
- Longitud: 120cm
- Diámetro del tubo: 3.5 cm
- Distancia de fijación: 50, 45, 40, 35, 30 cm

Cod. 02.022.113

€ 286,00

NEW!  
2018

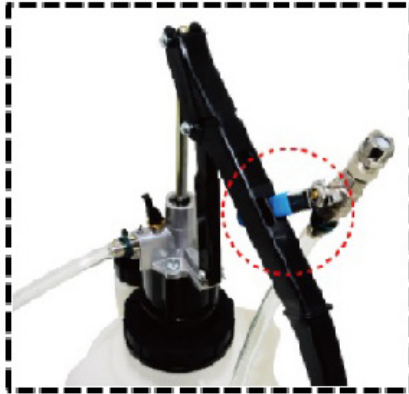

**POMPA MANUALE PER L'INSERIMENTO DI OLIO NEI CAMBI MANUALI, AUTOMATICI E NEI DIFFERENZIALI**

- Il kit include 12 adattatori per la connessione diretta
- Valvola di non ritorno per un'efficace azione di inserimento dell'olio senza perdite
- Portata: 70cc a pompata
- Capacità serbatoio: 9 lt
- Massima viscosità olio utilizzabile: SAE 140

**MANUAL PUMP FOR THE INSERTION OF OIL IN MANUAL, AUTOMATIC AND DIFFERENTIAL TRANSMISSIONS**

- The kit includes 12 adapters for direct connection
- Non-return valve for an effective oil insertion action without leaks
- Flow: 70cc per stroke
- Tank capacity: 9 lt
- Maximum viscosity of usable oil: SAE 140

**BOMBA MANUAL PARA LA INSERCIÓN DE ACEITE EN TRANSMISIONES MANUALES, AUTOMÁTICAS Y DIFERENCIALES**

- El kit incluye 12 adaptadores para conexión directa
- Válvula de retención para una acción efectiva de inserción de aceite sin fugas
- Flujo: 70cc por carrera
- Capacidad del tanque: 9 lt
- Viscosidad máxima del aceite utilizable: SAE 140

AT-101



AT-102



AT-103



AT-104



AT-105



AT-112

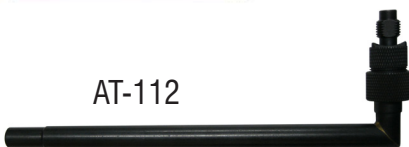

AT-106



AT-107



AT-108



AT-109



AT-110



AT-111



FORD 1/8 NPT	AT-101
UNIVERSAL (BMW, Honda, Nissan etc.)	AT-102
VW-AUDI	AT-103
VW-AUDI-PORSCHE	AT-104
VW-AUDI-MINI COOPER 10X1.0	AT-105
MERCEDES 722.9 12X1.5	AT-106
DSG 24X1.5	AT-107
VW-AUDI CVT 22X1.5	AT-108
VOLVO 5/16X24	AT-109
TOYOTA-LEXUS 18X1.5	AT-110
SKODA 30X1.5	AT-111
VW PASSAT/TIGUAN <2007	AT-112



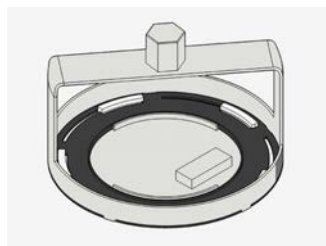

Cod. 05.056.10

€ 45,00

**Chiave a 5 denti per ghiera galleggianti FIAT**  
**Five-legged wrench for FIAT floats' ferrule**  
**Llave de cinco patas para las cabezas de los flotadores metálicos Fiat**

Chiave a 5 denti per le ghiera dei galleggianti in metallo montate sui serbatoi delle nuove vetture del gruppo FIAT (FIAT Freemont, Fiat 500L, Fiat 500X, Jeep Renegade ecc.)  
Consente di rimuovere la ghiera (fissata con sistema a baionetta) e la guarnizione sottostante senza danni. Agisce di precisione sulle tacche esterne, evitando così eventuali costose sostituzioni.

Five-legged wrench for the ferrules of metal floats' mounted on the tanks of new Fiat group cars (Fiat Freemont, Fiat 500L, Fiat 500X, Jeep Renegade etc.)  
It allows to removes the ferrule (fixed with a bayonet system) and the underlying seal without making any damage  
It works with precision on the outer notches, thus avoiding any costly replacements

Llave de cinco patas para las cabezas de los flotadores metálicos montados en los tanques de los nuevos coches grupo Fiat (Fiat Freemont, Fiat 500L, Fiat 500X, Jeep Renegade etc.)  
Permite de quitar la cabeza (fijada con un sistema de bayoneta) y la junta subyacente sin hacer ningún daño. Funciona con precisión en las entalladuras exteriores, evitando así cualquier reemplazo costoso

Cod. 05.056.11

€ 46,00



**Chiave a 3 zampe per ghiera galleggianti**  
**Three-legged wrench for floats' ferrule**  
**Llave de tres patas para cabeza de flotadores**

(Fiat, VW, Audi, Opel, Chevrolet, Mercedes Benz, BMW)

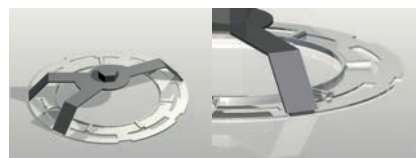

Agisce di precisione sulle tacche esterne, evitando così eventuali costose sostituzioni

It works with precision on the outer notches, thus avoiding any costly replacements

Funciona con precisión en las entalladuras exteriores, evitando así cualquier reemplazo costoso

Cod. 05.056.12

€ 54,00



**Chiave regolabile per smontaggio ghiera galleggianti**  
**Range: 89-170mm**

Utilizzabile sia all'interno che all'esterno della ghiera

**Adjustable wrench for removing floats' ferrules**  
**Range: 89-170 mm**

It can be used both inside and outside the ring

**Llave ajustable para quitar cabezas de Rango: 89-170mm**  
Se puede utilizar tanto dentro como fuera de la cabeza

Cod. 05.056.15

€ 53,00

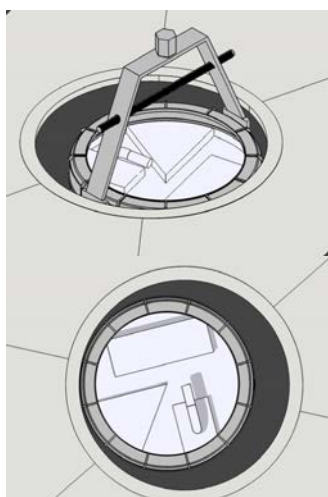

**CHIAVE GHIERE GALLEGGIANTI SERBATOI PEUGEOT-CITROEN**

**WRENCH FOR FLOATS' FERRULES ON PEUGEOT-CITROEN TANKS**

**LLAVE PARA CABEZAS DE REGLAJE FLTADORES TANQUES PEUGEOT-CITROEN**

Chiave per le ghiera dei galleggianti presenti sui serbatoi delle nuove vetture Citroen e Peugeot. L'asse decentrata e la fragilità del pescante rendono difficile la rimozione della ghiera. La chiave appositamente studiata si incastra sulla sottile dentatura consentendo una facile estrazione

Wrench for the ferrules of the floats on the tanks of new Citroen and Peugeot vehicles. The decentralized axis and the fragility of the float makes it difficult to remove the ring. The specially developed wrench fits on thin teeth allowing an easy extraction

Llave para las cabezas de los flotadores en los tanques de los nuevos vehículos Citroen y Peugeot. El eje descentralizado y la fragilidad del flotador hacen que sea difícil de quitar el anillo. La llave especialmente diseñada se encaja en los dientes finos permitiendo una extracción fácil

Cod. 05.019.03

€ 248,00



HOT!

**PROVA RADIATORI  
E RIEMPIMENTO RADIATORI SOTTOVUOTO**  
(26PZ)

**COOLING SYSTEM ANALYZER  
AND RADIATORS FILL VACUUM**  
(26PCS)

**PROBADOR DE RADIADORES  
Y LLENADOR DE RADIADORES BAJO VACÍO**  
(26UDS)

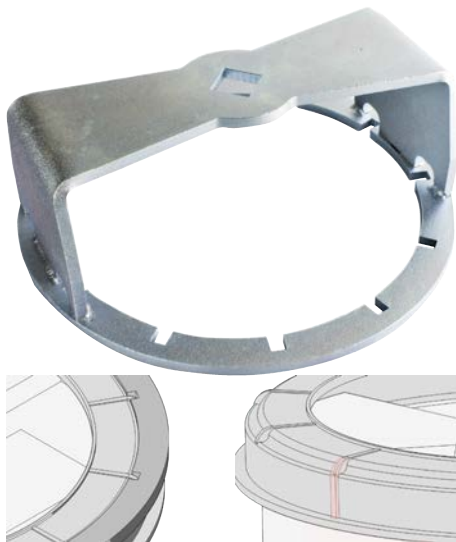
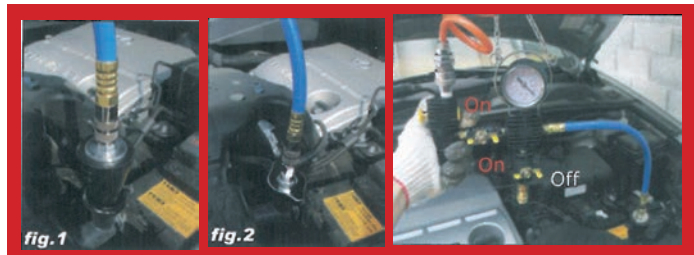

Cod. 05.056.14

€ 43,00

**CHIAVE PER GHIERE GALLEGGIANTI SERBATOI FIAT  
WRENCH FOR FLOATS' FERRULES ON FIAT TANKS  
LLAVE PARA CABEZAS DE REGLAJE FLOTADORES TANQUES FIAT**

Chiave per le ghiera dei galleggianti presenti sui serbatoi delle nuove vetture del gruppo Fiat-Alfa-Lancia (auto e furgoni) e Ford.

Consente di rimuovere anche le nuove ghiera sprovviste delle incisioni laterali. Gli intagli sulla corona permettono di lavorare in presa sui 12 denti ribassati della ghiera, agevolandone l'estrazione e prevenendo danni e conseguente sostituzione

Wrench for the ferrules of floats on the tanks of new vehicles like Fiat-Alfa-Lancia group (cars and vans) and Ford.

It allows to remove even the new ferrules that lack the lateral incisions. The slots on the crown teeth of the ferrule, facilitating the extraction and preventing damage and subsequent replacement

Llave para las cabezas de reglaje de flotadores en los tanques de los vehículos nuevos como grupo Fiat-Alfa-Lancia (coches y furgonetas) y Ford.

Permite eliminar incluso las nuevas cabezas donde no hay las incisiones laterales. Las ranuras en la corona permiten trabajar en los 12 dientes más bajos de la cabeza, facilitando la extracción y la prevención de daños y posterior sustitución

Cod. 05.090.72

€ 320,00



**Kit di 36 utensili per estrazione e introduzione  
silent blocks, paraoli e cuscinetti**

attrezzatura universale per settore auto e camion

**Kit of 36 tools for the extraction and insertion  
of silent-blocks, oil blocks and bearings**

universal equipment for the vehicles' and trucks' industry

**Kit de 36 herramientas para la extracción e inserción  
de silent-blocks, bloques aceite y cojinetes**

Equipo universal para el sector de los camiones y vehículos

Il kit contiene:

4 barre filettate  
(M10, M12, M14, M16) e  
20 bocche per: interni  
Ø (34, 36, 38, 70, 72mm)  
ed esterni  
Ø (44,46, 48, 80, 82mm)

The kit includes:

4 threaded bars  
(M10, M12, M14, M16),  
20 bushings for:  
internal Ø (34, 36, 38, 70,72mm)  
and external  
Ø (44, 46, 48, 80, 82mm)

El kit incluye:

4 barras roscadas  
(M10, M12, M14, M16),  
20 bushings para: diámetros  
internos (34, 36, 38, 70, 72 mm)  
y externos (44, 46, 48, 80, 82 mm)





Cod. 05.067.01

€ 109,00

**Utensile universale a mezzaluna bloccapuleggie per smontaggio puleggie di distribuzione**

Regolabile tramite manico girevole, blocca la puleggia dell'esterno evitando eventuali danni a sensori circostanti

**Universal crescent-shaped tool for holding pulleys in position and dismantling distribution pulley**

Adjustable via turning handle, it locks the pulley from outside avoiding damage to surrounding sensors

**Herramienta universal en forma de medialuna para sujetar poleas en posición y desmontar la polea de distribución**

Ajustable mediante mango giratorio, bloquea la polea para evitar daños a los sensores circundantes

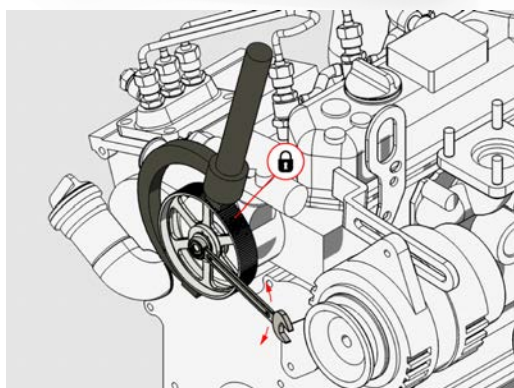

Cod. 05.090.75

€ 13,00



**Chiave smontaggio tappi olio in plastica (Gruppo VW-Audi)**

**Wrench for dismantling oil caps in plastic (VW-Audi Group)**

**Llave para desmontar las tapas de aceite en plástico (Grupo VW-Audi)**

Cod. 03.036.25

€ 27,50

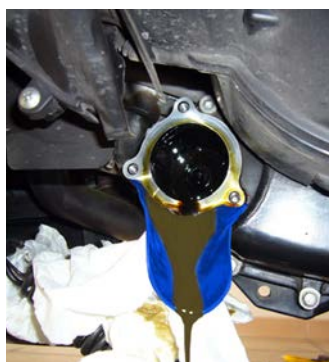

**Convogliatore olio in alluminio rivestito in gomma  
Aluminum oil conveyor coated in plastic  
Embudo transportador aceite recubierto en plástico**

Cod. 05.062.01

€ 45,00



Pinza per serraggio e taglio fascette in acciaio inox  
Pliers for tightening and cutting stainless steel clamps  
Pinza para apretar y cortar abrazaderas de acero inoxidable

Cod. 05.090.76

€ 42,00

**ESTRATTORE PER GIUNTI OMOCINETICI  
PULLER FOR HOMOKINETIC JOINTS  
EXTRACTOR DE JUNTAS HOMOCINÉTICAS**

Permette l'estrazione dei giunti omocinetici incastrati e difficilmente rimovibili. Particolarmente indicato per vetture gruppo VAG, Ford, Fiat, CSA, BMW, Mercedes Benz, Suzuki, Volvo, Opel

It allows the extraction of stuck and difficult to remove homokinetic joints. Especially designed for VAG, Ford, Fiat, CSA, BMW, Mercedes Benz, Suzuki, Volvo, Opel group cars

Permite la extracción de juntas homocinéticas pegadas y difíciles de quitar. Especialmente diseñado para los coches del grupo VAG, Ford, Fiat, CSA, BMW, Mercedes Benz, Suzuki, Volvo, Opel. Trabaja directamente sobre el vehículo



**Lavora direttamente sul veicolo**

**It works directly on the vehicle**

**Trabaja directamente sobre el vehículo**





Cod. 05.098.01

€ 46,00

SERIE BUSSOLE SMONTAGGIO TAPPI OLIO MOTORE E PULEGGE DISTRIBUZIONE

1/2" 18 PCS OIL-CHANGE AND DISTRIBUTION PULLEY SOCKET SET

JUEGO DE 18 PIEZAS 1/2" DE LLAVES PARA TAPONES ACEITE MOTOR Y POLEAS DE DISTRIBUCIÓN

Nuovo modello con cricco 3/8" e bussole quadre da:  
New model with 3/8" ratchet and  
Nuevo modelo con trinquete 3/8" y llaves de tubo cuadradas

5/16, 3/8, 7, 8, 10, 11, 12, 13, hasta 14 mm.

Chiavi esagonali da:  
square sockets: 8, 9, 10, 11, 12, hasta 14 mm.  
Llaves hexagonales:

Triangolari:  
Triangular: 10mm  
Triangular:

Quadra incassata:  
Square socket: 10mm  
Llave de tubo:



Cod. 05.062.02

€ 19,00



Pinza per rimozione supporti in gomma per tubazioni di scarico, utilizzabile per una vasta gamma di auto e veicoli commerciali

Pliers for removing rubber supports of exhaust gas systems, suitable for a wide range of cars and commercial vehicles

Alicates para la eliminación de soportes de goma para tuberías de gas de escape, utilizables para una amplia gama de coches y vehículos comerciales

Cod. 02.022.91

€ 22,00

Pinza distacco raccordi rapidi tubi olio-benzina

Pliers for detachment of quick fittings for oil and petrol hoses

Pinza para separación de conexiones rápidas para mangueras de aceite y gasolina



Cod. 05.062.00

€ 98,00

KIT DI 7 PINZE SMONTAGGIO FASCETTE PER TUBI

KIT OF 7 HOSE CLAMP PLIERS

KIT DE 7 ALICATES PARA DESMONTAR ABRAZADERAS TUBOS

Cod. WZRIC0287

€ 28,00



360°

nuova testina rotante



Cod. 03.036.04

€ 13,00

Tanica scarica olio esausto (15lt)  
Temperatura di lavoro -30°/+80°C  
Comode maniglie anteriore e posteriore  
Sufficiente per tutte le applicazioni

Tank to diascharge exhaust oil (15lt)  
Working temperature -30°/+80°C  
Comfortable front and rear handles  
Capacity enough for all the applications

Tanque para la descarga de aceite usado (15lt)  
Temperatura de funcionamiento -30°/+80°C  
Cómodas asas, delantera y posterior  
Suficiente para todas las aplicaciones



Cod. 02.016.04

€ 148,00

**Nuovo kit master per controllo portata di ritorno impianto common rail**

**New kit master for the back flow control of common rail systems**

**Nuevo kit master para el control de la capacidad de retorno de las instalaciones common ra**

Permette un rapido controllo delle portate di iniettori Bosch, Siemens, Delphi dei principali sistemi common rail (auto e veicoli commerciali) identificando eventuali anomalie.

It enables you to perform a quick control of the back flow of the main common rail systems (cars and commercial vehicles) detecting possible anomalies.

Permite un control rápido de las capacidades de retorno de los inyectores Bosch, Siemens, Delphi de las principales instalaciones common rail (coches y vehículos comerciales) detectando posibles anomalías.

**Il kit include:**

1. Rampa con 8 burette graduate, 8 tubi e raccordi dritti per collegamento alle uscite degli iniettori
2. 8 raccordi per iniettori Delphi
3. 24 raccordi a 90° per iniettori Bosch, Siemens, Delphi
4. 8 burette da 10cc per collegamento diretto a iniettori common rail Mercedes.

**The kit includes:**

1. Manifold with 8 graduated burettes, 8 straight hoses and couplings for the connection to the injector outlet.
2. 8 couplings for Delphi injectors
3. 24 90° couplings for injectors iniettori Bosch, Siemens, Delphi
4. 8 10 cc burettes for direct connection to Mercedes common rail injectors

**El kit incluye:**

1. Rampa con 8 buretas graduadas, 8 tubos y empalmes rectos para la conexión a las salidas de los inyectores
2. 8 empalmes para inyectores Delphi
3. 24 empalmes de 90° para inyectores Bosch, Siemens, Delphi
4. 8 buretas de 10cc para la conexión directa a inyectores common rail Mercedes

**HOT!**



Cod. 05.090.70

€ 79,00

**KIT 17PCS FRESE PER SEDI GUARNIZIONI PARAFIAMMA/INIETTORI DIESEL  
17PCS SET OF FIREPROOF SEALS/DIESEL INJECTORS SEAT CUTTERS**

**JUEGO DE 17 PCS DE CORTADORES DE ASIENTO PARA GUARNICIONES IGNIFUGAS/ INYECTORES DIESEL**

- |                     |   |
|---------------------|---|
| 1pc 15.5mm x 15.5mm | fresa angolare/angled reamer/fresadora angular  |
| 1pc 17mm x 17mm     | fresa angolare/angled reamer/fresadora angular  |
| 1pc 17mm x 21mm     | fresa angolare /angled reamer/fresadora angular |
| 1pc 14mm x 14mm     | fresa piana/flat reamer/fresadora regular       |
| 1pc 15mm x 15mm     | fresa piana/flat reamer/fresadora regular       |
| 1pc 15mm x 19mm     | fresa piana/flat reamer/fresadora regular       |
| 1pc 17mm x 17mm     | fresa piana/flat reamer/fresadora regular       |
| 1pc 17mm x 17.5mm   | fresa piana/flat reamer/fresadora regular       |
| 1pc 17mm x 19mm     | fresa piana/flat reamer/fresadora regular       |
| 1pc 17mm x 19.5mm   | fresa piana/flat reamer/fresadora regular       |
| 1pc 17mm x 20mm     | fresa piana/flat reamer/fresadora regular       |
| 1pc 17.5mm x 20.5mm | fresa piana/flat reamer/fresadora regular       |
| 1pc 19mm x 21.5mm   | fresa piana/flat reamer/fresadora regular       |
| 1pc                 | manico a "T"/T-handle/mango en T                |
| 1pc                 | Pilo Post                                       |
| 1pc 15.5mm x 225mm  | fresa/cutter/cortador                           |
| 1pc 2.5mm           | chiave esagonale/hex key/llave hexagonal        |

Cod. 02.020.05

€ 332,00

**POMPA MANUALE**

Per prova iniettori diesel fino a 600 bar

**MANUAL PUMP**

For diesel injector tester up to 600 bars

**BOMBA MANUAL**

Para proba inyectores diesel hasta 600 bar







HOT!

Cod. 04.053.08

€312,00

**KIT TEST POMPA INIEZIONE BENZINA**  
**FUEL INJECTION TEST SET**  
**JUEGO DE HERRAMIENTAS PARA LA PRUEBA DE SISTEMAS DE INYECCIÓN GASOLINA**

Il kit include:

- Gli adattatori più comuni per tutti i tipi di sistemi iniezione benzina
- Ampio manometro con doppia lettura Kpa, Psi da 0 a 1000Kpa (10bar)
- Un manometro di bassa pressione per misurazione accurata da 0 a 100Kpa (1bar)
- Sistema di connessione rapida

Art 060



Cod. 04.043.00

€98,00

**KIT CONTROLLO TENUTA DI GUARNIZIONI**  
**TESTATE MOTORI BENZINA E DIESE**  
**KIT CONTROL SEALS PETROL AND DIESEL ENGINES**  
**CONPROBADOR DE FUGAS DE CULATAS**  
**MOTORES DIESEL Y GASOLINA**

It detects certainly cracks and water leaks on cylinder heads, seals and engine blocks. The test detector will colour immediately, if there are leaks.

Detecta con precisión grietas y pérdidas en las culatas de los cilindros, en las juntas y en el motor. El líquido de prueba se colora automáticamente en caso de no estanqueidad.

Rivela in modo sicuro incrinature e perdite sulle testate cilindri, sulle guarnizioni e sul blocco motore. Il liquido di prova si colora automaticamente nel caso di mancata ermeticità.

Cod. 04.043.01



€32,00

**LIQUIDO DI RICAMBIO**  
**TEST LIQUID (spare part)**  
**LIQUIDO DE RECAMBIO**



Cod. 05.098.02

€71,00

**Kit 114pcs tappi coppa olio e differenziali**

Misure: M13x1,25-M13x1,5-M15x1,5-M17x1,5-M20x1,5-M22x1,5mm

**Kit of 114pcs oil pan and differential caps**

Sizes: M13x1,25-M13x1,5-M15x1,5-M17x1,5-M20x1,5-M22x1,5mm

**Kit 114pcs de tapas para cárter de aceite y diferenciales**

Tallas: M13x1,25-M13x1,5-M15x1,5-M17x1,5-M20x1,5-M22x1,5mm



Cod. 04.029.01

€102,00

**KIT OIL PRESSURE**  
**TESTER PRUEBA PRESIONES ACEITE MOTOR**  
**TESTER PROVA PRESSIONE OLIO MOTORE**

- Double-range gauge easily reading up to 10 bar
- Rapid couplings with valves to work safely and quickly
- Manómetro con doble escala, lectura fácil, hasta 10 bar
- empalmes rápidos con válvulas para trabajar en seguridad y rápidamente
- Manometro doppia scala di facile lettura fino a 10 bar
- Attacchi rapidi con valvole per operare in sicurezza e velocità



Cod. 05.090.47

€ 119,00



**KIT RIMOZIONE CANDELETTE ROTTE  
GLOW PLUG DRILLING SET**

**KIT DE EXTRACCION DE BUJIAS DE PRECALENTAMIENTO**

Semplice estrazione di candele  
danneggiate o ingrippate su molti  
moderni motori diesel  
Non necessaria la rimozione della  
testa del cilindro che potrebbe  
danneggiare lo stampo  
Adatto a motori diesel Mercedes  
Benz CDI

Easy extraction of the damaged/  
seized glow plugs on many  
modern diesel engines  
No cylinder head extraction  
needed which may cause damages  
to cylinder head castings  
Suitable for Mercedes Benz CDI  
diesel engines

Extracción fácil de las bujías  
dañadas / gripadas en muchos  
motores diesel modernos  
No extracción de la culata  
necesaria que puede causar daños  
a la fundición de la culata  
Adecuado para motores diesel  
Mercedes Benz CDI

Cod. 05.090.07

€ 62,00



**Misure disponibili**  
**Available sizes**  
**Tamaños disponibles:**

8 mm L=155mm;	10 mm L=155mm;
9 mm L=155mm;	11 mm L=155mm;
	12 mm L=155mm;
	14 mm L=155mm;
	16 mm L=155mm;



**SERIE DI 6 BUSSOLE SNODATE PER CANDELETTE (LUNGHE)**

Per uno smontaggio sicuro delle candele anche in posizioni difficili da raggiungere. Includono anello in gomma per mantenimento candele.

**KIT 6 JOINTED SOCKETS FOR PLUGS (LONG)**

To dismount safely the plugs also those positioned in difficult positions to be reached. It includes a rubber ring to hold the plug.

**KIT DE 6 CASQUILLOS PARA BUJÍAS (LARGOS)**

Para desmontar en seguridad las bujías que están colocadas en zonas difíciles de llegar. Incluye un anillo de goma para la bujía.



**HOT!**

Cod. 04.024.02

€ 202,00

**Nuova pompa vuoto e pressione "Mytivac"  
New vacuum and pressure pump "Mytivac"  
Nueva bomba de vacío y presión "Mytivac"**

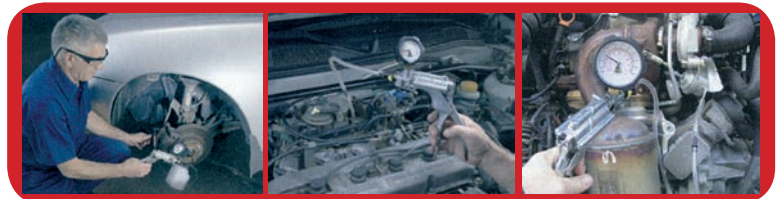

Maggiori prestazioni (-1/+4 bar)  
Manometro con protezione in gomma rotante a 360° A  
Selezione vuoto-pressione con una sola mano  
Impugnatura ergonomica C  
Contenitore olio freni esaurito collegato direttamente alla pompa B

Better performance (-1/+4 bar)  
Gauge with rubber protection rotating 360° A  
Selection vacuum-pressure with only one hand  
Hergonomical handle C  
Exhausted brake oil recipient connected directly to the pump B

Mayores prestaciones (-1/+4 bar)  
Manómetro con protección de caucho giratorio de 360° A  
Selección vacío-presión con una mano sola  
Empuñadura ergonómica C  
Recipiente de aceite frenos usado conectado directamente a la bomba B



Cod. 04.024.01

€ 118,00

**POMPA A VUOTO E PRESSIONE (-1/3 BAR)  
Completa di accessori in valigetta ABS**

**VACUUM-PRESSURE PUMP (-1/3 BAR)  
Supplied with accessories in ABS case**

**BOMBA MANUAL PRESIÓN-DEPRESIÓN (-1/3 BAR)  
Con accesorios en maletín de ABS incluidos**



Cod. 05.090.08

€ 68,00

**ESTRATTORI  
PER INIETTORI  
COMMON RAIL.**

**Il kit include:**  
Martello a battente  
(Kg 1,75 ),  
adattatore M17x1.0  
Adattatore M27x1.0  
per iniettore CR Bosch,  
adattatore M12x1,75  
In valigetta antiurto.

**9 PCS  
COMMON RAIL  
INJECTORS  
EXTRACTOR SET**

**The kit includes:**  
Slide Hammer  
(Kg 1,75),  
adaptor M17x1.0,  
adapter M27x1 fro  
Bosch injector head,  
Adapter with M12x1,75.  
Blow mould case  
included.

**JUEGO DE 9 PIEZAS  
DE EXTRACTORES  
INYECTORES  
COMMON RAIL**

**El juego incluye:**  
Martillo de oscilacion  
(Kg 1,75),  
Adaptador M17x1.0,  
Adaptador M27x1 para  
la cabeza del inyector  
Bosch,  
Adaptador con M12x1,75.  
Caja a prueba de  
choques incluida.



Cod. 04.053.05

€ 428,00

**038K9M/3000**

**Prova compressione Diesel  
(anche Common Rail)**

**Compression Tester for Diesel  
(also Common Rail)**

**Tester prueba compresión Diesel  
(también Common Rail)**

Applicazioni / Applications / Aplicaciones:

Alfa Romeo, BMW, Chrysler, Daewoo, Fiat, Ford, Hyundai, ISU24,  
Landrover, LDV, Mazda, Mercedes, Mitsubishi, Nissan, Opel, PSA,  
Renault, SAAB, Suzuki, Toyota, VAG, Vauxhall, Volvo  
Injectors: M20, M22, M24 e Ford Stanadyne TDI Injectors



Cod. 04.053.00

€ 69,00

**038K6M/3000**

**TESTER PROVA COMPRESIONE  
MOTORI BENZINA CON MANOMETRO  
0-20BAR (PSI).**

**IL KIT INCLUDE:**

attacco M10x1,0 (moto),  
attacco M12x1,25 (moto),  
attacco M14x1,25 (2 pezzi),  
attacco M18x1,5,  
maschio per filetti M10/M12,  
maschio per filetti M14/M18.

**COMPRESSION TESTER FOR PETROL  
ENGINES WITH MANOMETRO  
0-20BAR.**

**THE KIT INCLUDES:**

M10x1,0 coupling (motorcycles),  
M12x1,25 coupling (motorcycles),  
M14x1,25 coupling (2 pieces),  
M18x1,5 coupling,  
male for threads M10/M12,  
male for threads M14/M18.

**TESTER PRUEBA COMPRESIÓN MOTORES  
DE GASOLINA CON MANÓMETRO  
0-20BAR (PSI).**

**EL KIT INCLUYE:**

empalme M10x1,0 (moto),  
empalme M12x1,25 (moto),  
empalme M14x1,25 (2 unidades),  
empalme M18x1,5,  
macho para filetes M10/M12,  
macho para filetes M14/M18.

**Coppia barre di estensione per prova compressione 12/14mm**

**Compression test adaptors (2pcs) 12/14mm**

**Adaptadores de prueba de compresión (2pcs) 12 / 14mm**



Questo adattatore extra lungo per prova compressione è progettato per adattarsi a candele di 12/14mm  
Questo utensile è essenziale su BMW E90 335i con motori N54 >2006, BMW MINI, MERCEDES M156, FORD DURATECH 16V  
Utilizzabile anche su motori Peugeot 207/307 e Renault 1.2 16 valvole  
Design speciale per estendere la filettatura delle candele in sede profonda per facilitare i test

This extra-long compression test adaptor is designed to fit 12 and 14mm spark plugs  
This tool is now essential on BMW E90 335i with N54 engine 2006, BMW MINI, MERCEDES M156, FORD DURATECH 16V  
Also used on Peugeot 207/307 and Renault 1.2 16 valve engines  
Special design to extend the spark plug thread in the deep hole for easier testing

Este adaptador de prueba de compresión extra largo está diseñado para adaptarse a bujías de 12 y hasta 14 mm. Este instrumento es ahora esencial sobre BMW E90 335i con motor N54 2006, BMW MINI, MERCEDES M156, FORD DURATECH 16V. También se utiliza en Peugeot 207/307 y Renault 1.2 motores de 16 válvulas.  
Diseño especial para extender el hilo de la bujía en el agujero profundo para pruebas más fáciles.

Cod. 04.053.07

€ 43,00





600 Kg



Foto indicativa / Indicative picture

Cod. 05.085.09

€ 1.498,00

**PONTE SOLLEVATORE  
PER MOTO/QUAD  
CON POMPA ARIA/OLIO**

**AIR-HYDRAULIC  
MOTORCYCLE/QUAD LIFTER**

**ELEVADOR POR  
AIRE/HIDRÁULICO  
PARA MOTOCICLETA/QUAD**

**CARATTERISTICHE TECNICHE**

- Capacità: 600 Kg
- Altezza min: 180 mm
- Altezza max: 830 mm
- Misura piano: 195x122cm (con appendici laterali)
- Misura rampa: 58x122cm (con appendici laterali)
- Range pressione operativa: 7,5 - 8,5 Bar
- Imballo in legno
- Dimensione imballi: 203x80x50cm
- Peso lordo: 260kg
- Peso netto: 230kg
- Colore: Blu Ral 5015
- Tempi di consegna: 75 giorni

**TECHNICAL FEATURES**

- Capacity: 600 Kg
- Min.Height: 180 mm
- Max.Height: 830 mm
- Table size: 195x122cm (with side plate)
- Ramp size: 58x122cm (with side plate)
- Air pressure: 7,5 - 8,5 Bar
- Plywood Cases
- Package size: 203x80x50cm
- G.W.: 260kg
- N.W.: 230kg
- Color: Blue Ral 5015
- Delivery time: 75 days

**CARACTERÍSTICAS TÉCNICAS**

- Capacidad: 600 Kg
- Altura Min.: 180 mm
- Altura Max.: 830 mm
- Tamaño de la superficie de apoyo: 195x122cm (con placa lateral)
- Tamaño de la rampa: 58x122cm (con placa lateral)
- Presión del aire: 7,5 - 8,5 bar
- Embalaje Plywood
- Tamaño del embalaje: 203x80x50cm
- Peso bruto: 260kg
- Peso neto: 230kg
- Color: Azul Ral 5015
- Tiempo de entrega: 75 dias

**HOT!**



Foto indicativa / Indicative picture

Cod. 05.085.04 L

€ 620,00

**Ponte sollevatore per moto e scooter  
con pompa idraulica a pedale**

**Lift for motorcycles & scooters  
equipped with foot hydraulic pump**

**Levantador hidráulico de peso  
accionado por pie para motos y scooters**

**CARATTERISTICHE TECNICHE**

- Capacità: 450 Kg
- Altezza min: 18,5 cm
- Altezza max: 85 cm
- Misura piano con rampa laterale: 266x65 cm
- Misura piano: 206x65 cm
- Misura rampa laterale: 60x65 cm
- Dimensione imballi: 224x70x21 cm
- Imballo in legno
- Peso lordo: 167,8kg
- Peso netto: 145,5kg
- Colore: Blu Ral 5015

**TECHNICAL FEATURES**

- Capacity: 450 Kg
- Min.Height: 18,5 cm
- Max.Height: 85 cm
- Table size with side ramp: 266x65cm
- Table size: 206x65cm
- Side ramp size: 60x65cm
- Package size: 224x70x21 cm
- Plywood Cases
- G.W.: 167,8kg
- N.W.: 145,5kg
- Color: Blue Ral 5015

**CARACTERÍSTICAS TÉCNICAS**

- Capacidad: 450 Kg
- Altura Min.: 18,5 cm
- Altura Max.: 85 cm
- Tamaño de la superficie de apoyo con placa lateral: 266x65cm
- Tamaño de la superficie de apoyo: 206x65cm
- Placa lateral: 60x65 cm
- Tamaño del embalaje: 224x70x21 cm
- Embalaje Plywood
- Peso bruto: 167,8kg
- Peso neto: 145,5kg
- Color: Azul Ral 5015



Foto indicativa / Indicative picture

Cod. 05.085.04 C

€ 534,00

**Ponte sollevatore per moto e scooter  
con pompa idraulica a pedale**

**Lift for motorcycles & scooters  
equipped with foot hydraulic pump**

**Levantador hidráulico de peso  
accionado por pie para motos y scooters**

**CARATTERISTICHE TECNICHE**

- Capacità: 360Kg
- Altezza min: 20 cm
- Altezza max: 85 cm
- Misura piano con rampa laterale: 220x49 cm
- Misura piano: 135x49 cm
- Misura rampa laterale: 85x49cm
- Dimensione imballi: 150x80x40 cm
- Imballo in legno
- Peso lordo: 120 kg
- Peso netto: 107 kg
- Colore: Blu Ral 5015

**TECHNICAL FEATURES**

- Capacity: 360 Kg
- Min.Height: 20 cm
- Max.Height: 85 cm
- Table size with side ramp: 220x49 cm
- Table size: 135x49 cm
- Side ramp size: 85x49cm
- Package size: 150x80x40 cm
- Plywood Cases
- G.W.: 120 kg
- N.W.: 107 kg
- Color: Blue Ral 5015

**CARACTERÍSTICAS TÉCNICAS**

- Capacidad: 360 Kg
- Altura Min.: 20 cm
- Altura Max.: 85 cm
- Tamaño de la superficie de apoyo con placa lateral: 220x49 cm
- Tamaño de la superficie de apoyo: 135x49 cm
- Placa lateral: 85x49cm
- Embalaje Plywood
- Tamaño del embalaje: 150x80x40 cm
- Peso bruto: 120 kg
- Peso neto: 107 kg
- Color: Azul Ral 5015





Cod. 05.085.05

€ 184,00

**SOLLEVATORE IDRAULICO A PEDALE  
PER SCOOTER E MOTO DA CROSS**

**FOOT HYDRAULIC WEIGHT LIFTER FOR SCOOTERS AND ENDUROS**

**LEVANTADOR HIDRÁULICO DE PESO ACCIONADO POR PIE  
PARA MOTOS Y ENDUROS**

CARATTERISTICHE TECNICHE	TECHNICAL FEATURES	CARACTERÍSTICAS TÉCNICAS
Capacità: 135kgs	Load range: 135kgs	Capacidad: 135kgs
Altezza minima: 340mm	Minimum height: 340mm	Altura mínima: 340 mm
Altezza massima: 890mm	Maximum height: 890mm	Altura máxima: 890mm
Peso: 28,5kgs	Weight: 28,5kgs	Peso: 28,5kgs

**CAVALLETTO SPOSTA MOTO IN ACCIAIO VERNICIATO  
MOVABLE MOTORCYCLE STAND IN PAINTED STEEL  
SOPORTE MÓVIL PARA MOTOCICLETAS EN ACERO PINTADO**

Cod. 05.085.10

€ 186,00



Permette di posteggiare e spostare in spazi ristretti (officine/show room) scooter e moto di grossa cilindrata dotate di cavalletto laterale

It allows to park and move in confined spaces (workshops/showrooms) scooters and big bikes equipped with side stands

Permite aparcar y mover en espacios confinados (talleres/salas de exposición) scooters y motocicletas equipadas con soportes laterales

**Caratteristiche tecniche**

Portata: 570kgs  
Materiale: acciaio verniciato  
Max lunghezza: 200cm  
Max larghezza: 20cm  
5 ruote da 2" doppie piroettanti  
Dim. Max attrezzo montato: 211x80x9cm  
Dim. Imballo: 198x31x9cm  
Peso netto/lordo: 30/31.5kgs

**Technical features**

Capacity: 570kgs  
Material: painted steel  
Max length: 200cm  
Max width: 20cm  
5 x 2" double castor wheels  
Max dim. assembled device: 211x80x9cm  
Packaging Dim.: 198x31x9cm  
Net/gross weight: 30/31.5kgs

**Características técnicas**

Capacidad: 570kgs  
Material: acero pintado  
Longitud máxima: 200cm  
Ancho máximo: 20 cm  
5 x 2" ruedas pivotantes dobles  
Dim. Maxima dispositivo montado: 211x80x9cm  
Embalaje Dim.: 198x31x9cm  
Peso bruto/neto: 30/31.5kgs

**SDRAIOTTI SOTTO MACCHINA HEAVY DUTY CREEPERS COUCHETTES DE TRAVAIL  
KFZ MECHANIKER ROLLBRETTEN CAMILLAS DE MECÁNICO**

Cod. 05.083.00

€ 48,00

- Cuscino poggiatesta regolabile per il massimo comfort di lavoro
- 6 ruote piroettanti in gomma antiolio
- Misure: 1020x430x180mm
- Adjustable pneumatic headrest for maximum head and shoulder comfort
- 6 pivoting wheels (anti-oil corrosion)
- Size: 1020x430x180mm



**HOT!**

Plastica di alta densità  
High-density polyethylene  
Molto resistente  
High resistance

Cod. 05.083.01

€ 44,00

Capienza 150 kg  
Max. weight load 150 kg  
Misure (cm): 102x12xh48cm  
Size (cm): 102x12xh48



Cod. 05.087.14

€ 120,00



**FOLDING ALUMINIUM LADDER**  
**ESCALERA PLEGABLE**  
**DE ALUMINIO**  
**RAMPA DI CARICO PIEGHEVOLE**  
**IN ALLUMINIO**



Total length:	Longitud total:	Lunghezza totale:	199cm
Folded ladder:	Escalera plegada:	Rampa chiusa:	72cm
Load range:	Capacidad:	Portata:	270kgs
Width:	Ancho:	Larghezza:	30cm
Weight:	Peso:	Peso:	7kgs

Cod. 05.087.03

€ 129,00



**Coppia rampe in alluminio**  
**Pair of aluminum ramps**  
**Pareja de rampas de aluminio**

Dimensions: 151x24x5cm  
Peso: 7 kg  
con imballo with packaging con embalaje  
Portata Capacity Capacidad: 400 kg



**RAMPA IN ALLUMINIO**  
**RICHIUDIBILE E TRASPORTABILE**

**ALUMINUM CLOSABLE AND PORTABLE RAMP**

**RAMPA DE ALUMINIO RECERRABLE Y PORTÁTIL**

Cod. 05.087.04

€ 149,00

Peso: 9,5kg (11,5 kg con imballo) / Weight: 9,5kg (11,5 kg with packaging)  
Portata/Capacity/ Capacidad: 270 kg  
123x38x8cm

*new model*

Cod. 05.087.16

€ 230,00

Peso: 18kg (20,5 kg con imballo) / Weight: 18kg (20,5 kg with packaging)  
Portata/Capacity/ Capacidad: 300 kg  
185x38x8cm



Utenti:  
officine moto,  
motori marini

Main final users:  
motor cycles workshops,  
marine engine workshops

Utilisateurs:  
garage motos,  
moteurs marins

Cod. 05.049.00

€ 196,00

**SINCRONIZZATORE**

per carburatori a 4 vacuometri completo di tubi e attacchi.

**CARBURETTOR'S SYNCHRONIZER,**  
with 4 vacuum-meters, complete with hoses and fittings.

**SYNCHRONISEUR**

pour carburateur avec 4 vacuo-mètres, complets de tuyaux est raccords.

**GLEICHLAUFEINRICHTUNG**

für Vergaser mit 4 Vakuummessern, komplett mit Schläuchen und Fittings.

**SINCRONIZADOR**

para carburadores con 4 vacuómetros con tubos y empalmes.

Hauptsächliche  
Endverbraucher:  
Motorradwerkstätten,  
Werkstätten für Bootsmotore

Usuarios:  
talleres para motocicletas,  
talleres para motores náuticos



Cod. 05.090.62

€ 40,00

**Set 11 chiavi combinate**  
**Kit of 11 combined wrenches**  
**Juego de 11 llaves combinadas**

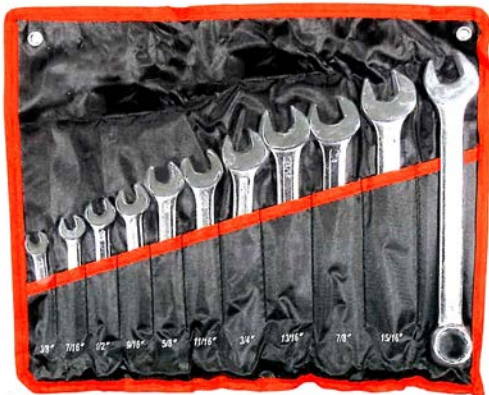

3/8",  
7/16",  
1/2",  
9/16",  
5/8",  
11/16",  
3/4",  
13/16",  
7/8",  
15/16",  
1"

Cod. 05.090.64

€ 65,00



**Set 10 estrattori rotore**

**Kit of 10 rotor's extractors**

**Kit de 10 extractores rotor**

(Honda, Suzuki, Yamaha, Bosch, Ducati, Kawasaki)

Cod. 03.031.13

€ 328,00

**SMONTAMOLLE PER MOTO**  
**SPRING COMPRESSOR FOR MOTORCYCLES**

**EXTRACTOR DE MUELLES PARA MOTOCICLETAS**

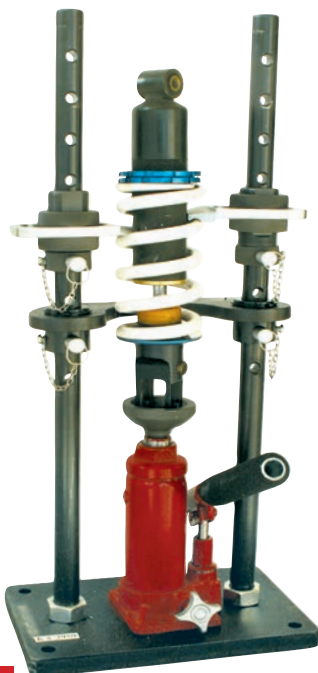

H max.	390mm	{ tra le spire, among the spirals, entre las espiras             }
H min.	8mm	
Ø max	100mm	
Ø min.	30mm	

Utilizzabile su ogni tipo di ammortizzatore

Suitable for all types of shock-absorbers

Se puede utilizar con todos los tipos de amortiguadores

Cod. 05.090.63

€ 38,50



**Set per la separazione e rivettatura di catene motocicli**

idoneo per catene da 35 a 630  
3 punti di separazione (2,2mm, 2,9mm 3,8mm)

**Set for the separation and riveting of motorcycles chains**

suitable for chains from 35 to 630  
3 points of separation (2.2mm, 3.8mm 2.9mm)

**Conjunto para la separación y el remachado de las cadenas de motocicletas**

apto para cadenas de 35 a 630  
3 puntos de separación (2,2mm, 3,8mm 2,9mm)

Cod. 05.090.65

€ 78,00

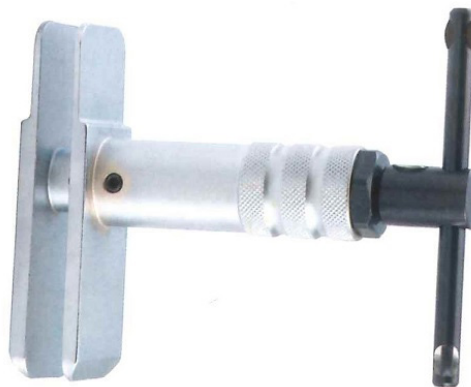

**Distanziatore per pinze freni**

**Spacer for brake clamps**

**Espaciador para pinzas freno**

Cod. 05.085.07

€ 70,00

**Cavalletto ferma moto**  
**Motorcycle stand**  
**Soporte para motocicletas**

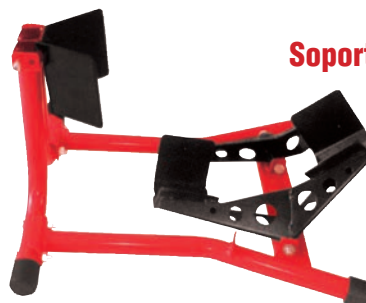

Portata/Capacity/Capacidad:  
200 kgs

Packaging dimensions:  
Dimensioni imballo:  
640x540x160mm

Weight/Peso:  
11,5kgs



Cod. 05.086.00

€ 179,00

**LINEA EASY STEP**

Scale per la manutenzione industriale e l'assistenza tecnica in genere

Ladders for industrial maintenance and general technical assistance

Escaleras para el mantenimiento industrial y la asistencia técnica general



Compatta  
(95cm di altezza minima)  
Si chiude e si apre in un minuto  
Altezza massima 3,80 mt  
Nuovo modello con dispositivo "salvadita"

Compact  
(95cm minimum height)  
You open and close it in 1 minute  
Maximum height 3,80 mt  
New model with "finger-saving" device

Compacto  
(95 cm Altura mínima)  
Se abre y se cierra en 1 minuto  
Altura máxima de 3,80 mt  
Nuevo modelo con dispositivo de "ahorro de dedos"

EN131

IN COMPLIANCE WITH EN CONFORMIDAD CON EN CONFORMITÉ AVEC ATTREZZATURE A NORMA

Cod. 05.086.05

€ 129,00

**Easy Step Home**

Per uso privato o professionale  
For private and professional use  
Para uso privado y profesional



Altezza massima: / Maximum height: / Altura máxima:	2,60mt
Altezza minima: / Minimum height: / Altura mínima:	83cm
Portata: / Capacity: / Capacidad:	150kg
Peso: / Weight: / Poids:	6 kg

EN131

IN COMPLIANCE WITH EN CONFORMIDAD CON EN CONFORMITÉ AVEC ATTREZZATURE A NORMA

**Scala multiposizione  
Multi-position ladder  
Escalera multiposición**

Cod. 05.086.04

€ 92,00

Maximum height: / Altura máxima: / Altezza massima:	3,1 mt
Hauteur minimum: / Altura mínima: / Altezza minima:	1,03 mt
Nr. de marches: / Nr. de pasos: / No. Scalini:	4x3
Standing base: / Base de pie: / Base appoggio:	470 mm
Capacity: / Capacidad: / Portata:	150kg
Weight: / Peso:	12kg



HOT!

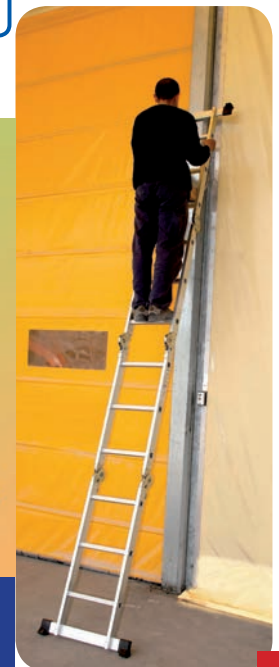
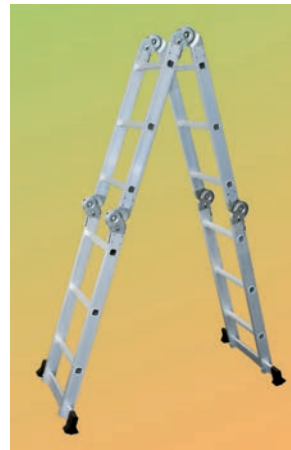

EN131

IN COMPLIANCE WITH EN CONFORMIDAD CON EN CONFORMITÉ AVEC ATTREZZATURE A NORMA

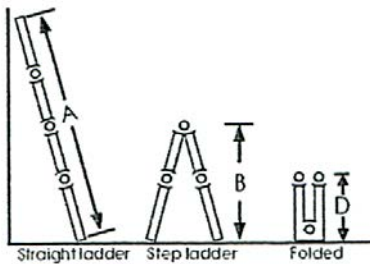

**EN131** IN COMPLIANCE WITH EN CONFORMIDAD CON EN CONFORMITÉ AVEC ATTREZZATURE A NORMA



	STEP	A SIZE (MM)	B SIZE (MM)	D SIZE (MM)	
<b>Cod. 05.086.14</b>	4x3	2900	1420	940	€ 128, <sup>00</sup>
<b>Cod. 05.086.15</b>	4x4	3840	1940	1220	€ 155, <sup>00</sup>
<b>Cod. 05.086.16</b>	4x5	5100	2460	1500	€ 194, <sup>00</sup>

**Cod. 05.087.13**

**€ 102,<sup>00</sup>**



**Pedana in alluminio**  
**Aluminium platform**  
**Plataforma de aluminio**

per carrozzerie,  
officine  
meccaniche,  
artigiani,  
edilizia,  
manutentori

for body parts  
workshops,  
mechanic  
workshops,  
artisans,  
maintenance  
technicians

para chapistas,  
talleres mecanicos,  
tecnicos  
de mantenimiento

Portata:	Load range:	Rango de carga:	200kgs
Dimensioni:	Dimensions:	Dimensiones:	1016x410x585mm
Peso:	Weight:	Peso:	28,16kgs

**EN131** IN COMPLIANCE WITH EN CONFORMIDAD CON EN CONFORMITÉ AVEC ATTREZZATURE A NORMA





**SCALA IN ALLUMINIO**  
TIPO DOMESTICO

**ALUMINUM LADDER**  
HOUSEHOLD TYPE

**ESCALERA DE ALUMINIO**  
TIPO DOMÉSTICO

**3 gradini/steps/escalones/marches**

Cod. 05.086.11

€ 28,<sup>90</sup>

**6 gradini/steps/escalones/marches**

Cod. 05.086.12

€ 49,<sup>50</sup>

**EN131**

IN COMPLIANCE WITH  
EN CONFORMIDAD CON  
EN CONFORMITÉ AVEC  
ATTREZZATURE A NORMA

Materiale: alluminio

Larghezza gradino: 80mm

Portata: 150kg

Peso: 6,3/9,64kg

Material: aluminum

Step width: 80mm

Capacity: 150kg

Weight: 6,3/9,64kg

Material: aluminio

Anchura del escalon: 80mm

Capacidad: 150 kg

Peso: 6,3/9,64kg

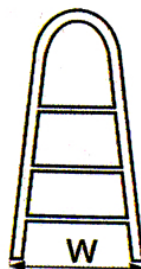
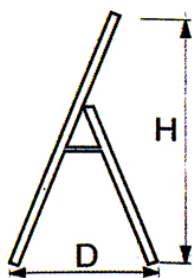

	3 gradini steps escalones marches	6 gradini steps escalones marches
Dimensioni: Dimensions: Dimensiones: Dimensions:	W=405mm, D=610mm, H=1110mm	W=450mm, D=850mm, H=1740mm
Dimensioni imballo: Package dimensions: Dimensiones del embalaje: Dimensions de l'emballage:	118x33x24cm	181x36,5x24cm

ATTREZZATURE PER CARROZZERIE  
CAR BODY SHOPS EQUIPMENT  
EQUIPO PARA CHAPA Y PINTURA





NEW!  
2018



Cod. 05.090.85

€ 22,00

**SPESSIMETRI PER CARROZZERIA**  
a 10 lame con ventosa di fissaggio (2 pz)  
per posizionamento cristalli

**10-BLADE BODY THICKNESS GAUGES**  
with fixing suction cup (2 pcs) for windows positioning

**MEDIDORES DE ESPESOR DE CARROCCERIA**  
de 10 cuchillas con ventosa de fijación (2 piezas)  
para el posicionamiento de cristales

NEW!  
2018

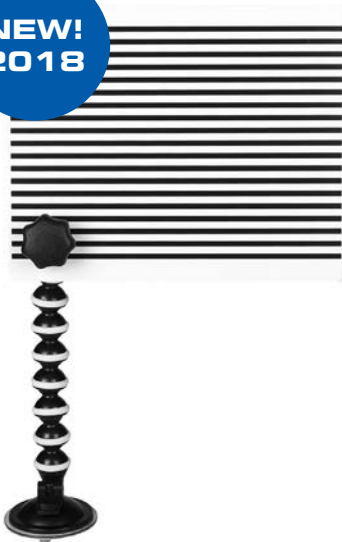

Cod. 05.090.86

€ 50,00

**PANNELLO DI RISCONTRO BOLLE**  
**DI CARROZZERIA, CON VENTOSA**  
Permette di rilevare le più piccole imperfezioni della  
carrozzeria, con ventosa

**DENT REPAIR PANEL WITH SUCTION CUP**  
**FOR CAR BODIES**  
It allows to detect the smallest imperfections on the car body

**PANEL DE REPARACIÓN DE ABOLLADURAS**  
**DE CARROCCERIA, CON VENTOSA**  
Permite detectar las imperfecciones más pequeñas  
en la carrocería del automóvil, con ventosa



Cod. 05.074.05

€ 190,00

**Misuratore spessore vernici**  
**Digital paint thickness indicator**  
**Indicador digital espesor de pintura**

Utilizzabile su superfici in acciaio e alluminio  
Campo di misura: 0-1900mm  
Precisione: +/- 10 mm  
Riconoscimento automatico del supporto  
Sonda esterna con tastatore adatta anche a  
superfici irregolari  
2 kit di calibrazione  
Fabbricato in UE

It can be used on aluminum and steel  
surfaces  
Measuring range: 0-1900mm  
Precision: +/- 10mm  
Automatic detection of the material  
External probe, it can be used on irregular  
surfaces  
2 calibration kits  
Made in EU

Se puede utilizar sobre superficies de  
aluminio y acero  
Intervalo de medida: 0-1900mm  
Precisión: +/- 10 mm  
Detección automática del material  
Sonda externa, se puede utilizar en superfi-  
cies irregulares  
2 kit de calibración  
Fabricado en la UE

Cod. 05.066.01

€ 296,00

**ATTREZZO LEVABOLLI PNEUMATICO CON 10 VENTOSE  
PNEUMATIC PULLER WITH 10 SUCTION CUPS  
TIRADOR NEUMÁTICO CON 10 VENTOSAS  
EXTRACTEUR PNEUMATIQUES AVEC 10 VENTOUSES**

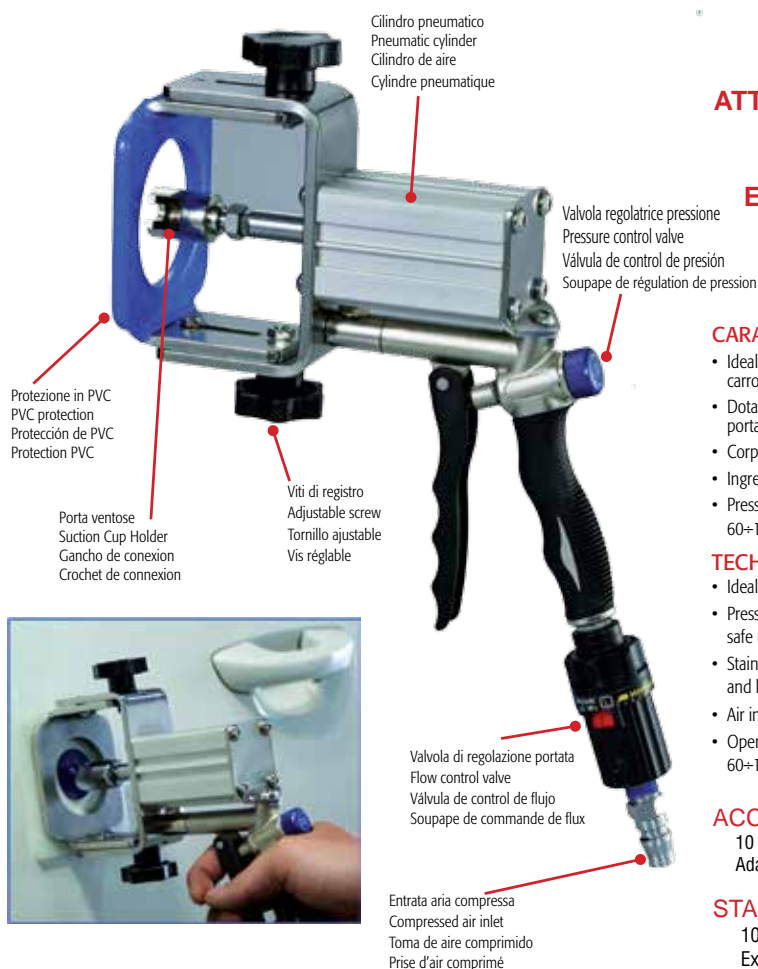

**CARATTERISTICHE TECNICHE:**

- Ideale per la riparazione di piccole bolle di carrozzeria
- Dotata di regolatori di pressione e regolatore di portata
- Corpo in acciaio inox con piano d'appoggio in PVC
- Ingresso aria 1/4"
- Pressione 4÷12 bar (0,4 - 1,2 MPa) 60÷175 psi

**TECHNICAL SPECIFICATIONS:**

- Ideal for repairing small vehicle body damages
- Pressure regulator and flow control valve for a safe usage
- Stainless steel with PVC protection for high quality and long life
- Air inlet: 1/4"
- Operating pressure 4÷12 bar (0,4 - 1,2 MPa) 60÷175 psi

**ACCESSOIRES STANDARD**

- 10 ventouses en plastique
- Adaptateur d'extension

**STANDARD ACCESSORIES**

- 10 plastic suction cups
- Extension adapter

**CARACTERÍSTICAS TÉCNICAS:**

- Ideal para la reparación de daños pequeños sobre el vehículo
- Regulador de presión y válvula de control de flujo para un uso seguro
- Acero inoxidable con protección de PVC de alta calidad y larga vida
- Entrada de aire: 1/4"
- Presión de trabajo 4 ÷ 12 bar (0,4 - 1,2 MPa) 60 ÷ 175 psi

**CARACTÉRISTIQUES TECHNIQUES:**

- Idéal pour la réparation de petits dommages de carrosserie
- Régulateur de pression et soupape de commande de flux pour une utilisation en toute sécurité
- Acier inoxydable avec protection PVC de haute qualité et longue durée
- Prise d'air: 1/4"
- Pression de fonctionnement 4÷12 bar (0,4 - 1,2MPa) 60÷175 psi

**ACCESORIOS ESTÁNDAR**

- 10 ventosas de plástico
- Adaptador de extensión

**ACCESSORI STANDARD**

- 10 ventose in plastica
- Adattatore di estensione

Cod. 05.066.05

€ 16,00

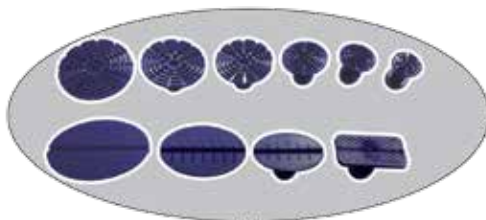

- Kit 10 adattatori (ricambio)
- 10 adaptors kit (spare parts)
- Kit de 10 adaptadores (repuestos)
- Kit 10 adaptateurs (pièces de rechange)

Cod. 05.066.03

€ 21,60



**PISTOLA TERMOCOLLANTE  
THERMOBINDING GUN**

PISTOLA TERMOCOLLANTE CON AVANZAMENTO AUTOMATICO, CON LED CHE SEGNA LA PISTOLA È COLLEGATA ALLA RETE ELETTRICA

THERMOBINDING GUN WITH AUTOMATIC ADVANCEMENT, EQUIPPED WITH A LED SIGNALLING IF THE GUN IS CONNECTED TO THE ELECTRICITY GRID

**PISTOLA ENCOLADORA  
PISTOLET THERMOCOLLANT**

PISTOLA ENCOLADORA CON PROGRESO AUTOMÁTICO, EQUIPADA CON LED PARA SEÑALAR SI LA PISTOLA ESTÁ CONECTADA A LA RED ELÉCTRICA

PISTOLET THERMOCOLLANT AVEC AVANCEMENT AUTOMATIQUE, ÉQUIPÉ AVEC UN LED POUR SIGNALER SI LE PISTOLET EST CONNECTÉ À LE RÉSEAU ÉLECTRIQUE

**TECHNICAL FEATURES**

- Power supply 220V 35W, 200°C
- Stick glue Ø 12mm
- Glue flow 16 ÷ 20 g/min
- Weight 413g
- Packaging 24

Cod. 05.066.04

€ 6,86



**CANDELETTE DI COLLA PER PISTOLA TERMOCOLLANTE  
GLUE CANDELS FOR THERMOBINDING GUN  
VELAS DE PEGAMENTO PARA PISTOLA ENCOLADORA  
BÂTONS DE COLLE POUR PISTOLET THERMOCOLLANT**

**TECHNICAL FEATURES**

- Colour Black/ Couleur Noir
- Dimensions 10pcs Ø 12 x 200mm 200g
- Packaging 10\*/30

**STACCAVETRI PNEUMATICO**

Il KIT **PLUS** include 12 lame  
**BASE** con 1 lama



MADE IN TAIWAN

**BASE**

Cod. 05.091.00

€ 150,00

**PNEUMATIC KIT TO REMOVE WINDOWS**

The KIT **PLUS** includes 12 blades  
**BASE** Includo 1 blade

**HERRAMIENTA PARA DESMONTAR CRISTALES NEUMÁTICA**

El KIT **PLUS** incluye 12 hojas  
**BASE** Equipado con 1 hoja



MADE IN TAIWAN

**PLUS**

Cod. 05.091.01

€ 298,00

Cod. 05.091.02

€ 103,00

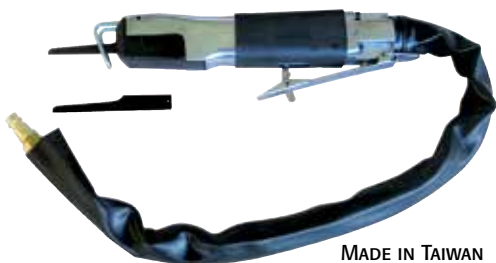

MADE IN TAIWAN

- ✓ Velocità: 9.000 rpm/min
- ✓ Lunghezza: 235 mm
- ✓ Peso: 770 g
- ✓ Consumo aria: 120 L/min
- ✓ Pressione aria: 6,3 bar
- ✓ Livello rumore: 72,0 dB (a)
- ✓ Accelerazione: 26,0 m/ s2
- ✓ Max. capacità taglio: 1,2 mm

**Seghetto pneumatico**

**Air Car Body Saw**

**Sierra de aire**

- ✓ Free speed: 9.000 rpm/min
- ✓ Length: 235 mm
- ✓ Weigth: 770 g
- ✓ Air consumption: 120 L/minute
- ✓ Air pressure: 6,3 bar
- ✓ Noise level: 72,0 dB (a)
- ✓ Acceleration: 26,0 m/ s2
- ✓ Max. cutting capacity: 1,2 mm

- ✓ Velocidad libre: 9.000 rpm/min
- ✓ Longitud: 235 mm
- ✓ Peso: 770 g
- ✓ Consumo de aire: 120 l/min
- ✓ Presión del aire: 6,3 bar
- ✓ Nivel de ruido: 72,0 dB (a)
- ✓ Aceleración: 26,0 m / s2
- ✓ Max. capacidad de corte: 1,2 mm

Cod. 05.090.25

€ 45,00

**Kit smontaggio airbag (12 pz.)**  
**12 pcs. air bag removal tool set**  
**Airbags Kit de démantèlement (12 pcs.)**  
**Kit para desmontar el airbag (12 pzas.)**



Cod. 05.066.02

€ 55,00

**SET SVERNICIATORE**  
**PAINT REMOVER SET**



**SET PARA ELIMINACION DE PINTURA**  
**SET DÉCAPANT DE PEINTURE**

CARATTERISTICHE TECNICHE TECHNICAL FEATURES CARACTERÍSTICAS TÉCNICAS CARACTÉRISTIQUES TECHNIQUES

2 velocità / 2 speeds / 2 velocidades de /2 vitesses:	300 °C - 600 °C
Flusso d'aria / Air flow / Flujo de aire / Flux d'air:	500L/MIN - 650L/MIN
Potenza / Power / Alimentación / Puissance:	1,2 kW 230V 50HZ
Imballo / Packaging / Embalaje / Emballage:	10 KG



Art. 079/02

Cod. 05.008.01

€ 8,<sup>60</sup>

HOT!

Vassoio magnetico doppio  
Double magnetic part dish  
Bandeja magnética doble

(240x140 mm)



Cod. 05.064.00

€ 108,<sup>00</sup>



**Kit smontaggio/montaggio parabrezza**

Il kit include: 2 coppie di ventose oscillanti, 2 coppie di maniglie tirafilo, 1 attrezzo inseritore filo, 1 cinghia a cricchetto, 1 matassa di filo a sezione quadra.

**Kit for mounting and dismantling windcreens**

The kit includes: 2 couples of swivelling vacuum cups, 2 couples of wire gripping handles, wire feeder tool, 1 ratchet, steel square wire.

**Kit para montar y desmontar parabrisas**

El kit incluye: 2 pares de ventosas oscilantes, 2 pares de asas tirahilos, 1 herramienta para introducir el hilo, 1 correa con carraca, 1 madeja de hilo de sección cuadrada.

HOT!

Cod. 05.013.03

€ 9,<sup>00</sup>



**COPERTURA PARAFANGO MAGNETICA**

Protegge la carrozzeria da graffi e urti accidentali. In panno e neoprene. Dimensioni: 110x40cm

**WORKSHOP WING COVER WITH MAGNETS**

It protects the car wing from scratches and accidental damage. Cloth and neoprene. Dimensions: 110x40cm

**CUBIERTA GUARDABARROS MAGNÉTICA**

Protege el guardabarros de arañazos y daños accidentales. Paño y neopreno. Dimensiones: 110x40cm

Cod. 05.090.22

€ 18,<sup>00</sup>

HOT!

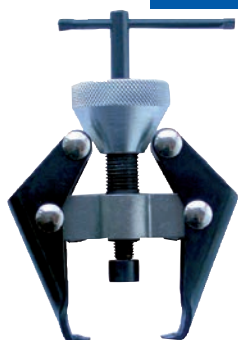

Estrattore per terminali batteria e bracci tergisristalli

Two Leg Puller for Battery Terminals and Widescreen Wipe Arms

Tirador a dos piernas para terminales de la batería y del limpiaparabrisa

Extracteur deux pieds pour les terminaux de la batterie et de l'essuie-glace

Art. 059\_12V

Cod. 04.042.00

€ 29,<sup>00</sup>



SOPPRESSORE DI IMPULSI

IMPULSE SUPPRESSOR

SUPRESOR DE IMPULSOS

Art. 059/01\_24V

Cod. 04.042.01

€ 29,<sup>00</sup>

Protegge gli impianti di iniezione e accensione elettronica da picchi di tensione durante i lavori di saldatura in carrozzeria: si monta tra + e - della batteria.

It protects electronic injection and ignition from voltage peaks during welding operations in workshops. It has to be installed between the + and - of the battery.

Protege la ignición y la inyección electrónica de picos de tensión durante las operaciones de soldadura en talleres. Tiene que ser instalado entre el + y - de la batería.

Cod. 05.062.04

€ 20,<sup>00</sup>

Set di 4pcs di pinze per micro saldatura

Set of 4pcs micro welding clamps

Juego de 4pcs abrazaderas para micro-soldadura



Cod. 05.062.03

€ 19,<sup>80</sup>



Pinza con testa orientabile per estrazione tappi in plastica

Clamp with adjustable head for extracting plastic caps

Abrazadera con cabeza ajustable para la extracción de tapones de plástico

Cod. 05.092.00

€ 22,00



**SET SMONTATUTTO**

6 utensili in plastica molto resistente, consentono di togliere tutti gli accessori smontabili dal veicolo senza graffiare le parti relative e la vernice.

**UNIVERSAL DEMOUNTING SET**

6 high-resistant plastic devices that enable you to remove all the demountable accessories from the vehicle without scratching the parts and the paint.

**JUEGO DE HERRAMIENTAS DE DESMONTAJE**

6 dispositivos de plástico de alta resistencia que le permiten eliminar todos los accesorios desmontables desde el vehículo sin rayar las partes y la pintura.



Cod. 05.092.01

€ 32,00



**SET 11 UTENSILI SMONTA-ACCESSORRI**

**KIT OF 11 TOOLS FOR DISASSEMBLING REMOVABLE ACCESSORIES**

**KIT DE 11 HERRAMIENTAS PARA DESMONTAR LOS ACCESORIOS REMOVIBLES**

**KIT DE 11 OUTILS DE DÉMONTAGE D'ACCESSOIRES DÉTACHABLES**

Cod. 05.087.10

€ 54,00



**Cavalletto appoggia cristalli**

**Saw-horse for windows**

**Caballete para apoda cristales**

Cod. 05.087.02

€ 190,00

**Cavalletto estensibile multiuso**  
**Extendible multi-purpose sawhorse**  
**Caballete extensible multiuso**



- Piani di lavoro rivestiti in gomma antisdrucciolo
- Regolazione in altezza (fino a 132cm)
- Regolabile in apertura (da 22,5 cm chiuso a 138cm completamente aperto)
- Portata 100kg
- 2 ruote con freno
- Ideale come supporto di appoggio per officine, carrozzerie, laboratori di assemblaggio in genere
- Nei momenti di non uso occupa uno spazio di 0,2m<sup>2</sup>
- Working surface covered with non slip rubber
- Adjustable height (up to 132cm)
- Adjustable opening (from 22,5 cm closed to 138cm completely open)
- Capacity 100kg
- 4 wheels with brake
- Ideal as a support for workshops, car body repairers' and assembling laboratories
- When closed it takes 0,2m<sup>2</sup>
- Tablero de trabajo con cobertura de caucho antideslizante
- Altura ajustable (hasta 132cm)
- Abertura ajustable (desde 22,5 cm cerrado hasta 138cm completamente abierto)
- Capacidad 100kg
- 4 ruedas con freno
- Ideal como soporte para talleres, chapistas, laboratorios de ensamblaje
- Cuando no se utiliza ocupa un espacio de 0,2m<sup>2</sup>

Cod. 05.084.06

€ 360,00



**CRICCO IDRAULICO A CARRELLO DA 2TON A GRANDE ALZATA**

**IDONEO PER LAVORI DI CARROZZERIA IN SPAZI PRIVI DI ALTRO TIPO DI SOLLEVATORI IDRAULICI**

**HAND HYDRAULIC JACK 2TONS GREAT ELEVATION**

**SUITABLE FOR BODY SHOP'S WORKS WHERE THERE IS NOT ANY OTHER KIND OF HYDRAULIC LIFTERS**

**GATO HIDRÁULICO DE MANO DE 2 TONELADAS CON ELEVACIÓN SUPERIOR**

**CONVENIENTE PARA LOS TRABAJOS EN TALLERES DE CHAPA Y PINTURA DONDE NO HAY CUALQUIER OTRO TIPO DE ELEVADOR HIDRAULICO**



Cod. 05.102.03

€ 170,00

Valigetta trolley con 186 utensili

Tool box with accessories 186 pcs

Valise portable avec 186 outils

Fahrbare Werkbank mit 186-tlg

Valija con 186 herramientas

**CHROME VANADIUM**



**CONTENTS: CONTENUTI:**

Utility knife 6" - Coltello 6"	1pz	Crimping pliers 8" - Pinza per crimpare 8"	1pz	1/4" Dr. Sockets - Teste 1/4"	
Claw hammer 120Z - Martello 120Z	1pz	Screwdrivers - Cacciaviti	14pz	4, 4.5, 5.5, 5, 6, 7, 8, 9, 10, 11, 12, 13mm	12pz
Measuring tape 5m - Nastro di misurazione 5m	1pz	(-) 3*75, 3*100, 4*100, 5*75, 6*38, 6*100, 6*125		1/2" Dr. Sockets - Teste	17pz
12" Level - Livella 12"	1pz	(+) 3*75, 3*100, 4*100, 5*75, 6*100, 8*150, 6*38mm		1/2" 10, 11, 12, 13, 14, 15, 16, 17, 18, 19, 20, 21, 22, 23, 24, 27, 30 mm	
Fasteners - Viti	60pz	Precision screwdrivers - Cacciaviti di precisione	6pz	Extension bars - Prolunghe	4pz
Nylon clamp - Morsetto di nylon	2pz	Y bit - Punta Y	1pz	Flexible extension bar - Prolunga flessibile	1pz
Pick-up tool - Strumento per afferrare	1pz	Bit holder - Porta punte	1pz	1/2" Dr. Spark plug sockets 16, 21mm	2pcs
Electric tape 10Y - Nastro elettrico 10Y	1pz	Bits in a plastic holder - Punta in supporto di plastica		Chiavi per candela 1/2" 16, 21 millimetri	2pz
Glue gun - Pistola per colla	1pz	(-) 3, 4, 5, 6, 7, (+) 0, 1, 2, 3, 4, PZ1, PZ2	12pz	Universal joint - Giunto universale	2pz
Long nose pliers 8" - Pinze lunghe 8"	1pz	Bits in a plastic holder - Punte in supporto di plastic		3-way adaptor - Adattatore a 3 vie	1pz
Diagonal pliers 7" - Pinze diagonali 7"	1pz	H3, 4, 5, 6, 7, 8, T10, 15, 20, 25, 30, 35	12pz	Hex-key - Chiavi esagonali	
Slip joint pliers 6" - Pinze regolabili 6"	1pz	Spinner handle - Gira bussola	1pz	1,5, 2, 2,5, 3, 4, 5, 6, 8, 10mm	9pz
Water pump pliers 10" - Pinza a pappagallo 10"	1pz	Ratchet screwdriver - Cacciavite a cricco	1pz	1/4 Dr. Ratchet Handle - Chiave a cricchetto 1/4	1pz
Lock pliers 7" - Pinza con blocco 7"	1pz	Electric tester - Tester elettrico 100V-250V	1pz	1/2 Dr. Ratchet Handle - Chiave a cricchetto 1/2	1pz
		Adjustable wrench 8" - Chiave regolabile 8"	1pz	Blow case - Valigetta paracolp	1pz
		Combination wrenches - Chiavi combinate	10pz	Aluminum box - Valigetta in alluminio	1pz
		6, 8, 10, 11, 12, 13, 14, 15, 17, 19mm			
		1/4" Dr. Sliding T-bar - Barra a T a scorrimento 1/4	1pz		



RISCALDATORI AD INDUZIONE SENZA FIAMMA  
FLAMELESS HEATING INDUCTORS  
INDUCTORES DE CALEFACCIÓN SIN LLAMA

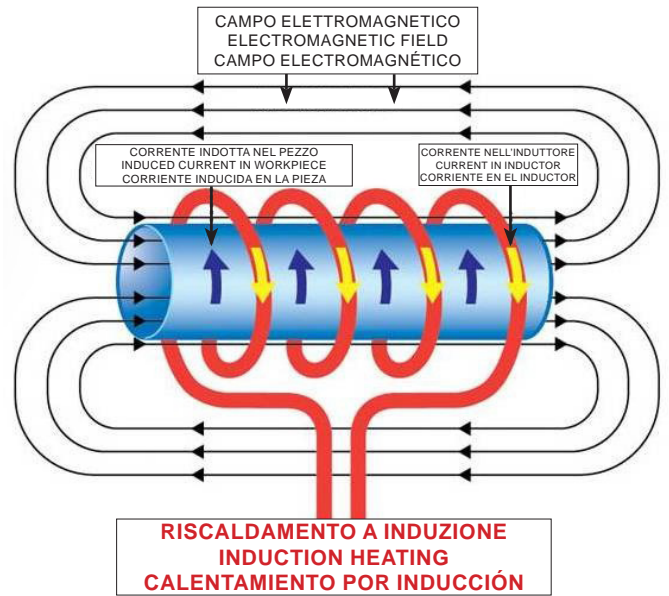

**CHE COS'È IL RISCALDAMENTO AD INDUZIONE?**

Il riscaldamento a induzione è un metodo veloce e pulito (in assenza di fiamme libere) per riscaldare metalli e altri materiali conduttivi. Un sistema di riscaldamento a induzione prevede un generatore di radiofrequenza che converte la corrente dalla rete elettrica in corrente alternata ad alta frequenza, e una testa di adattamento del carico che è in grado di generare un forte campo elettromagnetico all'interno dell'induttore.

**COME FUNZIONA UN INDUTTORE PER IL RISCALDO A INDUZIONE?**

Il componente da riscaldare viene posizionato all'interno o in prossimità dell'induttore, il campo genera una corrente all'interno del pezzo che si trasforma rapidamente in calore per effetto Joule. L'induttore è costituito da un tubo di rame, riscalda il componente senza alcun contatto: il calore è prodotto solo dalla corrente elettrica indotta nel materiale. Il pezzo da scaldare non deve toccare la spirale che deve lavorare solo sul particolare e non su piastre o pareti. Si possono raggiungere rapidamente (meno di 2 minuti) temperature di 600/700°C idonee a sbloccare bulloni di diametro fino a 40 mm. I materiali che è possibile riscaldare sono metallici come acciaio, rame, alluminio, ottone.

**WHAT IS INDUCTION HEATING?**

Induction heating is a fast and clean method (in absence of open flames) used to heat metals and other conductive materials. An induction heating system includes a radio frequency generator that converts the current from the power network in high frequency AC current, and a load adaptation head capable of generating a strong electromagnetic field within the inductor.

**HOW DOES AN INDUCTOR FOR THE INDUCTION HEATING WORK?**

The heating component is positioned inside or near the inductor, the field generates a current within the part that rapidly converts to heat thanks to the Joule effect. The inductor consists of a copper tube, it heats the component without any contact: heat is produced only by the induced electrical current in the material. The piece to be heated must not touch the spiral that has to work only on the component and not on the plates or walls. You can quickly reach (by less than 2 minutes) temperatures of 600/700 °C suitable for unlocking bolts up to 40 mm in diameter. You can heat metallic materials such as steel, copper, aluminum, brass.

**¿QUÉ ES EL CALENTAMIENTO POR INDUCCIÓN?**

Il riscaldamento a induzione è un metodo veloce e pulito (in assenza di fiamme libere) per riscaldare metalli e altri materiali conduttivi. Un sistema di riscaldamento a induzione prevede un generatore di radiofrequenza che converte la corrente dalla rete elettrica in corrente alternata ad alta frequenza, e una testa di adattamento del carico che è in grado di generare un forte campo elettromagnetico all'interno dell'induttore.

**¿CÓMO FUNCIONA UN INDUCTOR PARA LA CALEFACCIÓN POR INDUCCIÓN?**

El componente de calentamiento se coloca dentro o cerca del inductor, el campo genera una corriente dentro de la pieza que rápidamente se convierte en calor gracias al efecto Joule. El inductor consiste en un tubo de cobre, calienta el componente sin ningún contacto: el calor se produce únicamente por la corriente eléctrica inducida en el material. La pieza a calentar no debe tocar la espiral que tiene que funcionar solo sobre el componente y no sobre las placas o paredes. Puede alcanzar rápidamente (en menos de 2 minutos) temperaturas de 600/700 °C adecuadas para desbloquear pernos de hasta 40 mm de diámetro. Puede calentar materiales metálicos como acero, cobre, aluminio, latón.

APPLICAZIONI / APPLICATIONS / APLICACIONES



Smontaggio bulloni  
Disassembling bolts  
Desmontaje de pernos



Smontaggio marmitte  
Disassembling mufflers  
Desmontaje de silenciadores



Riscaldamento sonda Lambda  
Heating of Lambda Sensor  
Calentamiento del sensor Lambda

RISCALDATORI AD INDUZIONE SENZA FIAMMA  
 FLAMELESS HEATING INDUCTORS  
 INDUCTORES DE CALEFACCIÓN SIN LLAMA

Cod. 05.066.06

€ 780,00

INDUCTOR BASIC

Capacità: 1Kw;  
 Alimentazione: 230V 50 Hz  
 8 spirali incluse  
 Valigetta di trasporto in alluminio inclusa

Capacity: 1 Kw;  
 Power supply: 230V 50 Hz  
 8 spirals included  
 Aluminium transport case included

Capacidad: 1 Kw;  
 Alimentación: 230V 50 Hz  
 8 espirales incluidas  
 Maletín de transporte de aluminio incluido



ACCESSORI A RICHIESTA / ACCESSORIES ON REQUEST  
 ACCESORIOS BAJO PEDIDO

Cod. 05.066.06R2

€ 29,00

Bobina per riscaldamento superfici  
 Coil for heating surfaces  
 Bobina para calentar superficies



Cod. 05.066.07R2

€ 35,00

Nuova bobina piana per riscaldamento superfici  
 (metallo, alluminio, vetri auto)  
 New flat coil for heating surfaces (metal, aluminium,  
 car windows)  
 Nueva bobina plana para calefacción de superficies  
 (metal, aluminio, vidrios de automóviles)



Cod. 05.066.07

€ 1.040,00

INDUCTOR PROFÍ

Capacità: 1,2 Kw;  
 Alimentazione: 230V 50 Hz  
 8 spirali incluse  
 Valigetta di trasporto in alluminio inclusa

Capacity: 1,2 Kw;  
 Power supply: 230V 50 Hz  
 8 spirals included  
 Aluminium transport case included

Capacidad: 1,2 Kw;  
 Alimentación: 230V 50 Hz  
 8 espirales incluidas  
 Maletín de transporte de aluminio incluido



KIT RICAMBI / SPARE PARTS KIT / KIT RECAMBIOS

INDUCTOR BASIC KIT

Cod. 05.066.06R1

€ 128,00

INDUCTOR PROFÍ KIT

Cod. 05.066.07R1

€ 154,00







Cod. 05.090.49

€ 169,<sup>00</sup>

HOT!

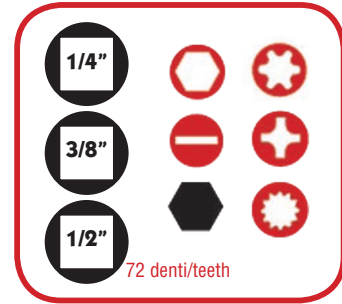

**CHROME VANADIUM**

**Chiavi a bussola 219 pz (1/2" - 3/8" - 1/4") + Chiavi combinate**     **219pcs 1/2" - 3/8" - 1/4" DR. socket wrench set + Combination spanner**



Cod. 05.090.17

€ 35,<sup>00</sup>

**CHROME VANADIUM**

**CASSETTA BUSSOLE 1/4" (46pz)**  
**46- piece Socket Set, 1/4"**

Bussole "super lock" da 4 a 13mm  
Inserti piani, croce, esagonali e torx  
Cricchetto reversibile a 45 denti  
Realizzato in conformità con le norme DIN  
T-Star kit bussole di diverse misure  
Materiale: cromo vanadio

Super lock sockets from 4 to 13mm  
Comes with plain slot, cross slot, hexagon and 45 tooth reversible ratchet with quick release button  
Made according to DIN standards  
T-Star prese bit di diverse dimensioni  
Matt chrome vanadium



Cod. 05.090.16

€ 110,<sup>00</sup>

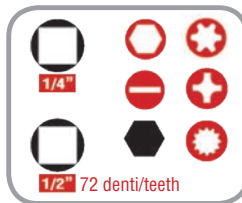

**Set bussole inserti da 1/4" e 1/2" (108pz)**  
**108-piece Socket Set, 1/4" e 1/2"**

**CHROME VANADIUM**

**6.3 (1/4) drive:**  
Ratchet, short extension, long extension, universal joint, sliding T-handle  
Super lock sockets in the following sizes: 4-4.5-5-5.5-6-7-8-9-10-11-12-13 and 14mm  
Super lock deep sockets in following sizes: 6-7-8-9-10-11-12-13mm  
T Star bit sockets: T8-T10-T15-T20-T25-T27-T30  
4x cross bit sockets and 3x slot bit sockets  
Hex bit sockets: 3-4-5-6mm  
E-type sockets: E4-E5-E6-E7-E8

**12.5 (1/2) drive:**  
Rauche, short extension, long extension, universal joint, sliding T-handle  
Super lock sockets in the following sizes: 10-11-12-13-14-15-16-17-18-19-20-21-22-24-27-30-32mm  
Super lock deep sockets in sizes: 14-15-17-19-22mm  
1x bit holder  
T Star bits: T40-T45-T50-T55-T60  
6 x cross bits and 3 slotted bits  
Hex bits: 7-8-9-10-12-14mm  
E-type sockets: E10-E11-E12-E14-E16-E18-E20-E24  
Spark plug sockets: 16 and 21mm



**CASSETTE BASE PER OGNI OFFICINA MECCANICA**

**BUSSOLE IN ACCIAIO AL CROMO-VANADIO TRATTATO E CROMATO FORNITE IN CASSETTA IN MATERIALE PLASTICO COMPOSITO**

**BASIC SETS FOR EVERY MECHANICAL WORKSHOP**

SOCKETS IN TREATED AND CHROMIUM-PLATED VANADIUM CHROMIUM IN A CASE OF COMPOSITE PLATIC MATERIALS

**SETS BASILAIRES POUR TOUS LES GARAGES MECHANQUES**

BOUSSOLES EN ACCIER AU CHROME -VANADIUM TRAITÉ ET CHROME FOURNIES EN COFFRET EN PLASTIQUE

**GRUNDAUSSTATTUNG FÜR JEDE MECHANIKER WERKSTATT**

CHROM-VANADIUM DOUBLIERTE UND VERCHROMTE STAHLBUCHSEN IN WERKZEUGKASTEN AUS KUNSTSTOFFVERBUNDMATERIALSETS

**BÁSICOS PARA TODOS LOS TALLERES MECÁNICOS**

CASQUILLOS EN ÁCERO AL CROMO VANADIO TRATADO Y CROMADO EN MALETÍN DE MATERIAL PLÁSTICO COMPUESTO

Cod. 05.089.00

€ 90,00

Cod. 05.090.00

€ 83,00

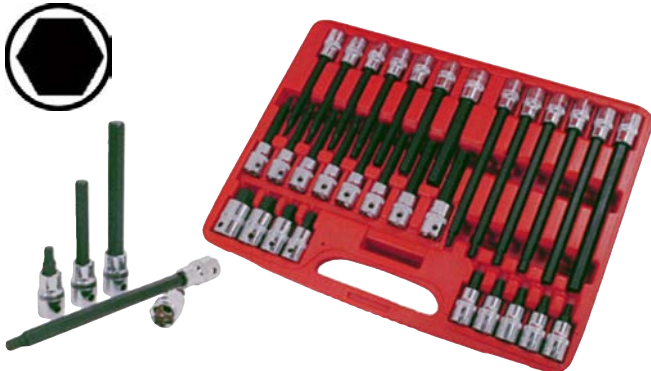

Set 30 pz chiavi bussola con esagono maschio attacco **1/2"**  
Set of 30 pcs exagonal male coupling wrenches

**Contenuto - It contains:** L 55 mm 5-6-7-8-10-12-14-17-19  
L 100 mm 5-6-7-8-10-11-12-13  
L 140 mm 5-6-8-10-12-14  
L 200 mm 5-6-7-8-10-12

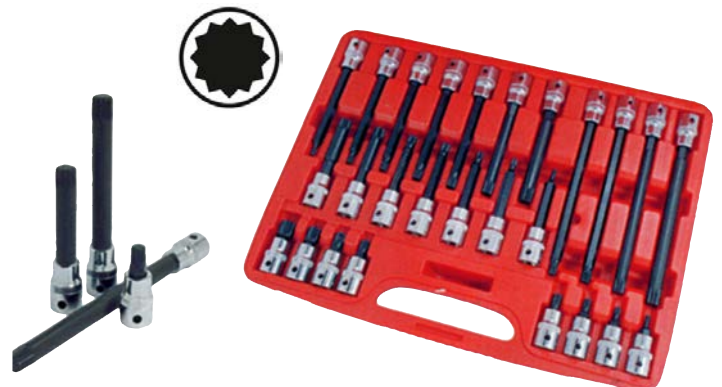

Set 26 bussole con inserto ZXN **1/2"**  
Set sockets with ZXN insert (26 pieces)

**Contenuto - It contains:** L 55 mm 5-6-7-8-9-10-12-14-16  
L 100 mm 5-6-8-9-10-12-14  
L 140 mm 5-6-8-9-10-12-14  
L 200 mm 8-10-12-14

Cod. 05.090.01

€ 93,90

Cod. 05.090.02

€ 93,90



Set 32pz bussole con inserto TX **1/2"**  
Set sockets with TX (32 pieces)

**Contenuto It contains:** L 55 mm T20-25-27-30-40-45-50-55-60-70  
L 100 mm T20-25-27-30-40-45-50-55-60-70  
L 140 mm T40-45-50-55-60-70  
L 200 mm T40-45-50-55-60-70



Set 32pz bussole con inserto RIBE **1/2"**  
Set sockets with RIBE (32 pieces)

**Contenuto It contains:** L 55 mm 5-6-7-8-9-10-12-13-14  
L 100 mm 5-6-7-8-9-10-12-13-14  
L 140 mm 8-9-10-12-13-14

Cod. 05.090.05

€ 110,00

**Set di 15 bussole per lo smontaggio**

Set of 15 sockets for the dismantling  
Set de 15 boussole pour le démontage  
Set 15 Buchsen zur Demontage  
Set de 15 casquillos para el desmontaje

10-11-12-13-14-15-17-19-21-24-27mm



Cod. 05.090.26

€ 49,<sup>50</sup>



**Kit 14 chiavi a pipa**  
14 double ended offset hexagon wrenches kit  
Juego de 14 llaves extensibles hexagonales

Cod. 05.090.29B

€ 115,<sup>00</sup>

CON TERMOFORMATO / WITH THERMOFORMED BASE / CON BASE TERMOFORMADA

Cod. 05.090.29

€ 113,<sup>00</sup>

SENZA TERMOFORMATO / WITHOUT THERMOFORMED BASE / SIN BASE TERMOFORMADA



**Kit 7 chiavi a T  
snodate**

**7 T-bended  
wrenches kit**

**Juego de llaves  
de cubo a "T"**

(7, 8, 10, 11,  
13, 15, 17mm)



Cod. 05.090.48

€ 38,<sup>00</sup>

**CRICCHETTO 1/2" ESTENSIBILE**  
1/2" EXTENDIBLE RATCHET



Cod. 05.090.15

€ 59,<sup>80</sup>

**Set di 25 chiavi combinate  
6-32mm**

In acciaio al cromo-vanadio  
6-7-8-9-10-11-12-13  
14-15-16-17-18-19-20-21  
22-23-24-25-26-27-28-30-32mm  
Custodia in tetron  
conforme a norma din 3113 A

**25-piece Combination  
Spanner Set, 6-32mm**

All parts manufactured from chrom  
vanadium-steel;  
Hardened, chrome plated  
6-7-8-9-10-11-12-13  
14-15-16-17-18-19-20-21  
22-23-24-25-26-27-28-30-32mm  
Packed in a tetron wallet  
According to DIN 3113 A

**CHROME VANADIUM**



**HOT!**



Cod. 05.090.14

€ 28,<sup>00</sup>

**Set 12 cacciaviti  
con esagono esterno  
per una maggior coppia  
usando una chiave a bussola**

**Screwdriver kit, 12pcs,  
end-to-end hex blade  
with outer hexagon for extra torque using  
a spanner or socket**





Cod. 05.078.04

€ 66,00

**SET CHIAVI COMBinate PER ALTERNATORI  
(22Pcs)**

**KIT OF COMBINED WRENCHES FOR ALTERNATORS  
(22Pcs)**

APPLICAZIONI / APPLICATION:

ALTERNATORI - ALTERNATORS  
BOSCH - DENSO

MARCHI/ BRANDS:

VW - AUDI - MERCEDES BENZ - RENAULT - PEUGEOT  
CITROEN - BMW - OPEL - FORD - FIAT - HONDA - PORSCHE

Diffusi dettagli a richiesta  
More details on request



Cod. 05.090.23

€ 31,00

**ALLARGAFORI A GRADINI 3 Pz  
STEPPED HOLE ENLARGER 3 Pcs  
AGRANDISSEUR DE TROUS À GRADINS  
ENLARGADORA DE AGUJEROS ESCALONADA**

- ❑ Ideal for drilling thin metal sheets without distorting
- ❑ For all types of metal, industrial plastic and sheet metal up to 3 mm thick
- ❑ Content: 1x4-12mm, 1x4-20mm, 1x4-32mm
- ❑ Wooden case

- ❑ Ideal para la perforación de chapas sin deformarlas
- ❑ Para todo tipo de metal, plástico industrial y chapas de hasta 3 mm de espesor
- ❑ Contenido: 1x4-12mm, 1x4-20mm, 1x4-32mm
- ❑ Caja de madera

- ❑ Idéal pour le forage de feuilles métalliques minces sans les déformer
- ❑ Pour tous types de métaux, plastiques industriels et tôles jusqu'à 3 mm d'épaisseur
- ❑ Contenu: 1x4-12mm, 1x4-20mm, 1x4-32mm
- ❑ Caisse en bois



Cod. 05.090.52

€ 122,00

**Set 13 chiavi combinate a cricchetto 8÷32mm**

**13 combination spanner ratchets set 8÷32mm**

**Set de 13 cliquets de serrage combinées 8÷32mm**

**Juego de 13 llaves combinadas 8÷32 mm**

**CHROME VANADIUM**



# VIDEOSCOPIO *Evolution*



Cod. 03.029.14

€ 750,00

Ø 5,5mm L=1000

Cod. 03.029.33

€ 990,00

Ø 4mm L=1000



## Nuove prestazioni

- ❑ Sonda semirigida, resistente ad oli e abrasioni
- ❑ 4 led con illuminazione potenziata
- ❑ Maggiore velocità di ripresa in video e foto
- ❑ Memory card potenziata (fino 25.000 foto o video)
- ❑ Menu in 6 lingue (Italiano, English, Deutsch, Français, Español, Portugues)
- ❑ Migliore qualità dei colori e risoluzione

## CARATTERISTICHE TECNICHE

- ✓ Ø 5,5mm di diametro
- ✓ Risoluzione dinamica 320x240 pixel
- ✓ 4 LED ad alta efficienza
- ✓ Video da 3.5" in vetro temperato resistente ad oli e abrasioni
- ✓ Lunghezza cavo flessibile= 1000/2000/3000mm
- ✓ Memorizza foto e video che può scaricare su pc o su video tv tramite porta USB.
- ✓ Memoria SD fino a 2 GB
- ✓ Specchio 90°/70°/110°
- ✓ Immagazzinamento immagini in formato jpeg
- ✓ 4 tasti per scorrimento menù
- ✓ Pacco batterie (al litio) ricaricabili
- ✓ Applicazioni: motori benzina e diesel auto e industriali, marini, aviazione, impianti a/c, lamierati, macchinari industriali in genere.
- ✓ Dimensioni: 200x117x37;
- ✓ Peso: 0,7 Kg

## New performances

- ❑ Semirigid probe, oil-proof and abrasion resisting
- ❑ 4 leds with powered light
- ❑ Faster video recording and picture taking
- ❑ Powered memory card (up to 25.000 pictures or videos)
- ❑ Menu in 6 languages (Italiano, English, Deutsch, Français, Español, Portugues)
- ❑ Better quality of the colours and resolution

## TECHNICAL FEATURES

- ✓ Diameter: Ø 5,5mm
- ✓ Dynamic Resolution 320x240 pixel
- ✓ 4 high-efficiency LED
- ✓ 3.5" screen in oil-proof and abrasion resisting tempered glass resistant
- ✓ Flexible hose length= 1000/2000/3000mm
- ✓ It stores pictures and video, which can be also downloaded to the pc or TV screen through USB port.
- ✓ SD memory card up to 2GB
- ✓ 90°/70°/110°Mirrors
- ✓ It stores jpeg pictures
- ✓ 4 keys to scroll the menu
- ✓ Rechargeable (lithium) battery pack
- ✓ Applications: gasoline and diesel engines of cars and industrial vehicles, boats, aviation, a/c systems, plates, industrial machineries.
- ✓ Dimensions: 200x117x37;
- ✓ Weight: 0,7 Kg

## Nouvelles performances:

- ❑ Sonde semi-rigide, résistante à huile et abrasions
- ❑ 4 led avec illumination de majeure intensité
- ❑ Majeure vitesse d'enregistrement de vidéos et photos
- ❑ Memory card de majeure capacité (jusqu'à 25.000 photos ou vidéos)
- ❑ Menu en 6 langues (Italiano, English, Deutsch, Français, Español, Portugues)
- ❑ Meilleure qualité des couleurs et de résolution

## CARACTÉRISTIQUES TECHNIQUES

- ✓ Diamètre: Ø 5,5mm
- ✓ Résolution dynamique 320x240 pixel
- ✓ 4 LED à haute efficacité
- ✓ Ecran de 3.5" en verre tempéré résistant aux huiles et aux abrasions
- ✓ Longueur du câble flexible= 1000/2000/3000mm
- ✓ Mémorisation de photos et images qu'on peut transférer sur PC ou sur vidéo TV avec porte USB.
- ✓ Mémoire SD jusqu'à 2GB
- ✓ Miroir à 90°/70°/110°
- ✓ Mémorisation des images en format jpeg
- ✓ 4 touches pour avancer le menu
- ✓ Paquet batteries (au lithium) rechargeables
- ✓ Applications: moteurs essence et diesel de voitures et camions, moteurs marins, aviation, et systems A/C, machines industrielles en général.
- ✓ Dimensions: 207x117x37;
- ✓ Poids: 0,7kg

**Neue Leistungen**

- ☐ Halbsteifer Fühler, resistent gegen Öle und Abnutzungen
- ☐ 4 led mit mehr Beleuchtung
- ☐ Mehr Aufnahmeschnelligkeit von Video und Photos
- ☐ Gesteigerte Memory card (bis zu 25.000 Photos oder Video)
- ☐ Fühler mit Kleinbildkamera von 90° (auf Wunsch)
- ☐ Menu in 6 Sprachen (*Italiano, English, Deutsch, Francais, Español, Portugues*)
- ☐ Mehr Qualität von den Farben und der Auflösung

**ALLGEMEINE DATEN**

- ✓ Durchmesser: Ø 5,5mm
- ✓ Dynamische Auflösung: 320x240 Pixels
- ✓ 4 Hochleistungsfähigkeit LED
- ✓ Schirm von 3.5" aus Sekuritglas und resistent gegen Öle und Abnutzungen
- ✓ Flexibles Kabe: Länge=1000/2000/3000mml
- ✓ Es merkt Photos und Video, die es am PC oder am Videoschirm durch USB Halter übertragen kann.
- ✓ Steuerung SD bis zu 2 GB
- ✓ 90°/70°/110° Spiegel
- ✓ Speicherung Bilder mit Format jpeg
- ✓ 4 Tasten für den Gleiten von das Menu
- ✓ Paket von ladbare Batterien (aus Lithium)
- ✓ Anwendungen: Benzin /Dieselmotor Autos und industrielle, maritime, Luftfahrt, Klimaanlage aus Blech, industrielle Maschinen im Allgemeinen.
- ✓ Abmessungen: 207x117x37;
- ✓ Gewicht: 0,7 Kg

**Nuevas prestaciones**

- ☐ Sonda semirígida, resistente a los aceites y al desgaste por rozamiento
- ☐ 4 led con iluminación potenciada
- ☐ Mayor rapidez para grabar video y sacar fotografías
- ☐ Memory card potenciada (hasta 25.000 fotografías o videos)
- ☐ Menu en 6 idiomas (*Italiano, English, Deutsch, Francais, Español, Portugues*)
- ☐ Calidad de los colores y resolución más elevadas

**DATOS TÉCNICOS**

- ✓ Diámetro: Ø 5,5mm
- ✓ Resolución dinámica: 320x240 píxeles
- ✓ 4 LED de eficiencia elevada
- ✓ Pantalla de 3.5" de vidrio templado resistente a los aceites y al desgaste por rozamiento
- ✓ Longitud del cable flexible=1000/2000/3000mm
- ✓ Memoriza fotografías y vídeos, que se pueden descargar en el PC o en la pantalla TV a través del puerto USB.
- ✓ Memoria SD hasta 2GB
- ✓ Espejo 90°/70°/110°
- ✓ Memoriza imágenes en jpeg
- ✓ 4 teclas para deslizamiento menu
- ✓ Paquete de batería (litio) recargables
- ✓ Aplicaciones: motores de gasolina y diesel de coches y vehículos industriales, barcos, aviación, instalaciones a/c, planchas, maquinarias industriales.
- ✓ Dimensiones: 207x117x37;
- ✓ Peso: 0,7 Kg

1	Porta USB / USB port
2	Regolazione illuminazione Light adjustment
3	Video TFT LCD 3,5" 3,5" TFT LCD screen
4	Tasti men / Menu keys
5	Tasto per foto / Snap shot
6	Tasto per video / Video recording key
7	ON/OFF
8	Vano SD card /SD card slot
9	Porta AV / AV port
10	Presca AC / AC jack
11	Valigetta per il trasporto / Transport case

**Corredo standard / Standard equipment**

- |          |                                    |          |                                |
|----------|------------------------------------|----------|--------------------------------|
| <b>A</b> | Cavo AV / AV cable (2mt)           | <b>D</b> | Specchio / Mirror 70° 90° 110° |
| <b>B</b> | Cavo USB / USB cable (USB 1.1/2.0) | <b>E</b> | SD card (1GB)                  |
| <b>C</b> | Caricabatteria / Battery charger   |          |                                |

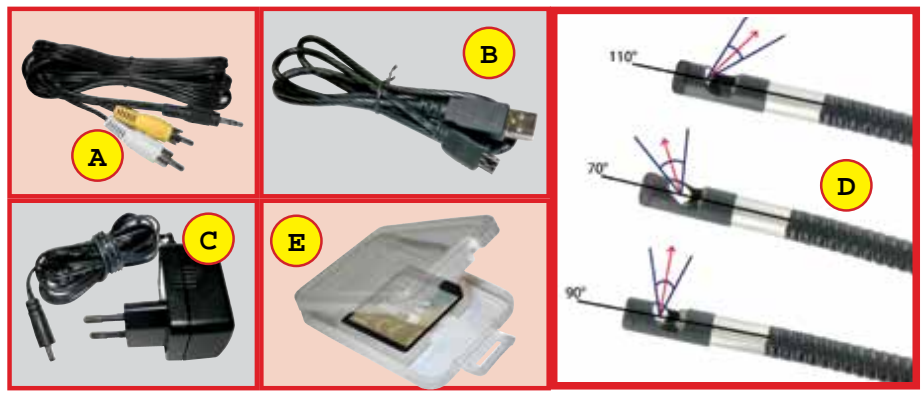

Cod. 03.029.39

€ 990,00



**VIDEOSCOPIO CON DOPPIA VIDEOCAMERA  
E SONDA DA 5,8 MM**

**DOUBLE CAMERA AND 5.8 MM  
PROBE VIDEOSCOPE**

**VIDÉOSCOPE AVEC SONDE DE 5,8 MM  
ET DOUBLE CAMÉRA**

**DOPPELKAMERA-VIDEOSKOP  
MIT DEM SONDENKOPF 5,8 MM**

**VIDEOSCOPIO DE DOBLE VIDEOCÁMARA  
Y SONDA DE 5,8 MM**

- |   |  |   |   |  |
|---|--|---|---|--|
| ✓ Schermo 3,5" TFT                                  | ✓ 3,5" TFT display                                 | ✓ Affichage 3,5" TFT                            | ✓ Displaz 3,5" TFT                              | ✓ Pantalla de 3,5" TFT                         |
| ✓ Selettore camera a 0° ed a 90° sulla sonda stessa | ✓ Camera selector at 0° and at 90° on the probe    | ✓ Caméra sélecteur à 0° et à 90° sur la sonde   | ✓ Kameraumschalter bei 0° und 90° auf der Sonde | ✓ Selector cámara de 0° y de 90° en la sonda   |
| ✓ Risoluzione 640X480 pixel                         | ✓ Resolution 640X480 pixel                         | ✓ Résolution de 640X480 pixels                  | ✓ Auflösung 640X480 pixels                      | ✓ Resolución 640X480 pixel                     |
| ✓ Funzione : foto (jpeg), video, rotazione, zoom    | ✓ Function: snapshot (jpeg), video, rotation, zoom | ✓ Fonction: image (jpeg), vidéo, rotation, zoom | ✓ Funktion : Foto (Jpeg), Video, Drehung, Zoom  | ✓ Función : foto (jpeg), vídeo, rotación, zoom |
| ✓ Software multilingue                              | ✓ Multilingual software                            | ✓ Logiciel multilingue                          | ✓ Mehrsprachige Software                        | ✓ Software multilingüe                         |
| ✓ Batterie AC litio                                 | ✓ Lithium AC batteries                             | ✓ Batteries AC au lithium                       | ✓ Baterias AC de litio                          | ✓ Lithium-Batterie AC                          |
| ✓ Cavo video incluso                                | ✓ Video cable included                             | ✓ Câble vidéo inclus                            | ✓ Vedeo-Kabel inbegriffen                       | ✓ Cable de vídeo incluido                      |
| ✓ Scheda SD 4 GB inclusa                            | ✓ 4 GB SD card included                            | ✓ Carte SD 4 GB inclus                          | ✓ SD-Speicherkarte, 4GB, inbegriffen            | ✓ Tarjeta SD de 4 GB incluida                  |

**ACCESSORI A RICHIESTA - ACCESSORIES ON REQUEST - ACCESORIOS BAJO PEDIDO - ACCESSOIRES SUR DEMANDE - ZUBEHÖR AUF ANFRAGE**

**Cod. 03.029.30**

Prezzo a richiesta  
Price on request  
Precio bajo pedido



Sonda 1 mt Ø 5,5 MM Per videoscopi serie 03.029.14  
Probe 1 mt Ø 5.5 MM For videoscopes 03.029.14  
Sonde de 1 mt Ø 5,5 MM Pour vidéoscopes 03.029.14  
Sonde 1 mt Ø 5,5 MM Für Videoskope 03.029.14  
Sonda de 1 mt Ø 5,5 MM Para videoscópios 03.029.14

**Cod. 03.029.37**

Prezzo a richiesta  
Price on request  
Precio bajo pedido



Sonda articolata 1 mt Ø 5,5 MM Per videoscopi serie 03.029.14  
Articulating head probe 1 mt Ø 5.5 MM For videoscopes 03.029.14  
Sonde avec tête de la sonde articulée de 1 mt Ø 5,5 MM Pour vidéoscopes 03.029.14  
Bewegliche Sonde 1 mt Ø 5,5 MM Für Videoskope 03.029.14  
Sonda con cabeza articulada de 1 mt Ø 5,5 MM Para videoscópios 03.029.14

**Cod. 03.029.40**

Prezzo a richiesta  
Price on request  
Precio bajo pedido



Sonda con doppia videocamera Ø 5,8 MM  
Per videoscopi serie 03.029.14  
Double-camera probe Ø 5.8 MM  
For videoscopes 03.029.14  
Sonde double caméra Ø 5,8 MM  
Pour vidéoscopes 03.029.14  
Sonde mit Doppelkamera Ø 5,8 MM  
Für Videoskope 03.029.14  
Sonda de doble cámara Ø 5,8 MM  
Para videoscópios 03.029.14

**Cod. 03.029.41**

Prezzo a richiesta  
Price on request  
Precio bajo pedido



Sonda 20 mt Ø 28 MM con lente e raccoglitore  
Per ispezioni settore idraulica e termotecnica  
Per videoscopi serie 03.029.14  
Probe 20 mt Ø 28 MM with magnifying glass and cable collector Suitable for plumbers and heater technical inspections  
For videoscopes 03.029.14  
Sonde 20 mt Ø 28 MM mit der Linse und Kabelsammler Zum Einsatz im thermohydraulischen Bereich. Für Videoskope Serie 03.029.14  
Sonde de 20 mt Ø 28 MM avec loupe et bobine de câble Utilisable pour plombiers et inspection des chaudières. Pour vidéoscopes 03.029.14  
Sonda de 20 mt Ø 28 MM con lupa y recogecables Utilizable para inspecciones de plomeros y caldereros. Para videoscópios 03.029.14



Cod. 03.029.22

€ 1.450,00



Videoscopio con testasonda articolata

Videoscope with articulated head probe

Vidéo scope avec tête de la sonde articulée

Videoskop mit beweglichem Sondenkopf

Videoscopio con sonda de cabeza articulada

**Caratteristiche tecniche:**

- ✓ Ø 5,5mm;
- ✓ L = 1000
- ✓ Video TFT 3,5"
- ✓ Risoluzione: 240x360dpi
- ✓ Sonda rotante 360° (fig. C)
- ✓ Testina rotante ± 180° (fig. B)

**Technical features:**

- ✓ Ø 5,5mm;
- ✓ L = 1000
- ✓ Video TFT 3,5"
- ✓ Resolution: 240x360dpi
- ✓ 360° rotating probe (picture C)
- ✓ Rotating probe ± 180° (picture B)

**Caractéristiques techniques:**

- ✓ Ø 5,5mm;
- ✓ L = 1000
- ✓ Vidéo TFT 3,5"
- ✓ Résolution: 240x360dpi
- ✓ Sonde pivotante 360° (fig. C)
- ✓ Tête pivotante ± 180° (fig. B)

**Technische Daten:**

- ✓ Ø 5,5mm;
- ✓ L = 1000
- ✓ Video TFT 3,5"
- ✓ Auflösung: 240x360dpi
- ✓ Sondendrehung 360° (Bild C)
- ✓ Sondenkopfdrehung ± 180° (Bild B)

**Características técnicas:**

- ✓ Ø 5,5mm;
- ✓ L = 1000
- ✓ Video TFT 3,5"
- ✓ Resolución: 240x360dpi
- ✓ Sonda giratoria de 360° (fig. C)
- ✓ Cabeza giratoria ± 180° (fig. B)

**Dotazione standard:**

videoscopio  
caricabatteria  
cavo TV  
cavo USB  
SD card (1GB)  
3 specchi (70°, 90°, 110°)  
1 magnete  
valigetta per il trasporto

**Standard equipment:**

videoscope  
battery charger  
TV cable  
USB cable  
SD card (1GB)  
3 mirrors (70°, 90°, 110°)  
1 magnet  
transport case

**Equipment standard:**

vidéo scope  
chargeur batteries  
câble TV  
câble USB  
carte SD (1GB)  
3 miroirs (70°, 90°, 110°)  
1 calamite  
Coffret de transport

**Standard Ausstattung:**

Videoskop  
Ladegerät  
TV Kabel  
USB Kabel  
SD-Speicherkarte (1GB)  
3 Spiegel (70°, 90°, 110°)  
1 Magnet  
Koffer

**Equipo estándar:**

videoscopio  
recargabaterias  
cable TV  
cable USB  
SD card (1GB)  
3 espejos (70°, 90°, 110°)  
1 magneto  
maletín para el transporte



MT 7

Cod. 02.017.00

€1.440,00

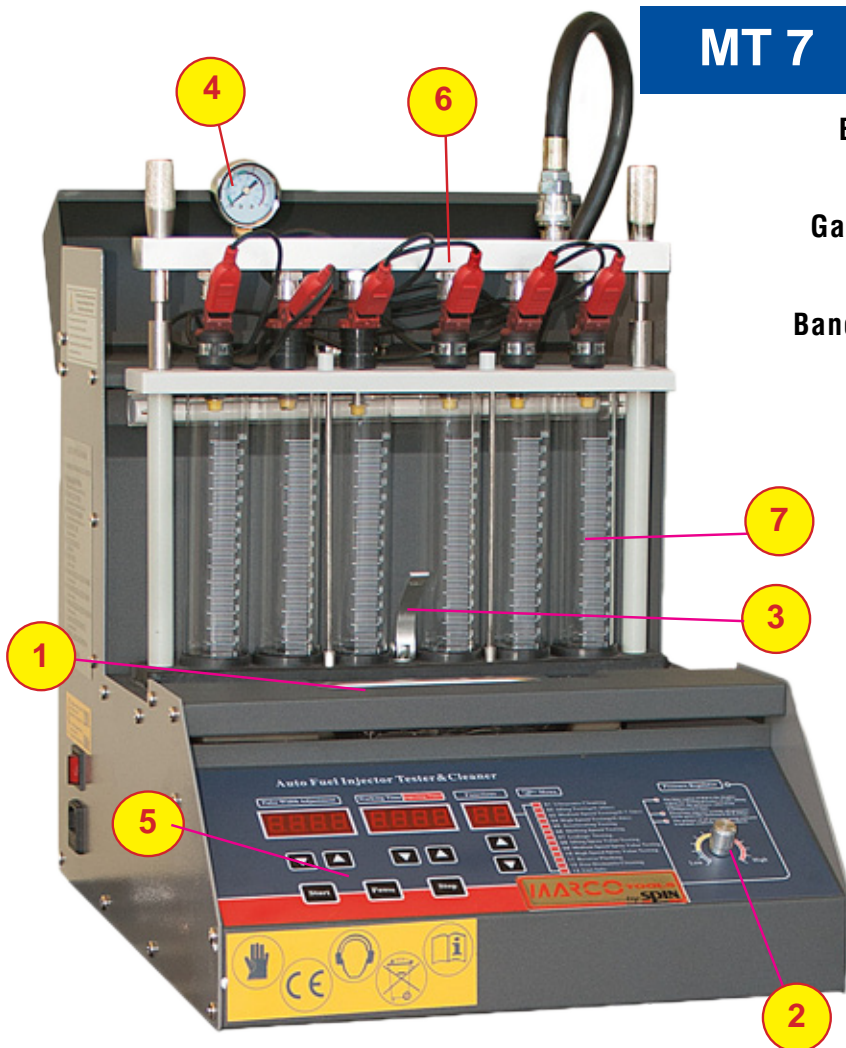

**Banco Prova iniettori benzina con vasca ad ultrasuoni incorporata (6 iniettori)**

**Gasoline injector test bench with ultra-sound tank integrated (6 injectors)**

**Banc essai injecteurs essence avec machine à ultrasons incorporée (6 injecteurs)**

**Prüfstand für Benzin-Einspritzventile mit integriertem Ultraschall Becken (6 Einspritzventile)**

**Banco Prueba para inyectores de gasolina con cuba de ultrasonidos integrada (6 inyectores)**



Possibilità di provare iniettori Mono e Multipoint (TBI/MPFI) e metano

It can test the following types of injectors:  
Mono and Multipoint (TBI/MPFI) and methane

Möglichkeit zu prüfen Mono- und Multipointinjektoren  
(TBI/MPFI) und Methan

Possibilité de tester injecteurs  
Mono et Multipoint (TBI/MPFI) et méthane

Posibilidad de probar inyectores  
Mono y Multipoint (TBI/MPFI) y metano

- |  |  |   |  |   |
|--|--|---|--|---|
| 1. Vasca ultrasuoni                                | 1. Ultrasonic tank   | 1. Bac à ultrasons  | 1. Ultraschallwaschtank                                  | 1. Cuba de ultrasonidos   |
| 2. Regolatore elettrico pressione di prova         | 2. Electric regulator of test pressure                             | 2. Régulateur électrique de la pression d'essai           | 2. Elektrischer Regler Probe Druck                       | 2. Regulador eléctrico de la presión de prueba                                    |
| 3. Leva scarico simultaneo burette                 | 3. Lever for simulta neous discharge of the burettes               | 3. Levier déchargement simultanés des burettes            | 3. Hebel gleichzeitige Ablass Bürette                    | 3. Palanca de descarga simultánea de lasburetas                                   |
| 4. Manometro pressione rail                        | 4. Rail pressure gauge   | 4. Manomètre pression du rail                             | 4. Druck Rail Manometer                                  | 4. Manómetro presión rail   |
| 5. Tastiera selezione programmi automaticie liberi | 5. Keypad for selection of programs (automatic and of your choice) | 5. Clavier sélection des programs automati ques et libres | 5. Tastatur für automatische und freie Programme Auswahl | 5. Teclado para la selección de los programas (automáticos y de vuestra elección) |
| 6. Rail standard (Top feed)                        | 6. Rail standard (top feed)  | 6. Rail standard (Top feed)                               | 6. Standard Rail (top feed)                              | 6. Rail estándar (Top feed)   |
| 7. Burette di prova con illuminazione a led        | 7. Test burettes with led light                                    | 7. Burettes d'essai avec illumination à leds              | 7. Test Bürette mit Led Beleuchtung                      | 7. Buretas de prueba iluminadas con led   |

**Incluso basamento  
Base included  
Base incluida  
Base comprise  
Unterwagen inbegriffen**



**Corredo Base MT7  
Basic equipment for MT7  
Equipos básicos para MT7  
Kit de base pour MT7  
(A)**



035 Cod. 04.031.00

€ 470,00

**PISTOLA STROBOSCOPICA DIGITALE a 4 funzioni**

**MULTIFUNCTIONS DIGITAL STROBO GUN FOR FUEL ENGINE**

**LAMPE STROBOSCOPIQUE DIGITALE POUR MOTEUR A ESSENCE**

**DIGITALE MULTIFUNKTIONS-STROBOSKOPPISTOLE FÜR VERBRENNUNGSMOTORE**

**PISTOLA ESTROBOSCÒPICA DIGITAL con 4 funciones (gasolina)**

- R.P.M. (9999 r.p.m.)
- Dwell (%)
- Anticipo (°)
- Volt (99,9 V)
- Dati tecnici vetture
- Valigetta di trasporto

- R.P.M. (9999 r.p.m.)
- Dwell (%)
- Advance (°)
- Volt DC (99,9 V)
- Case and hand book

- Tours moteur jusqu'à 10.000
- Dwell (%)
- Avance (0÷99,9°)
- Volt (99,9 V)
- Données technique voiture
- Mallette en ABS

- Drehzahl: 9999
- Dwell (%)
- Vorleistung (°)
- Volt DC (99,9 V)
- Technische Daten des Fahrzeuges
- ABS-Koffer t/min

- R.P.M. (9999 r.p.m.)
- Dwell (%)
- Avance (°)
- Voltios (99,9 V)
- Datos técnicos vehiculos
- Maletin in ABS



**\*ALTRI MODELLI IMPORTATI DISPONIBILI A RICHIESTA - OTHER IMPORTED ITEMS AVAILABLES ON DEMAND**

035.1 Cod. 04.034.00

€ 365,00



per rilievo giri e anticipo di impianti di iniezione diesel. Sensore piezoelettrico Ø6mm incluso. Altre misure a richiesta.

to test rpm and advance of diesel injection systems. Piezoelectric sensor Ø6mm included, it is possible to have other diameters on request.

pour le relèvement des tours et avance des systèmes d'injection diesel. Senseur piézo-électrique Ø6mm inclus. Autres mesures sur demande.

für Drehzahltest und Versteller von Dieseleinspritzanlagen. Piezoelektrischer Sensor Ø6mm inbegriffen. Sonstige Abmessungen auf Anfrage.

para testar las revoluciones y el avance de las instalaciones de inyección diesel. Sensor piezoeléctrico Ø6mm incluido, otros tananós disponibles bajo pedido.



**ADATTATORE DIESEL UNIVERSALE (12DC)**

**Universal diesel adapter (12DC)**

**Adaptateur diesel universel (12DC)**

**Universal Diesel Adapter (12DC)**

**Adaptador universal diesel (12DC)**

035/95 Cod. 04.033.00

€ 890,00



**PISTOLA STROBOSCOPICA BENZINA E DIESEL**

**TIMING LIGHT FOR PETROL AND DIESEL ENGINES**

**LAMPE STROBOSCOPIQUE ESSENCE ET DIESEL**

**STROBOSKOPPISTOLE BENZIN UND DIESEL**

**PISTOLA ESTROBOSCÒPICA GASOLINA Y DIESEL**

5 Funzioni Benzina  
2 Funzioni DIESEL:

- RPM (300 + 9.990 RPM)
- DWELL (20 ÷ 99,9°)
- VOLT (0,1 - 60 V)
- VOLT PICCO (0,1 - 60 V)
- ANTICIPO (0,1÷99,9°)
- RPM DIESEL
- ANTIC. DIESEL

5 Functions petrol  
2 functions for diesel:

- RPM (300 + 9.990 RPM)
- DWELL (20 ÷ 99,9°)
- VOLT (0,1 - 60 V)
- VOLT PEAK (0,1 - 60 V)
- AVANCE (0,1÷99,9°)
- RPM DIESEL
- AVANCE DIESEL

5 Fonctions Essence  
2 Fonctions DIESEL:

- RPM (300 + 9.990 RPM)
- DWELL (20 ÷ 99,9°)
- VOLT (0,1 - 60 V)
- VOLT DE PIQUE (0,1 - 60 V)
- AVANCE (0,1÷99,9°)
- RPM DIESEL
- AVANCE DIESEL

5 Funktionen Benzin  
2 Funktionen DIESEL:

- RPM (300 + 9.990 RPM)
- DWELL (20 ÷ 99,9°)
- VOLT (0,1 - 60 V)
- VOLT SPITZE (0,1 - 60 V)
- VERSTELLER (0,1÷99,9°)
- RPM DIESEL
- VERST. DIESEL

5 funciones gasolina  
2 funciones Diesel:

- GPM (300+9.990 GPM)
- Dwell (20÷99,9°)
- Voltios (0,1 - 60V)
- Voltios Pico (0,1 - 60 v)
- Avance (0,1 99,9°)
- GPM Diesel
- Avance Diesel





**CARATTERISTICHE TECNICHE:**

Misuratore del livello sonoro di classe 1  
Le normative rispettate dal prodotto: IEC61672, ISO-9001, CE, IEC1010  
Diametro esterno microfono standard 0.5"  
Costanti di tempo Slow e Fast  
Funzionamento facile ed innovativo, per la configurazione del software non è necessario il computer, il fonometro è dotato di serie di una memory card SD per il registro dei dati (anno /mese /giorno /ora /minuti /secondi) che si introduce nel lettore del computer per la lettura in formato Excel, l'utente può effettuare le ulteriori analisi grafici.

**TECHNICAL FEATURES**

Frequency and time weighting Class 1  
weighting networks comply with standards IEC61672, ISO-9001, CE, IEC1010

0.5" standard microphone head  
Memory function to store the Max. & Min. value  
Hold and Peak Hold functions

Innovation and easy operation, computer is not need to setup extra software, after execute data logger, just take away the SD card from the meter and plug in the SD card into the computer, it can download all the measured values with the time information (year/month/date/hour/minute/second) to the Excel directly, then user can make the further data or graphic analysis by themselves

- Measurement range: 30 - 130 dB
- Resolution: 0.1 dB
- Function: dB (A & C frequency weighting Time weighting (Fast,Slow), Peak hold, Data hold, Record (Max., Min.)
- Calibration VR: Build in external calibration VR, easy to calibrate on 94 dB level by screw driver. Calibrated via external SOUND CALIBRATOR (optional)
- Weight: 489 g/1,08 LB
- Dimension: 245 x 68 x 45 mm
- Accessories Included: instruction manual, hard carrying case, CA-06
- Optional accessories: Sound wind shield ball sound calibrator (94 dB)  
SD Card (2GB)  
USB cable, USB-01  
Data acquisition software, SW-U801-WIN.

Cod. 04.019.02

€ 579,00

**FONOMETRO DIGITALE CLASSE 1  
con SD card e uscita USB**

**DIGITAL SOUND LEVEL METER  
SD Card real time data logger**

**SONÓMETRO DIGITAL**

**Tarjeta SD registradora de datos en tiempo real**

- Campo di misura: 30 - 130 dB
- Risoluzione: 0.1 dB
- Funzioni: dB (ponderazione A e C, costanti di tempo Fast e Slow, Hold Peak, Data Hold, Record (max, min))
- Taratura VR: taratura VR esterna integrata, facile da calibrare a 94 dB con il cacciavite. Taratura tramite calibratore acustico esterno (a richiesta)
- Peso: 489 g / 1,08 LB
- Dimensioni: 245 x 68 x 45 mm
- Accessori inclusi: manuale d'uso, valigetta rigida di trasporto, CA-06
- Accessori opzionali: Calibratore del livello sonoro (94 dB)  
Cuffia antiventto  
SD card (2 GB)  
Cavo USB, USB-01  
Software di acquisizione dati, SW-U801-WIN

**CARACTERÍSTICAS TÉCNICAS**

Frecuencia y ponderación temporal Clase 1  
Las redes son compatibles con las normas IEC61672, ISO-9001, CE, IEC1010  
Cabeza 0.5" de micrófono  
Función de memoria para memorizar el valor Max y Min.  
Funcion de "Pico" y "Mantenimiento Pico"  
Innovación y operatividad fácil, el ordenador no necesita de un software adicional, después de ejecutar el registro de datos, simplemente quite la tarjeta SD del medidor y la conecte al ordenador, se pueden descargar directamente todos los valores de medición con la información del tiempo (Año /mes /día /hora /minuto /segundo) en Excel, entonces el usuario puede procesar en datos o hacer un análisis gráfico por sí mismo

- Rango de medición: 30 - 130 dB
- Resolución: 0,1 dB
- Función: dB (A & C ponderación de frecuencia y tiempo (rápido, lento) Retención de pico, Retención de datos, Registro (Máx, Min.)
- Calibración VR: calibración externa en VR ya incluida, fácil calibración del nivel en 94 dB por destornillador. Calibrado mediante calibrador de sonido externo (opcional)
- Peso: 489 g / 1,08 LB
- Dimensiones: 245 x 68 x 45 mm
- Accesorios incluidos: Manual de instrucciones estuche rígido CA-06
- Accesorios opcionales: Bola quitavientos de sonido Calibrador acústico (94 dB)  
Tarjeta SD (2GB)  
Cable USB, USB-01  
Software de adquisición de datos, SW-U801-WIN



SL 4001

Cod. 04.018.00

€ 375,00

**Fonometro classe 2 di precisione (IEC651)  
Sound level meter class 2 (IEC651)  
Fonómetro clase 2 (IEC 651)**

SL 4012

Cod. 04.018.05

€ 432,00

**Fonometro classe 2 con RS232  
Sound level meter class 2 with RS232  
Fonómetro clase 2 con RS232**

Cod. 04.018.06

€ 87,00

**Cavetto UPCB-2 per fonometro SL 4012, incl. software  
UPCB-2 cable for the sound level meter SL 4012, incl. Software  
Cable UPCB-2 para fonómetro SL 4012 con software incluido**

> **Contagiri**  
> *Revolutions counter*

Cod. 04.012.04

€ 1.150,00



>Contagiri per la lettura semplice e precisa dei giri e temperatura per motori benzina e diesel

>Revolutions counter for an easy and accurate reading of the revolutions on diesel and gasoline engines

**CARATTERISTICHE TECNICHE**

- > Display a colori LCD TFT 3,5" 320x240
- > Tastiera soft touch (Power On incluso)
- > Pacco batterie interno al Li-Ion
- > Carica batterie (8 ore di autonomia)

- Possibilità di rilevare numero di giri motore anche su moto
- Riesce ad isolare i principali segnali di disturbo, quindi ottimizza la lettura e la precisione dei valori
- Funzionamento con pacco batterie ricaricabili al Li-Ion con carica batterie in dotazione

- > Cavo base (A)
- > Carica batterie 12volt 2a (B)
- > Sonda di temperatura (C)
- > Cavo sensore accelerometrico (D)
- > Cavo alimentazione da batteria (E)
- > Cavo USB (F)
- > Manuale d'uso multilingue
- > Valigia con spugne sagomate

**TECHNICAL FEATURES**

- > LCD TFT color display 3,5" 320x240
- > Soft touch keypad (Power-On included)
- > Internal Li-Ion battery pack
- > Battery charger (8 hours of autonomy)

- It is possible to measure the number of revolutions also on motorbikes.
- It can single out the main interference signals, in so doing improving the measurement and precision of the observed values
- It works with a pack of rechargeable Li-Ion batteries and a supplied power cable

- > Power cable (A)
- > Battery charger 12v 2a (B)
- > Temperature probe (C)
- > Accelerometric sensor cable (D)
- > Battery power cable (E)
- > USB cable (F)
- > Multilingual manual
- > Case with shaped sponges

**Corredo standard / Standard equipment**



**Accessori a richiesta / Optional equipment**

€ 350,00

Cod. 04.012.05

> Dispositivo per la rilevazione dei giri e temperatura da presa OBD è anche in grado di fornire i codici readiness come previsto da alcune normative (es. Germania, Ungheria)

> Device for the measurement of the revolutions and the temperature from the OBD port, it is also possible to provide the readiness codes as requested by some regulations (ex. Germany, Hungary, etc.)



€ 350,00

Cod. 04.012.06

> Sonda fono accelerometrica per rilevazione giri moto  
> Phono-accelerometric probe for the detection of engine revolutions



€ 55,00

Cod. 04.012.07

> Adattatore contagiri per opacimetri e analizzatori gas di scarico  
> RPM counter's adapter for diesel and petrol analyzer





SIR 1000

Cod. 04.014.01

€ 105,00

**TERMOMETRO DIGITALE A RAGGI INFRAROSSI  
CON DOPPIO PUNTATORE LASER (-50/+1000°C - 58°/+1832°F)**

**DIGITAL INFRARED THERMOMETER  
WITH DOUBLE LASER POINTER (-50/+1000°C - 58°/+1832°F)**

**THERMOMÈTRE DIGITAL À RAYONS INFRAROUGE  
AVEC DOUBLE POINTEUR LASER (-50/+1000°C - 58°/+1832°F)**

**INFRAROTSRALENDIGITALTHERMOMETER  
MIT DOPPEL-LASERSENSOR (-50/+1000°C - 58°/+1832°F)**

**TERMÓMETRO DIGITAL DE RAYOS INFRARROJOS  
CON DOBLE APUNTADOR LÁSER (-50/+1000°C - 58°/+1832°F)**

APPLICAZIONI	USE	APPLICATION	ANWENDUNGSBEREICHE	USOS
Automotive: collettori di scarico; marmite catalitiche; radiatori; motori marini. Industriali: forni; compressori; motori diesel; impianti industriali in genere; cabine di verniciatura; ecc.	Automotive: discharge manifolds; catalytic silencers; radiators; marine motors. Industrial: furnaces; compressors; diesel engines; general industrial plants; spray booths; ecc.	Auto motive: collecteur d'échappe-ment; marmites catalyque; radiateur; moteur marin. Industriel: four, compresseur, moteurs diesel; systèmes industriel en général; cabine de vernissage.	Automobilbereich: Auspuffsammler; Katalysator-Auspufftöpfe; Kühler; Bootsmotore Industriebereich: Öfen; Kompressoren; allgemeine; Diesel-motore; Industrieanlagen; Lackierkabien, usw.	Automoción: colectores de descarga; catalizadores; radiadores; motores marinos. Industriales: hornos, compresores; motores diesel; instalaciones industriales, cabinas de pintura; ecc.
CARATTERISTICHE TECNICHE	TECHNICAL FEATURES	CARACTÉRISTIQUES TECHNIQUES	TECHNISCHE EIGENSCHAFTEN	CARACTERÍSTICAS TÉCNICAS
Misura della temperatura senza contatto Spegnimento automatico Grado di emissività: regolabile da 0,3 a 0,99 Rapporto distanza-dimensioni: 12:1 Doppio puntatore laser Data hold	Non-contact temperature measurement Operation Lock function Emissivity adjustable from 0.3 to 0.99 Dimension-distance ratio: 12:1 Double pointer laser Data hold	Rilevazione della temperatura sans contact L'appareil s'éteint automatiquement Grade d'émissivité: on le peut régler de 0.3 à 0.99 Dimension-distance ratio: 12:1 Double laser pointer Data hold	Temperaturmessung ohne Kontakt Automatisches Ausschalten Strahlungsvermögen: regulierbar von 0,3 bis 0,99 Verhältnis Abstand-Abmessung: 12:1 Doppel-Laserpointer Data hold	Medición de la temperatura sin contacto Apagado automático Grado de emisión: regulable de 0,3 a 0,99 Relación distancia-dimensiones: 12:1 Doble apuntador laser Data hold

Cod. 04.013.05

€ 39,80

**Termometro digitale a raggi infrarossi  
con puntatore laser -32°/+380°**

**Digital infrared thermometer  
with laser pointer -32°/+380°**

**Thermomètre digital infrarouge  
avec pointeur laser -32°/+380°**

**Infrarot-Digital-Thermometer Laser Point  
-32°/+380°**

**Termometro de rayos infrarrojos  
con puntador laser -32°/+380°**



HOT!

Cod. 04.052.00

€ 15,00

Art. PT201

**ERMOMETRO A PENNA -50°/+150°C**

ern thermometer -50°/+150°C

hermomètre à stylo -50°/+150°C

tiftthermometer -50°/+150°C

ermómetro tipo bolígrafo -50°/+150°C





**NEW!  
2018**

**Cod. 04.014.02**

Prezzo a richiesta  
Price on request  
Precio bajo pedido

**TERMO CAMERA A RAGGI INFRAROSSI  
INFRARED THERMAL IMAGING CAMERA  
CÁMARA DE IMÁGENES TÉRMICAS INFRARROJOS**



Campi di utilizzo • Fields of use • Campos de uso



Car engine maintenance  
Manutenzione del motore dell'automobile  
Car engine maintenance  
Mantenimiento del motor del coche



Air conditioning maintenance  
Manutenzione dell'impianto aria condizionata  
Air conditioning maintenance  
Mantenimiento del sistema de aire acondicionado



Transformer line maintenance  
Manutenzione della linea del trasformatore  
Transformer line maintenance  
Mantenimiento de la línea del transformador

**DATI TECNICI:**

- Display: 2.4"
- Risoluzione di immagine: 0.3 mega pixel
- Sensibilità termica: 0.5°C
- Range di temperatura: -20°/+300°C
- Memorizzazione immagini: scheda SD (4G)
- Tipo di batteria: 4\*1.5 V AA (non incluse)
- Tempo di spegnimento automatico: 12 minuti
- Dimensioni: 212x90x62mm
- Peso: 231 gr
- Dimensioni confezione: 270x190x110mm

**TECHNICAL FEATURES:**

- Display: 2.4"
- Image resolution: 0.3 mega pixels
- Thermal sensitivity: 0.5°C
- Temperature range: -20°/+300°C
- Image storage: SD card (4G)
- Battery type: 4\*1.5V AA (not included)
- Automatic switch-off time: 12 minutes
- Dimensions: 212x90x62mm
- Weight: 231 gr
- Package size: 270x190x110mm

**DATOS TÉCNICOS:**

- Pantalla: 2.4"
- Resolución de la imagen: 0.3 megapíxeles
- Sensibilidad térmica: 0.5°C
- Rango de temperatura: -20°/+300°C
- Almacenamiento de imágenes: tarjeta SD (4G)
- Tipo de batería: 4\*1.5V AA (no incluidas)
- Tiempo de apagado automático: 12 minutos
- Dimensiones: 212x90x62 mm
- Peso: 231 gr
- Tamaño del paquete: 270x190x110mm



**Cod. 05.036.00**

**€ 59,00**

**TESTER LIQUIDO FRENI  
BRAKE FLUID TESTER  
PROBADOR LÍQUIDO FRENOS**

- |  |                                      |   |
|--|--------------------------------------|---|
| • Test facile e rapido del liquido dei freni | • Easy and quick test of brake fluid | • Prueba Fácil y rápida del líquido de frenos |
| • Dot3 - Dot4 - Dot5.1                       | • Dot3 - Dot4 - Dot5.1               | • Dot3 - Dot4 - Dot5.1                        |
| • Affidabile e dal prezzo contenuto          | • Low cost and reliable              | • De bajo costo y fiable                      |

**Caratteristiche tecniche**

1. Antiurto
2. Compatibile con sonde a termocoppia di tipo K
3. Range: -50°/+1350 °C
4. Completo di custodia, batteria, istruzioni e 2 sonde a filo

**A richiesta sonda per: aria 04.052.02  
contatto 04.052.03**

**Technical features**

1. Shock-resistant
2. Compatible with K-type thermocouple probe
3. Range: -50°/+1350 °C
4. With case, battery, instruction manual and 2 wire-type probes included

**On request probe for: air 04.052.02  
contact 04.052.03**

**Caractéristiques techniques**

1. Antichoc
2. Compatible avec sondes à thermocouple de type K
3. Plage : -50°/+1350 °C
4. Equipé de : étui, batterie, instructions et 2 sondes à fil

**Sur demande sonde pour: aire 04.052.02  
contact 04.052.03**

**Technische Eigenschaften**

1. Stoßfest
2. Kompatibel mit Thermoelementen Typ K
3. Bereich -50°/+1350 °C
4. Komplett mit Etui, Batterie, Anleitungen und 2 Hitzdrahtsonden

**Auf Anfrage Sonde für: luft 04.052.03  
kontakt 04.052.02**

**Características técnicas**

1. Antichocho
2. Compatible con sonda termopar de tipo K
3. Intervalo: -50°/+1350 °C
4. Completo con estuche, batería, instrucciones y 2 sondas de hilo

**Bajo pedido sonda para: aire 04.052.02  
contacto 04.052.03**



Cod. 04.052.05

€ 75,00

**Termometro digitale differenziale  
(per refrigerazione e condizionamento)**

**Digital differential thermometer  
(for refrigeration and air conditioning)**

**Thermomètre numérique différentiel  
(pour réfrigération et conditionnement)**

**Digitales Differential-Thermometer  
(zum Kühlen und Klimatisieren)**

**Termómetro digital diferencial  
(para refrigeración y aire acondicionado)**

Cod. 04.052.02

€ 25,00

Cod. 04.052.03

€ 30,00

Cod. 04.052.04

€ 33,00



Pinza per tubi con termocoppia per misurazione temperatura  
Pipe wrench with thermocouple for temperature measurement  
Llave para tubos con termopar para mediciones de temperatura  
-50/+200°C

Cod. 04.020.00

€ 102,00



**ANEMOMETRO PORTATILE**

con sensore temperatura. Idoneo per linee revisione.

**PORTABLE ANEMOMETER**

with temperature sensor. Suitable for revision lines

**ANÉMOMÈTRE PORTABLE**

avec senseur température. Idéal pour révisions

**TRAGBARER ANEMOMETER**

mit Temperatursensor. Geeignet für Revisionslinien

**ANÉMOMETRO MÓVIL**

con sensor temperatura. Apto para las líneas de revisión

Cod. 01.000.231

€ 102,00

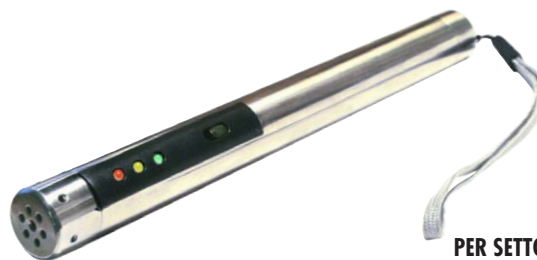

**CERCAFUGHE PER GAS INFIAMMABILI  
(METANO, PROPANO E BUTANO)  
PER SETTORE AUTOMOTIVE E INDUSTRIALE**

**LEAK DETECTOR FOR FLAMMABLE GASES  
(NATURAL GAS, PROPANE AND BUTANE) FOR THE AUTOMOTIVE AND INDUSTRIAL FIELD**

**DETECTOR DE FUGAS PARA GASES INFLAMABLES  
(GAS NATURAL, PROPANO Y BUTANO) PARA EL SECTOR AUTOMOTRIZ E INDUSTRIAL**

**CARATTERISTICHE TECNICHE**

Gamma di rilevazione 0-100% L.E.L. (Lower Explosive Level)  
2 livelli di intervento:  
50%±10% Led Rosso acceso  
20±5-50±10% Led Giallo acceso  
Tempo di risposta: <5 secondi  
Alimentazione: 2 batterie alcaline (include)

**TECHNICAL FEATURES**

Detection range 0-100% L.E.L. (Lower Explosive Level)  
2 levels of intervention:  
50%±10% Red LED lit  
20±5 - 50±10% Yellow LED lit  
Response time: <5 seconds  
Power supply: 2 alkaline batteries (included)

**CARACTERÍSTICAS TÉCNICAS**

Rango de detección 0-100% L.E.L. (Lower Explosive Level)  
2 niveles de intervención:  
50%±10% LED rojo encendido  
20±5 - 50±10% LED amarillo encendido  
Tiempo de respuesta: <5 segundos  
Alimentación: 2 pilas alcalinas (incluidas)

“TRINO”

Cod. 04.051.00

€ 63,00

**REFRATTOMETRO MULTIFUNZIONI  
MULTIFUNCTION REFRACTOMETER  
RÉFRACTOMÈTRE MULTIFONCTIONS  
MULTIFUNKTIONALE REFRAKTOMETER  
REFRACTÓMETRO MULTIFUNCIÓN**

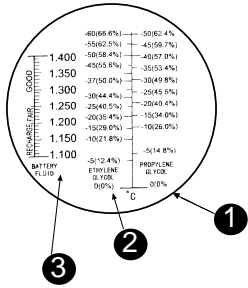

Uno strumento professionale per il controllo di:

- densità dell'acido della batteria
- punto di congelamento del liquido refrigerante del motore
- punto di congelamento del liquido lavavetri.

1

Liquido Lavavetri  
Freezing point of windscreen liquid  
Liquide nettoyage cristaux  
Reinigungslösung für Scheibenwaschanlage  
Líquido lavaparbrisas

2

Liquido Antigelo  
Antifreezing liquid  
Liquide antigel  
Frostschutzmittel  
Líquido anticongelante

3

Acido Batteria  
Battery acid  
Acide des batteries  
Batteriesäure  
Ácido de las baterías

A professional instrument to test:

- Density of acid batteries
- Freezing point of windscreen liquid
- Freezing point of refrigerant liquid of motor

Un instrument professionnel pour le control de:

- Densité de l'acide des batteries
- Point de givrage du liquide dans le moteur
- Point de givrage du liquide nettoyage des cristaux

Ein Profi-Instrument zur Kontrolle von

- Säuredichte von Batterien
- Gefrierpunkt des Kühlmittels des Motors
- Gefrierpunkt der Reinigungslösung in der Scheibenwaschanlage.

Un instrumento profesional para controlar:

- densidad del ácido de la batería
- punto de congelación del líquido refrigerante del motor
- punto de congelación del líquido lavaparbrisas

Cod. 04.051.01

€ 63,00

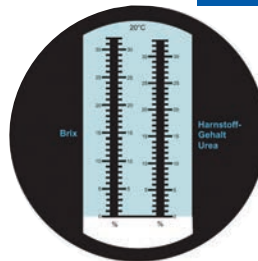

**REFRATTOMETRO PER UREA  
REFRACTOMETER FOR UREA  
REFRACTOMETRE POUR UREE  
REFRAKTOMETER FÜR UREA  
REFRACTÓMETRO PARA UREA**

Permette di rilevare la concentrazione dell'urea nei serbatoi di autocarri dotati di dispositivo antinquinamento (AD BLUE).  
2 scale 0-32%  
Brix graduation 0,2%,  
0-33% urea 0,2%  
Compensazione automatica della temperatura

It enables to assess the urea concentration in the tanks of the trucks equipped with an anti-pollution device (AD BLUE).  
2 scales 0-32%  
Brix graduation 0,2%,  
0-33% urea 0,2%  
Automatic compensation of the temperature

Il peut relever la concentration d'urée dans le réservoir des camions dotés de dispositif antipollution (AD BLUE).  
2 échelles 0-32%  
Brix graduation 0,2%,  
0-33% urée 0,2%  
Compensation automatique de la température

Ermöglicht die Ermittlung der Urea Konzentration in LKW Tanks mit Schadstoffschutvorrichtung (AD BLUE).  
2 scale 0-32%  
Brix graduation 0,2%,  
0-33% urea 0,2%  
Automatischer temperaturbereich

Permite detectar la concentración de urea en los tanques de los camiones equipado con un dispositivo anticontaminación (AD BLUE).  
2 escalas 0-32%  
Brix graduation 0,2%,  
0-33% urea 0,2%  
Compensación automática de la temperatura

Cod. 04.051.02

€ 370,00

**REFRATTOMETRO DIGITALE PER AD BLUE (UREA)  
DIGITAL REFRACTOMETER FOR AD BLUE (UREA)  
REFRACTOMETRE DIGITAL POUR AD BLUE (UREA)  
DIGITALES REFRAKTOMETER FÜR AD BLUE (UREA)  
REFRACTOMETRO DIGITAL PARA AD BLUE (UREA)**

- misura gradi brix
- misura temperatura (°C/F)
- zero setting
- auto power off

- measure of brix graduation
- temperature measure (°C/F)
- zero setting
- auto power off
- mesure degrés brix
- mesure température (°C/F)
- zéro tage
- éteignement automatique
- Vermessung der Brix-Graduierung
- Temperaturvermessung (°C/F)
- Null-Einstellung
- autom. Stromabschaltung
- medición grados brix
- medición temperatura
- ajuste cero
- autoapagamiento

Foto indicativa / Indicative picture





**MARCO TOOLS**  
BY SPIN

è un marchio distribuito da SPIN srl,  
produttore di autoattrezzature per le  
officine dal 1979 a Rimini

is a trade mark distributed by SPIN srl,  
manufacturer of garage equipment since  
the 1979 in Rimini - Italy

est une marque distribuée par la société  
SPIN srl, producteur d'équipement de  
garage du 1979 à Rimini - Italie

ist eine Vertriebsmarke der Firma SPIN srl,  
Hersteller von der Werkstatteinrichtung seit  
1979 in Rimini, Italien

es una marca distribuida por SPIN srl,  
fabricantes desde 1979 de equipamientos  
para talleres en Rimini, Italia

**MARCO**  
**TOOLS**  
BY SPIN

# Catalogo Generale General Catalogue 2018

**SPIN s.r.l.**

Via Casalecchio 35/G  
47924 Rimini (RN) Italy  
Tel. +39 0541.730777  
Fax +39 0541.731315  
e-mail: [info@spinsrl.it](mailto:info@spinsrl.it)  
[www.spinsrl.it](http://www.spinsrl.it)

**COMPANY WITH  
QUALITY SYSTEM  
CERTIFIED BY DNV GL  
= ISO 9001 =**

# Catalogo Generale General Catalogue

