



Ravaglioli

COMPANY WITH
QUALITY SYSTEM
CERTIFIED BY DNV GL
= ISO 9001 =

SOLLEVATORI ELETTROMECCANICI A 4 COLONNE 

ELECTRO-MECHANICAL 4 POST LIFTS 

ELEKTROMECHANISCHE 4-SÄULEN-HEBEBÜHNEN 

RAV

440NE

440E

442NE

442E

175E

118N



SINCE 1958





PERFETTAMENTE ORIZZONTALE

PERFECT LEVEL

PERFEKTE HÖHE

I motori sono collegati tra di loro mediante barra di trasmissione e scatole di rinvio con ingranaggi a bagno d'olio.

È così garantita una uguale ripartizione del carico sui motori e quindi un sollevamento perfettamente orizzontale delle pedane indipendentemente dalla posizione del carico sulle stesse. Una sola regolazione si effettua al momento dell'installazione e mai durante l'uso grazie all'assenza di organi cedevoli od allungabili come funi e catene portanti.

The motors are inter-connected mechanically by line shafting and bevel gear boxes in oil bath to ensure the perfect level of the platforms and balanced load on motors regardless of vehicle position. Only one adjustment is made during the installation, never during operation as there are no parts subject to yielding or lengthening such as cables and load bearing chains.

Die Motoren sind untereinander durch Wellentrieb und Kegelradgetriebe im Ölbad verbunden, um eine perfekte Höhe der Fahrschienen und eine ausgewogene Stromaufnahme bei jeder Lastbedingung zu erhalten. Nur eine einzige Regulierung ist bei der Einstellung nötig und nicht mehr während des Gebrauches, weil keine verlängerbaren und nachgebenden Teile, wie Kabel und Tragketten, vorhanden sind.

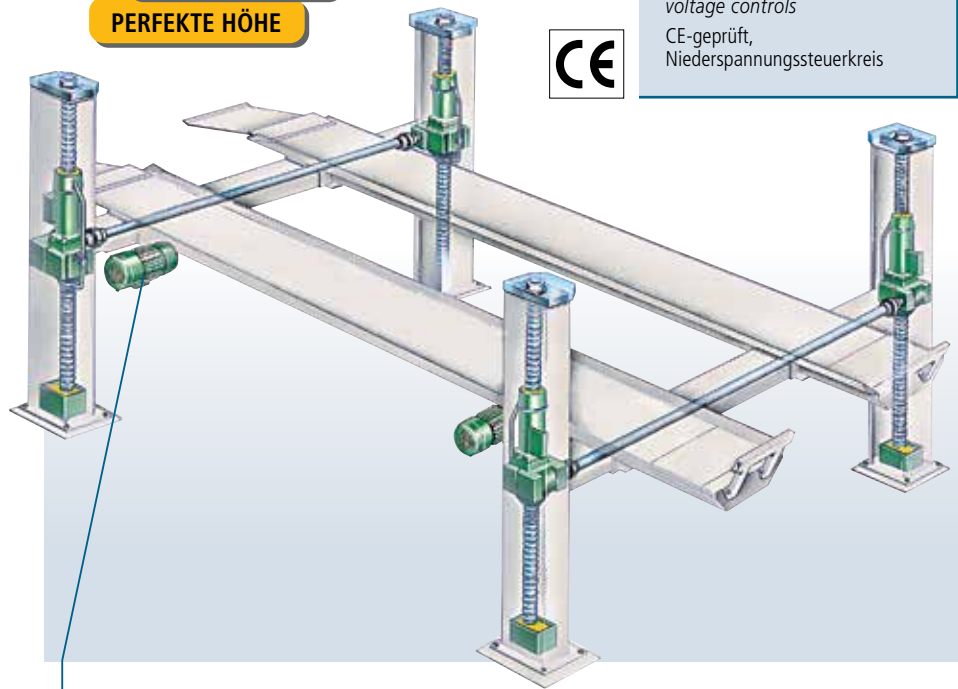

Ponte omologato CE, comandi in bassa tensione

CE approved lift with low voltage controls

CE-geprüft, Niederspannungssteuerkreis

Motori protetti da sonda termica per evitare danni in caso di sovraccarico o mancanza di fase.

Motor protection by thermal relay is provided to prevent burning out in case of overloading or lack of one phase.

Die Motoren sind mit Überlastungsschutz ausgerüstet, die die elektrische Anlage bei Ausfall einer Phase oder Überlastungen abschaltet.



KP440NE - KP440E

Due viti di sollevamento in ogni colonna

Two lifting screws in each column

Zwei Spindeln in jeder Säule

SICUREZZA TOTALE

TOTAL SAFETY

ABSOLUTE SICHERHEIT

Gruppo chiocciola portante e controchiocciola di sicurezza.

Main and safety nut assembly.

Trag- und Sicherheitsmutter-Einheit.

Fine corsa meccanico di sicurezza.

Mechanical safety stop.

Mechanischer Sicherheitsanschlag.

La lubrificazione delle viti di sollevamento è automatica mediante una pompa, presente in ogni colonna, che manda olio sopra la chiocciola portante e ne garantisce così una efficace lubrificazione durante il movimento.

Automatic lubrication of main and safety nuts and spindles is achieved by a plunger pump, one in each column, which ensures positive lubrication every time the lift is raised thus ensuring long life and smooth running.

Die Schmierung der Spindeln erfolgt automatisch durch vier Pumpen, eine in jeder Säule, die bei jedem Hub, Öl auf die Mutter spritzt.

Fine corsa elettrico superiore ed inferiore

Upper and lower limit switches.

Oberer und unterer Endschalter.

Micro controllo usura chiocciola.

Safety micro-switch in case of main-nut failure.

Sicherheitsschalter bei Abnutzung der Tragmutter.

Un dispositivo elettrico di sicurezza arresta il ponte qualora durante la discesa si trovasse oggetti estranei sotto le parti mobili.

A safety switch automatically stops motion should the lift encounter a solid obstacle during lowering.

Eine elektrische Sicherheitsvorrichtung unterbricht das Senken, falls ein Hindernis unter den beweglichen Teilen vorhanden ist.

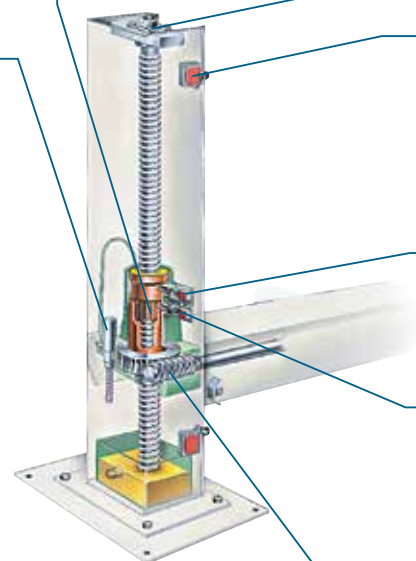

Scatola di rinvio con ingranaggi a bagno d'olio.

Bevel gears in oil bath.

Kegelradgetriebe im Ölbad.



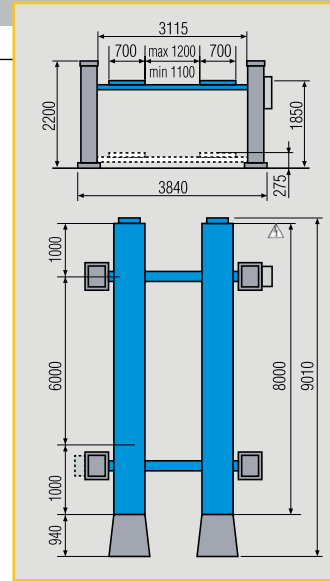

KP440NE / 24T
KP440E / 20T
KP442NE / 14T
KP442E / 12T

Sollevatori con lunghezza delle pedane e portate ideali per il sollevamento di autobus e autocarri.

The platform length and the capacity of these lifts make them ideal for busses and trucks.

Hebebühnen mit idealer Länge der Fahrschienen und Tragkraft für das Hochheben von Autobussen und LKW's.

DATI TECNICI	TECHNICAL DATA	TECHNISCHE DATEN		KP440NE	KP440E	KP442NE	KP442E
Portata	Capacity	Tragfähigkeit	kg	24000	20000	14000	12000
Motori trifase	Three-phase motors	Drehstrommotor	kW	4 x 4	4 x 4	4 x 2	4 x 2
Peso	Weight	Gewicht	kg	4200	4170	3110	3070
Pedane lunghezza	Platforms length	Fahrschienen-Länge	mm	8000	8000	8000	8000

PEDANE A SBALZO

EXTENDED PLATFORMS

ÜBERSTEHENDEN FAHRSCHIENEN



Massima praticità di lavoro grazie al particolare concetto delle pedane a sbalzo, uniche nel loro genere, che lasciano spazio libero facilitando il montaggio di qualsiasi particolare compreso il motore.

Maximum access to the vehicle thanks to the special concept of extended platforms, unique feature of the Ravaglioli range of commercial lifts. Space is freely available to fit any part, including the engine.

Sehr praktische Arbeitsweise dank der überstehenden Fahrschienen. Ideal zum Aus- und Einbau von LKW-Motoren, Getrieben und Einzelteilen geeignet.

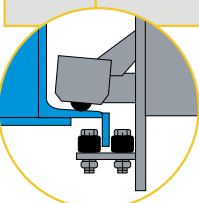
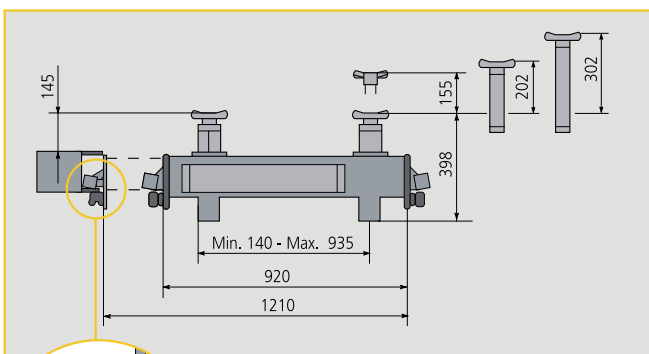

KP118N - KP118NP / 13,5T
Traversa idraulica/ pneumoidraulica a doppio pistone

Azionamento tramite pompa a mano o pompa pneumoidraulica (vers. NP)
Pressione alimentazione aria 6 ÷ 10 bar
Traslazione su sfere

Twin-piston hydraulic/air-hydraulic wheel-free jack

Operated by means of hand-pump or air-hydraulic pump (vers. NP)
Pneumatic feed pressure 6 ÷ 10 bar
Translation on ball-bearing

Hydraulischer / lufthydraulischer Achsheber mit Doppelkolben

Antrieb über Handpumpe oder lufthydraulische Pumpe (Ausf. NP)
Luftzuführungsdruck 6 ÷ 10 bar
Translation auf Kugeln



DUO-Ponti gemellati / DUO-Twin lifts DUO-Gekoppelte Hebebühnen

Per i modelli KP440NE-440E-442NE-442E esiste la possibilità di abbinare due ponti per farli funzionare:

- in modo sincronizzato, quindi con pedane sempre alla stessa altezza
- in modo singolo, quindi separatamente l'uno dall'altro con pedane ad altezze diverse.

Questa soluzione permette di sollevare veicoli particolarmente lunghi con il funzionamento gemellato, ma anche di mantenere la funzionalità separata per il servizio sui veicoli più comuni, garantendo quindi doppia redditività.

KP440NE-440E-442NE-442E can be twinned as follows:

- synchronised, therefore with the two lift platforms working at the same height;*
- in single mode, therefore with the two lifts working independently with platforms at different height.*

This solution enables the lifting of particularly long vehicles but also allows, in single mode, to make the lifts work separately to service the more common vehicles, therefore granting double return on the investment.

Für die Modelle KP440NE-440E-442NE-442E besteht die Möglichkeit diese miteinander zu koppeln, um diese:

- synchron zu schalten; d.h. die Fahrseilen immer auf der selben Höhe
- einzel zu schalten: d.h. von einander getrennt mit Fahrseilen auf verschiedenen Höhen.

Diese Lösung ermöglicht besonders lange Fahrzeuge hochzuheben, wenn die Bühnen miteinander gekoppelt sind. Wenn einzeln betätigt können die Bühnen getrennt arbeiten und garantieren somit eine doppelte Ertragsfähigkeit.

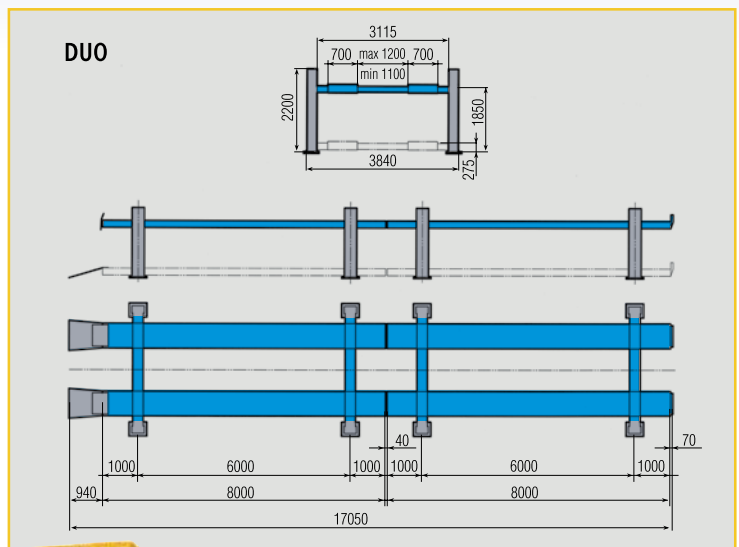

KP175E / 10T - 3740 mm

Sollevatori per carrelli elevatori
Lifts for fork lifts
Stapler-Hebebühnen

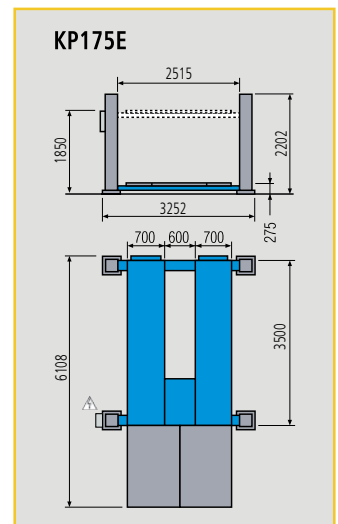

DATI TECNICI	TECHNICAL DATA	TECHNISCHE DATEN		KP175E
Portata	Capacity	Tragfähigkeit	kg	10000
Motori trifase	Three-phase motors	Drehstrommotor	kW	4 x 2
Peso	Weight	Gewicht	kg	2310

Ravaglioli



Ravaglioli S.p.A.

via 1° maggio 3
Fraz. Pontecchio M.
40037 Sasso Marconi (Bo) - Italia
Tel. +39 - 051 - 6781511
Fax +39 - 051 - 846349
rav@ravaglioli.com
www.ravaglioli.com

RAV France

4, Rue Longue Raie
ZAC de la Tremblaye
91220 Le Plessis Pâté
Tel. 01.60.86.88.16
Fax 01.60.86.82.04
rav@ravfrance.fr

Ravaglioli Deutschland

Kirchenpoint 22
85354 Freising
Tel. 08165-646956
Fax 08165-646958
info@ravaglioli.de

RAV Equipment UK LTD

Prince Albert House
20 King Street
Maidenhead, SL6 1DT
Tel. +39 - 0516781522
rav@ravaglioli.com

RAV en Belgique

Nederlandstalig
Tel. 0498-162016
Fax 016-781025
Zone Francophone
Tel. 0498-163016
Fax 078 055030

RAV Equipos España

Avenida Europa 17
Pol. Ind. de Constanti
Tarragona 43120
Tel. 977 524525
Fax 977 524532
ravequipos@ravaglioli.e.telefonica.net

