

# HIGH PERFORMANCE SUPER-AUTOMATIC TILT BACK TYRE CHANGER WITH DUAL ASSIST ARM

**DEMONTE-PNEUS SUPER-AUTOMATIQUE A HAUTE  
PERFORMANCE AVEC BRAS D'APPOINT  
A DOUBLE FONCTION**

## SX 234

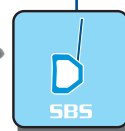
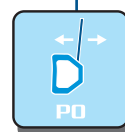
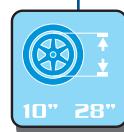
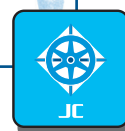

\* Version available upon request / Version disponible sur demande

# SX 234

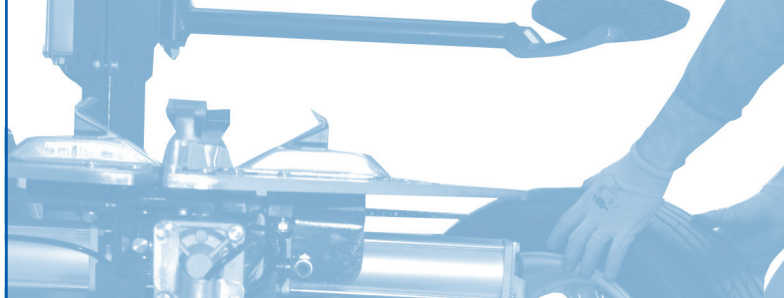

## STANDARD FEATURES - DONNEES TECHNIQUES

|  |   |
|--|---|
| Rim clamping from outside<br><i>Blocage jante de l'extérieur</i>               | 10" - 26"   |
| Rim clamping from inside<br><i>Blocage jante de l'intérieur</i>                | 12" - 28"   |
| Max. tyre diameter<br><i>Diamètre maxi. roue</i>                               | 1120 mm (44")   |
| Max. tyre width<br><i>Largeur maxi. roue</i>                                   | 406 mm (16")  |
| Bead breaker cylinder force at 10 Bar<br><i>Force vérin décolleur à 10 Bar</i> | 30800 N   |
| Operating pressure<br><i>Pression de service</i>                               | 10 Bar (145 Psi)                                      |
| Power supply<br><i>Alimentation</i>  | 400V - 3ph/2speed<br>220V - 1ph<br>220V - 1ph/2 speed |
| Motor power<br><i>Puissance moteur</i>   | 0,8 / 1,1 kW (3ph)                                    |
| Rotation speed<br><i>Vitesse de rotation</i>                                   | 7 - 14 rpm  |
| Pre-set tyre inflating pressure<br><i>Pression de gonflage maxi.</i>           | 3,5 Bar (50 Psi)                                      |
| Net weight<br><i>Poids net</i>   | 390 kg  |

**For high volume tyre shops, and tyre specialists, servicing racing, run flat and UHP tyres.**  
**Pour les ateliers gérant des volumes élevés et pour les spécialistes des pneus Racing, Run Flat et Uhp.**

## FUNCTIONS - CARACTERISTIQUES

Tilting tower, sliding horizontal arm with Ø 41 mm operating arm  
*Bras vertical basculant, bras horizontal coulissant avec bras porte outil hexagonal de Ø 41 mm*

Bead breaker double effect Cylinder Ø 200 mm  
*Vérin détalonneur de Ø 200 mm à double effet*

Reinforced Chassis and Tower  
*Châssis et bras vertical renforcés*

Tabletop thickness 12 mm w/POWER X four cylinders clamping system (Giuliano Patent)  
*Plateau centreur ayant une épaisseur de 12 mm avec système de blocage par 4 verins pneumatiques « POWER X » (brevet Giuliano)*

Fitting head designed for both standard and low profiled tyre applications  
*Tête de montage conçue pour les pneus standards ainsi que pour les pneus à profil rabaisé*

Double rotation speed by pedal  
*Double vitesse de rotation par pédale*

Tyre inflation by pedal (standard)  
*Dispositif de gonflage par pédale (standard)*

Patented SBS System for bead breaker shovel travel memory  
*Système SBS (SMART BLADE SYSTEM) breveté pour la mémorisation de la position du détalonneur*

Equipped with HP2 dual assist arm (standard) and storage box  
*Equipé standard du bras d'appoint avec double fonction HP2 et de boîte de rangement outils*

Suitable for Tubeless tyre bead seating system (optional)  
*Système de gonflage Tubeless GUN (en option)*

"Easy Access" extractable pedal box for quick service  
*Pédalier amovible et facilement accessible pour les opérations d'entretien rapide*

Adjustable bead breaker shovel angle  
*Réglage de l'angle de la pelle décolle-talon*

QuadraLock system for total stiff locking of horizontal and operating arm  
*Système « QuadraLock » pour la rigidité totale de blocage du bras horizontal et porte outil*

PO System, Giuliano patent, for granting no bead breaker shovel stuck into the rim during bead breaking operations  
*Dispositif « PO System » permettant d'éviter le coincage de la pelle décolle-talons dans la jante (brevet Giuliano) pendant le décollage du talon*

Robotic pipe for operating arm positioning/lock  
*Système robotisé pour le positionnement/blocage du bras opérateur*

Suitable for Wheel Lifter (optional)  
*Possibilité de montage de l'élévateur de roue (en option)*

## DIMENSIONS - DIMENSIONS

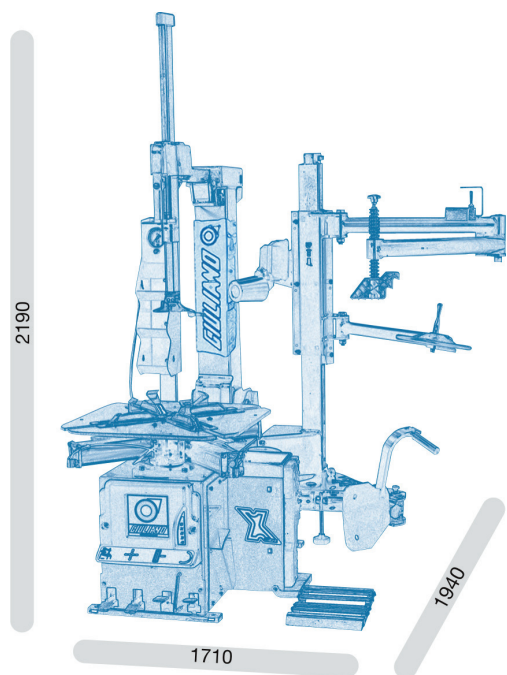

## STANDARD ACCESSORIES - ACCESSOIRES STANDARD



Profession : Passion

Giuliano Industrial S.p.A: Via Guerrieri, 6 - 42015 CORREGGIO (RE) ITALY  
Tel. +39 0522 731111 - Telefax +39 0522 633109 - E-mail: info@giuliano-automotive.com  
Internet: www.giuliano-automotive.com

Since 1976

